

Centrifugal Pump Performance Curves and Technical Information

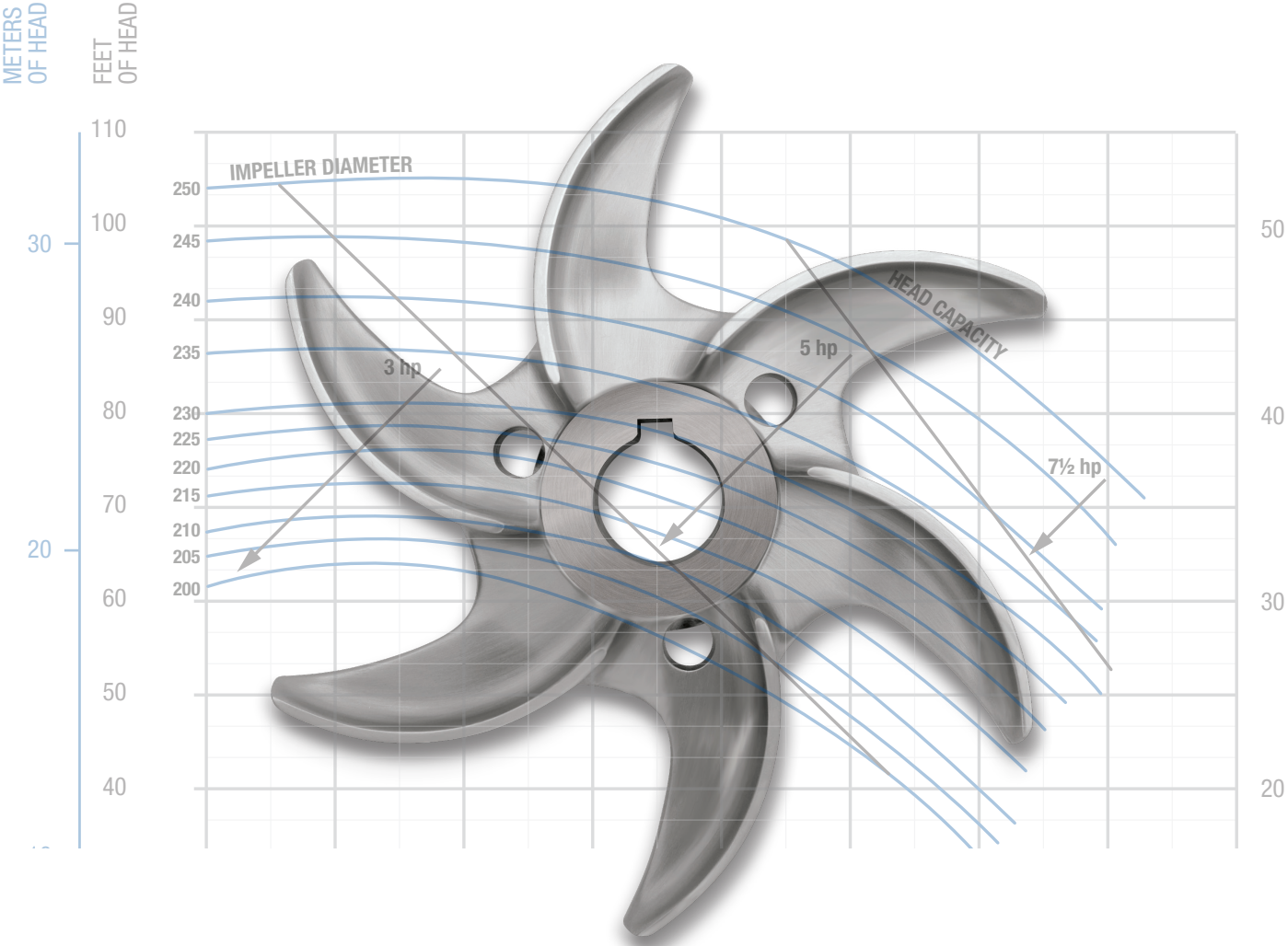

Table of Contents

| | |
|--|----|
| Introduction | 2 |
| Pump basics | 4 |
| Selecting a pump | 5 |
| Pump inquiries application data sheet | 7 |
| How to calculate required pressure | 8 |
| Determining net positive suction head (NPSH) | 8 |
| Specific gravity and viscosity chart..... | 9 |
| Conversion factors..... | 10 |
| Vapor pressure chart | 10 |
| Tubing friction loss chart..... | 11 |
| Fristam centrifugal pump options..... | 12 |
| Pharmaceutical options..... | 13 |
| Pump Performance Curves: 1750 RPM | |
| FP/FPX/FPR Composites (2) | 14 |
| 701 | 16 |
| 711 | 17 |
| 721 | 18 |
| 3521 | 19 |
| 731 | 20 |
| 3531 | 21 |
| 741 | 22 |
| 1741 | 23 |
| 3541 | 24 |
| 751 | 25 |
| 3451 | 26 |
| 3551 | 27 |
| 1051 | 28 |
| 1151 | 29 |
| 1161 (2) | 30 |
| 3001 | 32 |
| 4001 | 33 |
| 4001X..... | 34 |
| Pump Performance Curves: 3500 RPM | |
| FP/FPX/FPR Composites (2) | 36 |
| 702 | 38 |
| 712 | 39 |
| 722 | 40 |
| 3522 | 41 |
| 732 | 42 |
| 1732 | 43 |
| 3532 | 44 |
| 742 (2) | 45 |
| 1742 (2) | 47 |
| 3542 | 49 |
| 752 | 50 |
| 3452 | 51 |
| 3552 | 52 |
| 3552-4" | 53 |
| 3642 | 54 |
| 3652 | 55 |
| Dimensional Drawings | |
| FP Single Flange | 56 |
| FP Double Flange (2) | 57 |
| FPX Single Flange..... | 59 |
| FPX Double Flange | 60 |
| FPR Single Flange..... | 61 |
| FPR Double Flange (2)..... | 62 |

Fristam Pride

Fristam is a global manufacturer of sanitary centrifugal and positive displacement pumps, mixers and blenders respected for unmatched performance, reliability, and technical superiority.

Fristam manufactured its first pump in 1931. Today, Fristam equipment is used by many of the world's top dairy, beverage, brewing, bio-pharmaceutical, and food processing companies.

High Lifetime Value

The solid design, precise machining, and robust construction of a Fristam pump ensures efficiency and operational reliability. Fristam pumps simply run better and last longer.

Quality Control

Fristam Pumps USA designs, manufactures, and assembles its pumps in the United States. Each component is carefully checked from raw material through final assembly.

The result of this effort is a pump worthy of the valuable product your company produces. To achieve the highest level of quality, Fristam offers the most comprehensive testing and documentation packages in the sanitary pump industry.



**Designed, Manufactured &
Assembled in Middleton, WI**

Experience and Expertise

Over the past 100 years, Fristam has built its reputation with experience, attention to detail, and a willingness to adapt to changing needs. Fristam's strong applications engineering capabilities make it the most reliable source for straight, smart answers to process needs.

Fast Delivery, New Solutions

Manufacturing in the United States ensures Fristam customers receive prompt delivery, not lead times measured in months.

Additionally, if a new production challenge arises, Fristam is responsive and able to develop new solutions quickly.

Dedicated Support

Fristam's dedication and quality service do not end with your initial purchase. An international network of manufacturing facilities, sales offices and distribution supports Fristam's commitment to customer satisfaction.

Why Customers Choose Fristam

"simply better pumps"

"reliable, dependable"

"high standard for sanitization and performance"

"knowledgeable people who help solve problems"

Pump Basics: Background Information

Pump Series - FP, FPX, or FPR

The FP, FPX, and FPR Series pumps are manufactured of 316L stainless steel and have the same pump head. The FP incorporates a heavy-duty pedestal flange between the motor and pump head. The FPX is a motor mounted pump used for standard duties. The FPR has a front-loading seal for easy changeout and may be used in place of either the FP or FPX. Double seals are only available in the FP and FPR. The FP is used for vacuum withdrawal, high temperature, high viscosity, aseptic processes and other demanding applications.

Pump Model/Housing Size

Fristam offers both volute and non-volute (circular) housings in many sizes to best match different process needs. The 700 and 1700 series pumps are non-volute and designed for lower capacities. Their shorter, steeper curves provide better efficiencies on low flows and superior accuracy when used with control devices. The 1050, 1150, 3400 and 3500 series pumps are volute high capacity pumps. Their long, flat curves provide greater capacity and an ability to provide steady discharge pressure over a wide flow range.

Speed

Pumps are sized using two standard speeds, 1750 and 3500 RPM. Speed selection is determined when selecting a housing. The last digit of the Fristam model number indicates the speed. All models ending in 1 are 1750 RPM. All models ending in 2 are 3500 RPM.

Efficiency

The efficiency of centrifugal pumps varies over the individual curve. The most efficient point of two curves is illustrated in Figure 1. When sizing, it is helpful to select a pump whose curve puts the duty point as close to this bend in the curve as possible.

Impeller Size

Within a given housing, the impeller diameter will determine the flow and pressure produced. Pressure results from the velocity achieved within the pump. The highest velocity occurs at the tip of the impeller and is directly proportional to the square of the impeller diameter. At a given speed, a larger diameter impeller will impart more velocity and produce more pressure.

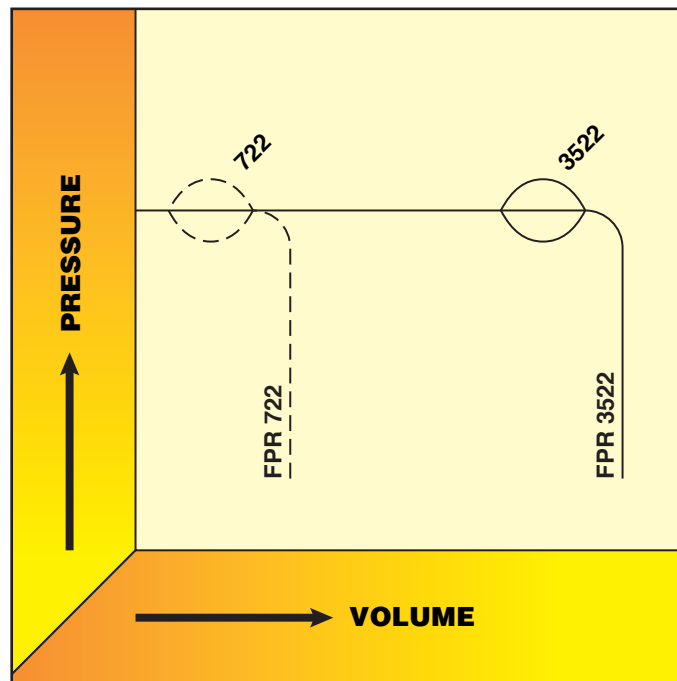

Figure 1

Horsepower

Horsepower must be matched to a given duty or duties. The requirements are determined by individual curves. Enough horsepower must be supplied to handle the most demanding duty, often the duty requiring the most flow, pressure or the pumping of the heaviest product.

Net Positive Suction Head (NPSH)

Product must be forced into a centrifugal pump for it to function properly. This force is called NPSH. Your process must have sufficient NPSH available to meet or exceed the NPSH required.

Seals

Fristam offers a wide selection of seals. Most processes require a standard single seal of chrome oxide coated stainless steel on carbon. More difficult applications will require harder seal materials such as silicon carbide. Double seals are used when a flush is required, where abrasion or stickiness is a problem, for vacuum withdrawal or if a sterile barrier is required between the process and atmosphere.

Selecting a Fristam Pump: A Step by Step Guide

Special Considerations

All curves are based on 70°F water. If your process involves products under vacuum, with high viscosity, high specific gravity, high temperatures, undissolved solids or entrained air there are special considerations which affect pump selection. In such cases, please consult Fristam Pumps or your local Fristam distributor.

Selecting a Pump Model From the Composite Curves

Composite curves appear at the beginnings of the low- and high-speed sections. To select the correct pump model from the composite curves, find the desired flow rate along the bottom scale and the desired pressure on the left-hand vertical scale. Find the point where the vertical line from the flow rate and a horizontal line from the pressure intersect. The curve immediately above this point will be most suitable.

Example

As an example, size a pump to pump 50 gallons per minute and generate 135 feet of head. In the composite shown in Figure 2, find the intersection point of 50 GPM on the bottom of the graph and 135 feet on the side. The pump curve directly above the duty point is the 722. In this example, model 742 (the next size larger) might also be considered. A quick review of the duty point on their individual curves reveals the 722 will be more efficient than the 742.

Considering Speed and Efficiency

If both pumps are the same speed, consider which will be more efficient based on the information discussed in Figure 1. If both a high and low speed pump can handle the duty, the high speed will generally be more economical, but the low speed model may have a lower NPSH requirement.

Choosing Impeller Size and Horsepower

Having chosen a pump model based on the first two steps, find the specific curve for the pump model chosen. To determine the impeller diameter and horsepower move vertically from the flow and horizontally from the pressure or head desired. Find the intersecting point.

The next higher curve indicates the correct impeller diameter. The diagonal line immediately to the right of the intersection identifies the motor horsepower required.

Figure 2

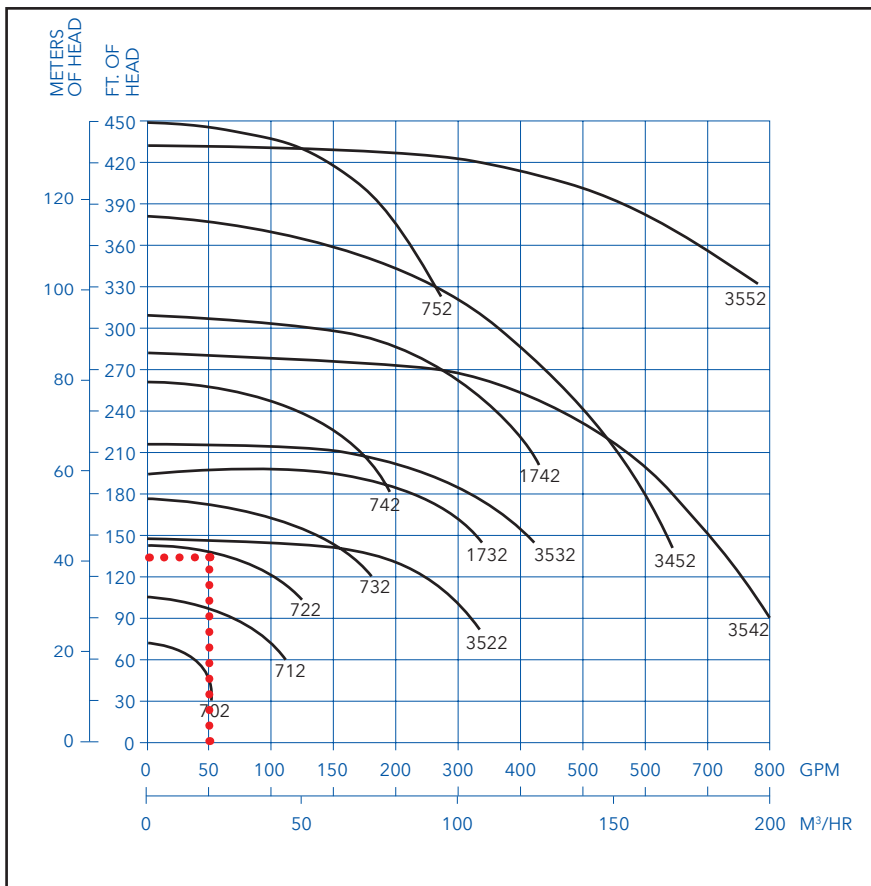

Example

Using our previous example of 50 gallons per minute and 135 feet of head, we can determine from Figure 3 that the impeller diameter should be 145 millimeters (5.7 inches). The motor required is 5 horsepower.

Checking NPSH (Net Positive Suction Head)

To assure there is sufficient product pressure at the inlet of the pump the suction conditions need to be checked. The NPSH required can be determined by finding the point on the individual pump curve where the vertical line from the desired flow rate intersects the NPSH curve. From this point, a horizontal line to the right will intersect the NPSH scale at the net positive suction head required.*

The procedure for determining the NPSH available is described in the “How To Calculate Required Pressure” section of this book. When the NPSH available is determined, it must meet or exceed the NPSH required for the pump to function properly. If the NPSH available is insufficient, a change to the inlet conditions, an enlarged inlet or another pump selection may be required.

Example

A 722 pumping 50 GPM against 135 feet of head will require 6 feet or more of NPSH. The installation must provide at least 6 feet of head.

Elastomers

Viton is the standard seal elastomer and BUNA is standard for the cover gasket. Other materials and combinations are available to meet your application or process needs.

Seal Selection: Single or Double

Many applications require only single seals. Double seals are recommended for applications involving:

- Abrasive products
- Sticky products
- Vacuum >14” Hg
- Temperature regulation

Seal Selection: Materials

Recommended seal material configurations:

- Simple transfer applications: FR-N-(K)*
 - Sticky applications: FR-C-(N)*
 - Pharmaceutical applications, chlorine, brine: C-C-(N)*
- * rotating seal, stationary seal, (flush/double seal)

N = Carbon

C = Silicon Carbide

FR = Chrome Oxide Coated Stainless Steel

K = Ceramic

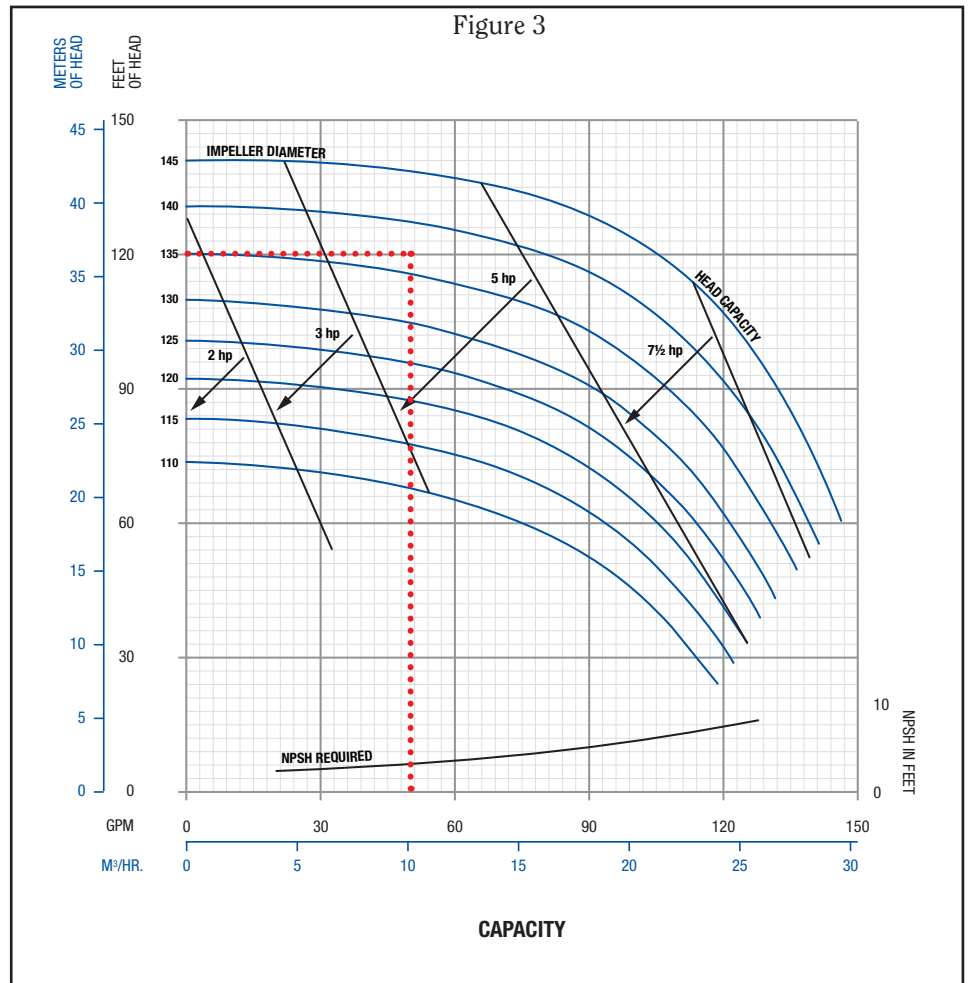

*Please note that the NPSH values shown are for full size impellers. Smaller impellers may require somewhat greater NPSH.

Pump Inquiry Application Data Sheet

The following information is required to properly process an inquiry:

Requested by _____ Date _____

Customer _____

Address _____

Telephone _____ Fax _____ Email _____

Description of product to be pumped _____

Temperature _____ Specific Gravity _____ or Density _____ lb./gal.

Viscosity _____ Centipoise (CPS) or other

Desired Flow Rate _____ GPM or lb./hr.

*Discharge Head _____ ft. or PSI

Suction Conditions

Is the pump withdrawing from a vacuum? _____ Yes _____ No

If so, how much? _____ in. Hg.

Is the product level on the inlet side of the pump above or below the center line of the pump inlet?

Above _____ Below _____ By how much? _____ in. or ft.

Tubing _____ in. Diameter _____ Length _____ No. of elbows _____ No. of tees

Tubing _____ in. Diameter _____ Length _____ No. of elbows _____ No. of tees

No. of size of valves in suction piping:

_____ No. _____ Size (in.)

_____ No. _____ Size (in.)

Other equipment in the suction piping _____

*If you do not know the desired discharge head, please provide the following:

Discharge Conditions

Is the final destination of the pump above or below the center line of the pump inlet?

Above _____ Below _____ By how much? _____ in. or ft.

Tubing _____ in. Diameter _____ Length _____ No. of elbows _____ No. of tees

Tubing _____ in. Diameter _____ Length _____ No. of elbows _____ No. of tees

Tubing _____ in. Diameter _____ Length _____ No. of elbows _____ No. of tees

No. and size of valves in discharge piping:

_____ No. _____ size (in.)

_____ No. _____ size (in.)

_____ No. _____ size (in.)

Other equipment and the drop or pressure requirement (PSI) in the discharge piping _____

How To Calculate Required Pressure

Example:

Find the head under these conditions: Pump is drawing from an open tank to discharge through a heat exchanger into an open tank that is 20 ft. above the pump. The supply is 8 ft. above the pump. 50 GPM flow is required.

Solution:

1. Height to be pumped is 20 ft. minus 8 ft. =12.0 ft.

2. Friction loss from pipe is
 (8 ft. + 10 ft. + 20 ft. + 299.2 ft. = 337.2 ft.)
 337.2 x .25 ft./ft. =84.3 ft.

3. Friction loss from 3 elbows is = 0.6 ft. = 0.6 ft.

4. *Heat Exchanger loss 2.31 times 16.5 PSI =38.1 ft.

The Total Head Loss is 135.0 ft.

*Heat Exchanger information supplied by manufacturer.

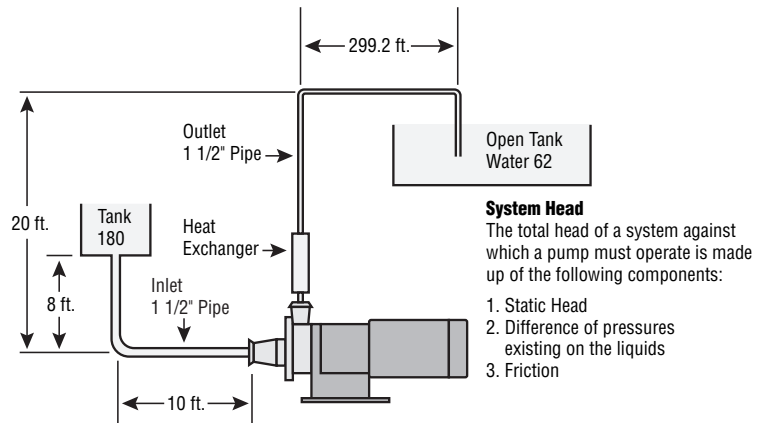

System Head
 The total head of a system against which a pump must operate is made up of the following components:
 1. Static Head
 2. Difference of pressures existing on the liquids
 3. Friction

Determining Net Positive Suction Head (NPSH)

Fristam pumps are well known for requiring less net positive suction head (NPSH) available than other sanitary centrifugal pumps. However, due to the hydraulic principles involved, some level of NPSH is still required in order for the pump to run efficiently and without cavitating.

The NPSH required for each Fristam pump model has been determined by careful testing. The results of these tests are illustrated by the NPSH curve under the performance curves for each pump model.

To determine the NPSH available, first add the physical height of the liquid above the centerline of the pump inlet to the pressure above the liquid (in an open tank this is atmospheric pressure). From this total, subtract the friction losses of the line and fittings on the suction side and the vapor pressure of the liquid at the operating temperature. The remainder is the NPSH available. This number must meet or exceed the NPSH required in order for the pump to function properly. As an example, figure the NPSH available and required to pump 50 GPM and generate 135 feet water column of pressure.

The pump model required is a 722 with a 145 mm impeller (see “Selecting a Fristam Pump”). From the actual pump curve or from the example in “Selecting a Fristam Pump,” we see that the NPSH required is 3 feet.

Assuming 10 feet of 1 1/2 inch line and one elbow in the suction line, 8 feet of height of liquid above the pump center line and pumping 180°F water from an open tank, we can compute the NPSH available.

NPSH available = Physical height of liquid + atmospheric pressure - friction losses - vapor pressure (see “Vapor Pressure Chart”).

$$\text{NPSH available} = 8 \text{ ft.} + 33.9 \text{ ft.} - 4.7\text{ft.} - 17.3 \text{ ft.} = 19.9 \text{ ft.}$$

Since the NPSH available of 19.9 feet is greater than the NPSH required 3 feet, the pump has sufficient NPSH available to run properly.

Specific Gravity and Viscosity for Various Liquids

| Product | SP. Gr. | Visc. (cps) | Temp °F | Condition |
|------------------------|--------------|-------------|---------|----------------------|
| Acetone | 0.80 | 1 | 70 | |
| Acid: | | | | |
| Acetic | 1.01 | 1 | 100 | 5% |
| Citric | 1.02 | 1 | 140 | 10% |
| Lactic | 1.10 | 1 | 140 | |
| Nitric | 1.02 | 18 | 70 | |
| Alcohol: | | | | |
| Ethyl | 0.82 | 1.4 | 70 | |
| Methyl | 0.79 | 0.6 | 70 | |
| Alum | 1.33 | 80 | 40 | 50% Conc. |
| Barbecue Sauce | 1.10 | 150 | 70 | 33° Brix |
| Beer | 1.02 | 1 | 40 | |
| Beverage Concentrate | 1.26 | 80 | 80 | |
| Blood | 1.00 | 5 | 20 | |
| Brine | 1.10 to 1.20 | 1 | 40 | Sodium Chloride 1.20 |
| Butter—Melted | 0.95 | 90 | 90 | |
| Buttermilk | 1.04 | 20 | 40 | |
| Carbon Tetrachloride | 1.59 | 1 | 70 | |
| Catsup | 1.15 | 100 | 60 | |
| Chocolate Bar Coating | 1.08 | 65 | 120 | |
| Cream | 0.99 | 20 | 40 | 40% Fat |
| Dye, Water Base | 1.10 | 10 | 70 | |
| Egg—Whole | 1.04 | 68 | 40 | |
| Egg Yolk | 1.12 | 400 | 68 | |
| | | 200 | 86 | |
| Ethylene Glycol | 1.10 | 18 | 70 | |
| Fat—Animal Melted | 0.90 | 43 | 110 | |
| Glaze—Donut | 1.22 | 55 | 120 | |
| Honey | 1.30 | 230 | 100 | 81.2° Brix |
| | | 1500 | 70 | |
| Ice Cream Mix | 1.15 | 300 | 40 | Varies |
| Ink, Printer's | 1.20 | 520 | 130 | |
| Juice—Single Strength: | | | | |
| Apple, Clear | 1.05 | 20 | 140 | |
| Cranberry | 1.03 | 10 | 140 | |
| Grape | 1.05 | 25 | 140 | |
| Orange | 1.05 | 20 | 140 | |
| Tomato | 1.03 | 180 | 140 | |
| Juice—Concentrate: | | | | |
| Apple | 1.36 | 600 | 50 | Thixotropic |
| Cranberry | 1.03 | 250 | 100 | Thixotropic |
| Grapefruit | | 1000 | 38 | Thixotropic |
| Orange | 1.32 | 5000 | 38 | Thixotropic |
| Liqueurs | 1.15 | 10 | 70 | |
| Margarine | 0.93 | 50 | 120 | |
| Milk—Whole | | 1.03 | 1 | 40% TS |
| Milk—Concentrated | 1.10 | 1000 | 50 | 40% TS |
| | 1.30 | 100 | 131 | 75% TS |
| Milk—Concentrated | 1.20 | 20 | 110 | 45% TS |
| Skim | 1.10 | 95 | 70 | 30% TS |
| Milk—Evaporated | 1.17 | 60 | 70 | 48% TS |
| Milk—Skim Condensed | 1.20 | 20 | 110 | 45% TS |

Detailed information is available on viscosity correction factors. Contact Fristam Pumps for details. The following viscosities may vary, depending upon products, formulas, and processes used by processors.

| Product | SP. Gr. | Visc. (cps) | Temp °F | Condition |
|------------------|---------|-------------|---------|--------------|
| Milk—Sweetened | 1.25 | 2000 | 50 | |
| Condensed | | 500 | 150 | |
| Milk of Magnesia | 1.08 | 200 | 70 | |
| Oils: | | | | |
| Butter | 0.90 | 40 | 70 | |
| Corn | 0.93 | 150 | 60 | |
| Frying | 0.90 | 10 | 400 | |
| Lard | 0.96 | 165 | 80 | |
| Mineral | 0.93 | 150 | 70 | |
| Olive | 0.92 | 110 | 60 | |
| Peanut | 0.92 | 100 | 60 | |
| Soybean | 0.93 | 95 | 60 | |
| Vegetable | 0.92 | 40 | 100 | |
| Paint Solvents | 0.90 | 10 | 70 | |
| Paper Coatings | 1.05 | 400 | 70 | 35% TS |
| Paraffin | 0.90 | 9 | 140 | |
| Pear Puree | 1.30 | 4000 | 160 | Thixotropic |
| Perfume | 0.95 | 1 | 70 | |
| Pie Filling | 1.20 | 200 | 140 | |
| Propylene Glycol | 1.02 | 20 | 30 | 50% |
| Sauce—Apple | | 2000 | 71 | |
| | | 800 | 190 | |
| Salad Dressing | 0.96 | 5000 | 75 | |
| Shampoo | 1.00 | 350 | 70 | |
| Sorbitol | 1.30 | 150 | 70 | 75% |
| Soup, Clear | 1.00 | 20 | 160 | |
| Spaghetti Sauce | 1.10 | 200 | 140 | |
| Syrups: | | | | |
| Corn | 1.39 | 240 | 180 | 40° Be |
| Dextrose | 1.35 | 280 | 180 | 77° Brix |
| HFCS 42 | 1.35 | 160 | 70 | 42% TS |
| HFCS 55 | 1.35 | 800 | 70 | 55% TS |
| Invert | 1.38 | 800 | 80 | 76° Brix |
| Maple | 1.37 | 600 | 68 | |
| Sugar | 1.33 | 220 | 80 | 68° Brix |
| Soft Drink | 1.26 | 80 | 80 | |
| Toulene | 0.87 | 1 | 70 | |
| Tomato Paste | 1.14 | 150 | 75 | 11% TS |
| | 1.14 | 100 | 180 | 11% TS |
| | 1.14 | 1500 | 200 | 17% TS |
| Varnish | 0.90 | 125 | 100 | |
| Vinegar | 1.01 | 1 | 70 | |
| Water | 1.00 | 1 | 70 | Includes WFI |
| Wax, Liquid | 1.00 | 75 | 70 | |
| Whey: | | | | |
| Acid/Sweet | 1.06 | 2 | 100 | |
| Condensed | 1.11 | 20 | 100 | 27% TS |
| | 1.20 | 800 | 40 | 40% TS |
| | 1.20 | 400 | 130 | 50% TS |
| | 1.20 | 550 | 65 | 50% TS |
| | 1.24 | 1500 | 65 | 60% TS |
| Sweetened | 1.20 | 900 | 55 | 50% TS |
| | 1.24 | 600 | 145 | 60% TS |
| Salt | 1.06 | 2 | 80 | |
| Wort | 1.05 | 100 | 150 | |
| Yeast—Brewer's | | | | |
| Fermenting | 1.10 | 150 | 40 | 20% TS |
| Slurry | 1.10 | 270 | 45 | 35% TS |
| Yogurt Mix | 1.03 | 20 | 40 | |

Conversion Factors

Length

| | |
|-------------|-------------------|
| Meters | x 3.281 = Feet |
| Centimeters | x 0.394 = Inches |
| Millimeters | x 0.0394 = Inches |

Mass

| | |
|---------------------|---------------------|
| Kilograms | x 2.2 = Lbs. |
| Gallons Of Water | x 8.34 = Lbs. |
| Cubic Feet of Water | x 62.4 = Lbs. |
| Pounds | x 0.454 = Kilograms |

Volume

| | |
|---------------------------|-----------------------|
| Liter | x 0.264 = Gallon |
| Cubic Feet | x 7.48 = Gallon |
| Lbs. Of Water | x 0.119 = Gallon |
| Imperial Gallon (British) | x 1.2 = Gallon (U.S.) |
| U.S. Gallon | x 3.785 = Liter |

Pressure

| | |
|--------------------------|---------------|
| Feet of Water | x 0.433 = PSI |
| Inches of Hg. | x 0.491 = PSI |
| Atmosphere | x 14.7 = PSI |
| Meters of Water | x 1.42 = PSI |
| Kilograms/sq. Centimeter | x 14.22 = PSI |
| Bar | x 14.7 = PSI |

Pressure (continued)

| | |
|---------------|------------------------|
| Atmosphere | x 33.9 = Feet of Water |
| PSI | x 2.31 = Feet of Water |
| Inches of Hg. | x 1.13 = Feet of Water |

Flow

| | |
|---------------------|-------------------------|
| Lbs. Of Water/Hour | x 0.002 = GPM |
| Lbs. Of Fluid/Hour | x 0.002 = GPM |
| Specific Gravity | |
| Cu. Meter/Hour | x 4.4 = GPM |
| Kg. Of Water/Minute | x 0.264 = GPM |
| Liters/Minute | x 0.264 = GPM |
| GPM | x 3.785 = Liters/Minute |

Power

$$\text{Liquid HP} = \frac{\text{GPM} \times \text{Head ft.} \times \text{Specific Gravity}}{3960}$$

$$\text{BHP} = \frac{\text{GPM} \times \text{Head ft.} \times \text{Specific Gravity}}{3960 \times \text{Pump Efficiency}}$$

Viscosity

$$\frac{\text{Centipoise}}{\text{Specific Gravity}} = \text{Centistokes}$$

$$\text{Centistokes} \times 4.64 = \text{SSU (Approx.)}$$

Temperature

$$(1.8 \times ^\circ\text{C}) + 32 = ^\circ\text{F}$$

$$.555 (^{\circ}\text{F} - 32^{\circ}) = ^\circ\text{C}$$

$$\text{Degrees Kelvin} - 273.2 = \text{Degrees Centigrade}$$

Vapor Pressure Chart

VAPOR PRESSURE OF WATER

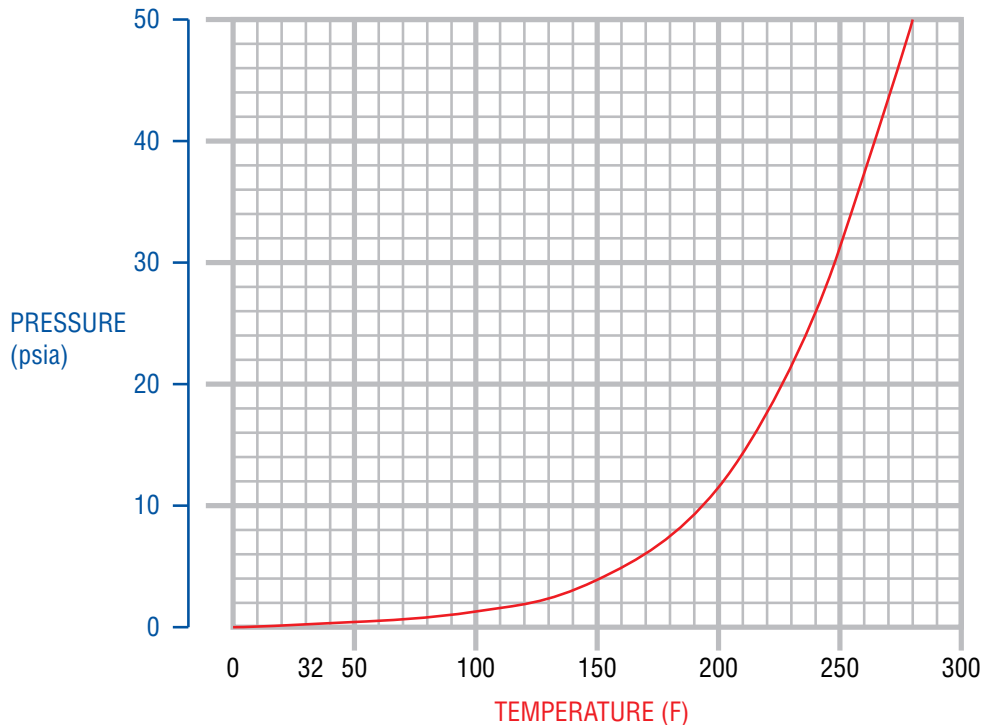

Loss of Head Due to Friction in Feet per Foot of Stainless Steel Tubing and in Feet for Sanitary Fittings

Notes:

1. Flow Elbows—R/D = 1.5
2. Flow Through Tees—Flow A to B Port C capped off.
3. Test Medium—Water at 70°F
4. 16 gauge tubing was used for the measurements when the outer diameter (O.D.) was between 1" - 3" and 14 gauge tubing was used with the 4" O.D. measurement.

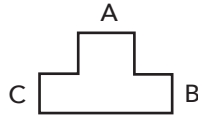

*Calculated data for estimating purposes only. Consult your tubing manufacturer with specific questions.

| Capacity in U.S. G.P.M. | O.D. - 1" I.D. - .870" | | | O.D. - 1.5" I.D. - 1.370" | | | O.D. - 2" I.D. - 1.870" | | | O.D. - 2.5" I.D. - 2.370" | | | O.D. - 3" I.D. - 2.870" | | | O.D. - 4" I.D. - 3.834" | | |
|-------------------------|---------------------------|-------|-----|------------------------------|-------|------|----------------------------|-------|------|------------------------------|-------|------|----------------------------|-------|------|----------------------------|-------|-----|
| | Tubing | Elbow | Tee | Tubing | Elbow | Tee | Tubing | Elbow | Tee | Tubing | Elbow | Tee | Tubing | Elbow | Tee | Tubing | Elbow | Tee |
| 2 | .01 | .01 | .1 | | | | | | | | | | | | | | | |
| 4 | .025 | .02 | .2 | | | | | | | | | | | | | | | |
| 5 | .035 | .025 | .25 | | | | | | | | | | | | | | | |
| 10 | .12 | .06 | .4 | .02 | .01 | .15 | .005 | .015 | .1 | | | | | | | | | |
| 15 | .25 | .1 | .8 | .04 | .02 | .25 | .013 | .02 | .15 | | | | | | | | | |
| 20 | .43 | .22 | 1.5 | .06 | .03 | .3 | .02 | .025 | .2 | .005 | .02 | .1 | .003 | .02 | .06 | | | |
| 25 | .66 | .4 | 2.3 | .08 | .04 | .4 | .025 | .03 | .25 | .006 | .03 | .15 | .004 | .03 | .08 | | | |
| 30 | .93 | .7 | 3.3 | .105 | .06 | .55 | .035 | .05 | .3 | .008 | .05 | .2 | .005 | .04 | .1 | | | |
| 35 | 1.22 | 1.25 | 5.2 | .135 | .09 | .8 | .04 | .06 | .4 | .011 | .06 | .25 | .006 | .05 | .13 | | | |
| 40 | | | | .17 | .11 | 1.0 | .05 | .08 | .5 | .015 | .07 | .3 | .007 | .06 | .15 | | | |
| 45 | | | | .21 | .16 | 1.3 | .063 | .1 | .6 | .02 | .09 | .35 | .008 | .065 | .18 | | | |
| 50 | | | | .25 | .2 | 1.6 | .073 | .12 | .7 | .022 | .1 | .4 | .01 | .07 | .2 | | | |
| 60 | | | | .34 | .35 | 2.2 | .1 | .18 | .9 | .03 | .12 | .45 | .015 | .08 | .25 | | | |
| 80 | | | | .57 | .76 | 3.7 | .16 | .3 | 1.5 | .05 | .15 | .55 | .02 | .1 | .4 | | | |
| 100 | | | | .85 | 1.35 | 5.8 | .23 | .44 | 2.3 | .075 | .18 | .6 | .03 | .11 | .5 | .008 | .04 | .1 |
| 120 | | | | 1.18 | 2.05 | 9.1 | .32 | .64 | 3.3 | .105 | .21 | 1.0 | .04 | .13 | .6 | .01 | .05 | .15 |
| 140 | | | | | | .42 | .85 | 4.5 | .14 | .23 | 1.25 | .05 | .16 | .8 | .013 | .06 | .2 | |
| 160 | | | | | | .54 | 1.13 | 5.8 | .17 | .28 | 1.6 | .07 | .2 | 1.1 | .015 | .07 | .25 | |
| 180 | | | | | | .67 | 1.45 | 7.4 | .205 | .31 | 2.0 | .08 | .21 | 1.3 | .02 | .08 | .3 | |
| 200 | | | | | | .81 | 1.82 | 9.0 | .245 | .35 | 2.5 | .1 | .26 | 1.6 | .025 | .09 | .4 | |
| 220 | | | | | | .95 | 2.22 | 11.0 | .29 | .41 | 3.0 | .12 | .3 | 1.9 | .028 | .1 | .5 | |
| 240 | | | | | | 1.10 | 2.63 | 13.5 | .34 | .48 | 3.7 | .14 | .33 | 2.2 | .035 | .11 | .55 | |
| 260 | | | | | | | | | .39 | .53 | 4.5 | .165 | .39 | 2.5 | .04 | .115 | .6 | |
| 280 | | | | | | | | | .45 | .61 | 5.3 | .19 | .42 | 2.8 | .045 | .12 | .65 | |
| 300 | | | | | | | | | .515 | .7 | 6.2 | .22 | .5 | 3.1 | .05 | .13 | .7 | |
| 350 | | | | | | | | | .68 | 1.05 | 8.5 | .28 | .67 | 4.1 | .07 | .15 | .9 | |
| 400 | | | | | | | | | .86 | 1.55 | 11.0 | .36 | .88 | 5.2 | .085 | .18 | 1.2 | |
| 450 | | | | | | | | | 1.05 | 2.25 | 13.5 | .44 | 1.1 | 6.6 | .105 | .2 | 1.5 | |
| 500 | | | | | | | | | | | | .54 | 1.4 | 8.0 | .13 | .23 | 1.75 | |
| 550 | | | | | | | | | | | | .64 | 1.7 | 9.5 | .15 | .27 | 2.1 | |
| 600 | | | | | | | | | | | | .75 | 2.05 | 10.2 | .175 | .3 | 2.5 | |
| 650 | | | | | | | | | | | | .87 | 2.41 | 13.0 | .2 | .34 | 2.8 | |
| 700 | | | | | | | | | | | | 1.0 | 2.8 | 15.0 | .23 | .4 | 3.4 | |
| 750 | | | | | | | | | | | | | | | | .26 | .43 | 3.8 |
| 800 | | | | | | | | | | | | | | | | .3 | .5 | 4.4 |
| 850 | | | | | | | | | | | | | | | | .33 | .56 | 5.0 |
| 900 | | | | | | | | | | | | | | | | .37 | .62 | 5.7 |
| 950 | | | | | | | | | | | | | | | | .41 | .7 | 6.3 |
| 1000 | | | | | | | | | | | | | | | | .45 | .8 | 7.0 |
| 1100 | | | | | | | | | | | | | | | | .53 | 1.06 | 8.6 |

Fristam Centrifugal Options

SEAL MATERIALS

1st – Rotating
2nd – Stationary
3rd – Flush (Double) Seal [FP and FPR only]

Single Seal

FR-N – Chrome oxide SS vs. carbon
C-N – Silicon carbide vs. carbon
C-C – Silicon carbide vs. silicon carbide
FR-C – Chrome oxide SS vs. silicon carbide

Double Seal [FP and FPR only]

FR-N-N – Chrome oxide SS vs. carbon vs. carbon
C-N-N – Silicon carbide vs. carbon vs. carbon
C-C-N – Silicon carbide vs. silicon carbide vs. carbon
FR-C-N – Chrome oxide SS vs. silicon carbide vs. carbon

FITTING TYPE

Clamp
Bevel seat
150# flange
300# flange
NPT
DIN
Butt weld
I-Line (female)
Others

FINISH AND MATERIAL OPTIONS

32 Ra
25 Ra
20 Ra
15 Ra
Electropolish
Passivation
Tungsten carbide coating
316L low ferrite

HARDWARE OPTIONS

Stainless steel flange
Aseptic
Jacketed housing
Casing drain
Bearing block mounted
Adjustable base with legs
Impeller inducer

ELASTOMERS

Viton
EPDM
Buna cover gasket
Perfluoroelastomer
USP Class VI Viton and EPDM

COMPREHENSIVE DOCUMENTATION PACKAGE

Fristam offers the most comprehensive documentation package, with complete traceability of all parts, including elastomers.

Certified Drawings
Mill Certification
Material Verification
Conformance
Warranty Statement
Certified Finish
Passivation of Pump
Stainless Steel Tag
Paper Location Tag
Certified Welding
Hydrostatic Test
Dynamic Seal Test
Short Run Test
Performance Test
NPSH Test
Witness Test
Vibration Test
Ferrite Test

Pharmaceutical Options

All standard stainless steel components are 316L. Special castings are available in low-ferrite stainless steel or high-performance alloys such as Hastelloy® and AL-6XN®. Class VI elastomers are standard for pharmaceutical applications.

Electropolishing and enhanced internal surface finishes to 15 Ra are available on most products.

Casing drain and mounting options provide complete drainability critical for long-term system cleanliness. Pumps can be easily configured for steam-in-place sterilization, with no external cooling devices required.

Water For Injection (WFI) Pumps

Fristam is the industry leader for WFI and other high-purity service. Fristam WFI centrifugal pumps are a precision adaptation of our FP, FPX, and FPR pumps. They feature an advanced seal design that protects product sterility, saves valuable product and provides for long seal life.

Fristam pioneered a pressurized double seal flush system that ensures product sterility and saves valuable product by maintaining positive pressure in the critical seal area. The internal seal design provides extra cooling and lubrication on the front seal face to significantly extend seal life and provide for more system uptime.

Numerous seal and piping configurations, including single seal piping, are available to meet your processing requirements.

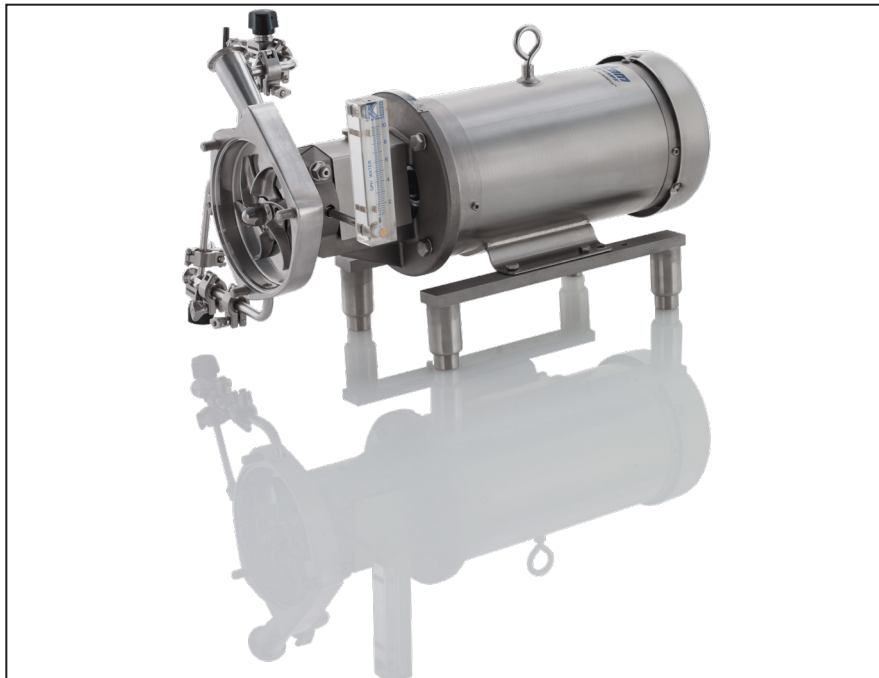

Comprehensive Documentation Options

- Certified Drawings
- Mill Certification
- Physical Certifications
- Material Verification
- Certificate of Conformance
- Certified Finish
- Passivation Certificate
- Certified Welding
- Hydrostatic Test
- Short Run Test
- Performance Test
- NPSH Test
- Witness Test
- Vibration Test
- Noise Test

FP/FPX/FPR Performance Curves
Models: 1750 RPM (Composite "A")
Maximum Flow: 400 GPM

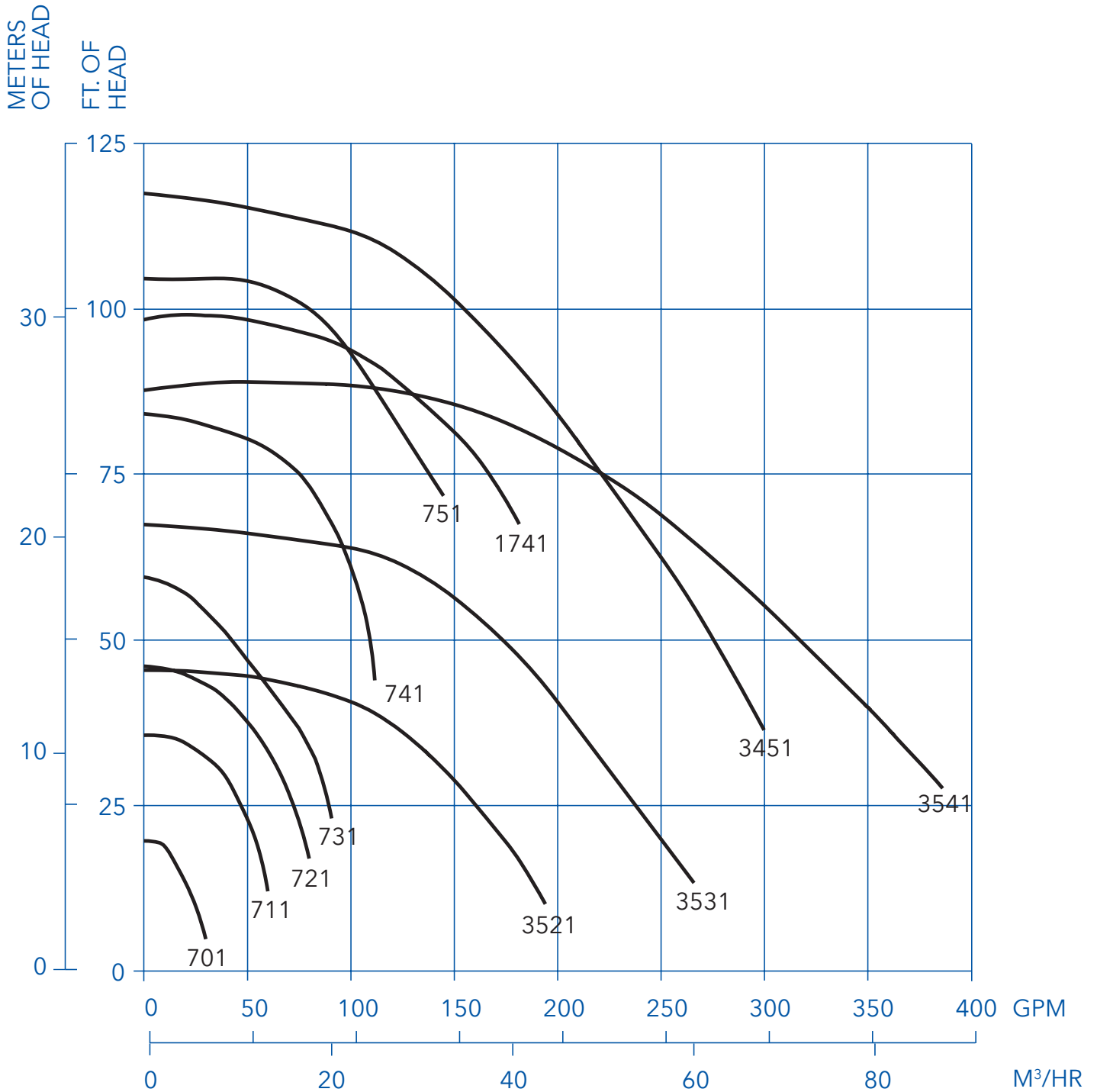

Performance curve based on tests using 70°F water and 0 psig inlet pressure. A tolerance of ± 5% applies to all figures. Actual performance may vary by application product. Please contact Fristam for different conditions.

FP/FPX/FPR Performance Curves
 Models: 1750 RPM (Composite "B")
 Maximum Flow: 2000 GPM

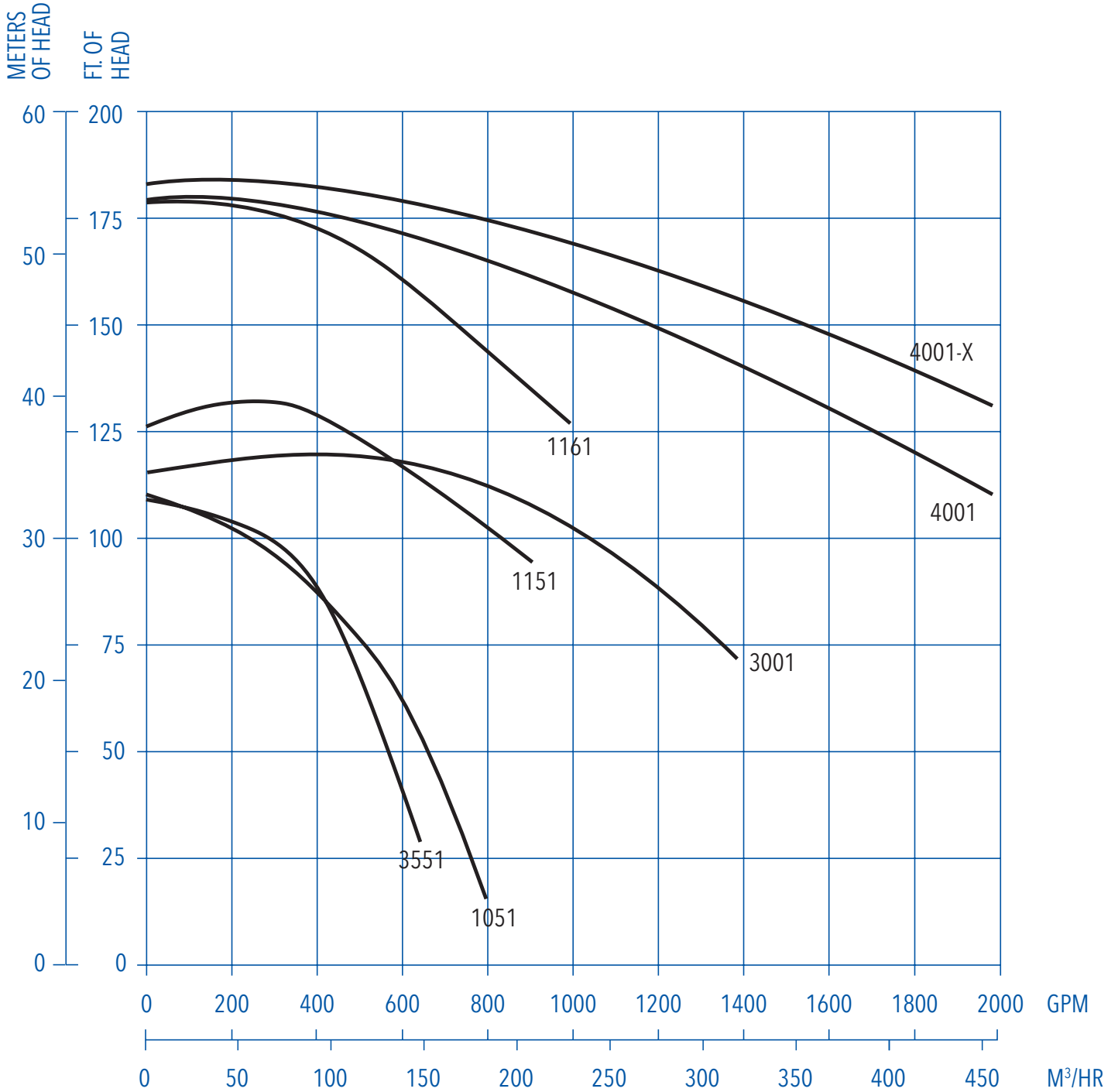

Performance curve based on tests using 70°F water and 0 psig inlet pressure. A tolerance of ± 5% applies to all figures. Actual performance may vary by application product. Please contact Fristam for different conditions.

FP/FPX/FPR Performance Curves

Model: 701 (1750 RPM, Inlet 1.5", Outlet 1.5")

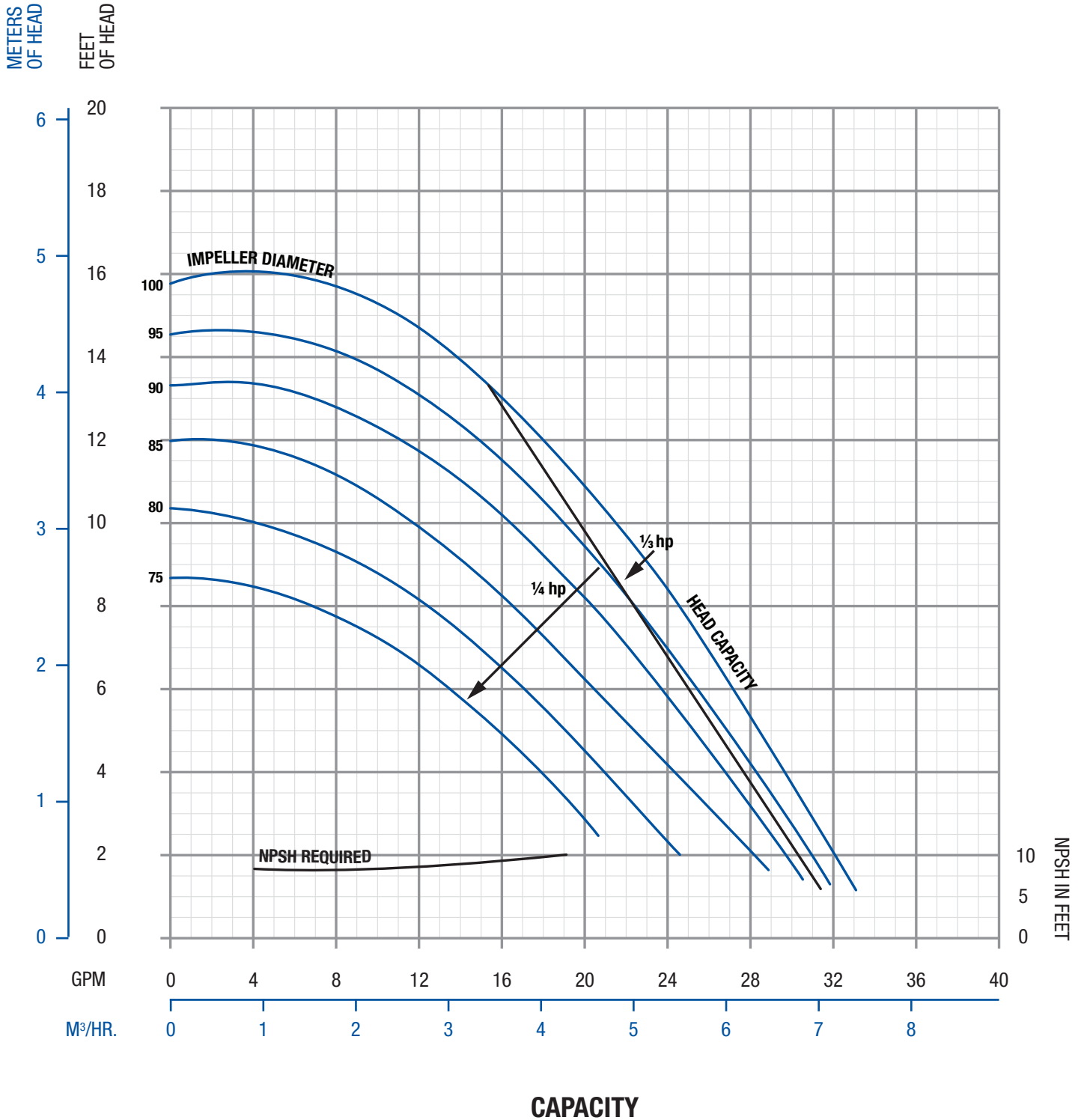

Performance curve based on tests using 70°F water and 0 psig inlet pressure. A tolerance of ± 5% applies to all figures. Actual performance may vary by application product. Please contact Fristam for different conditions.

FP/FPX/FPR Performance Curves

Model: 711 (1750 RPM, Inlet 2", Outlet 1.5")

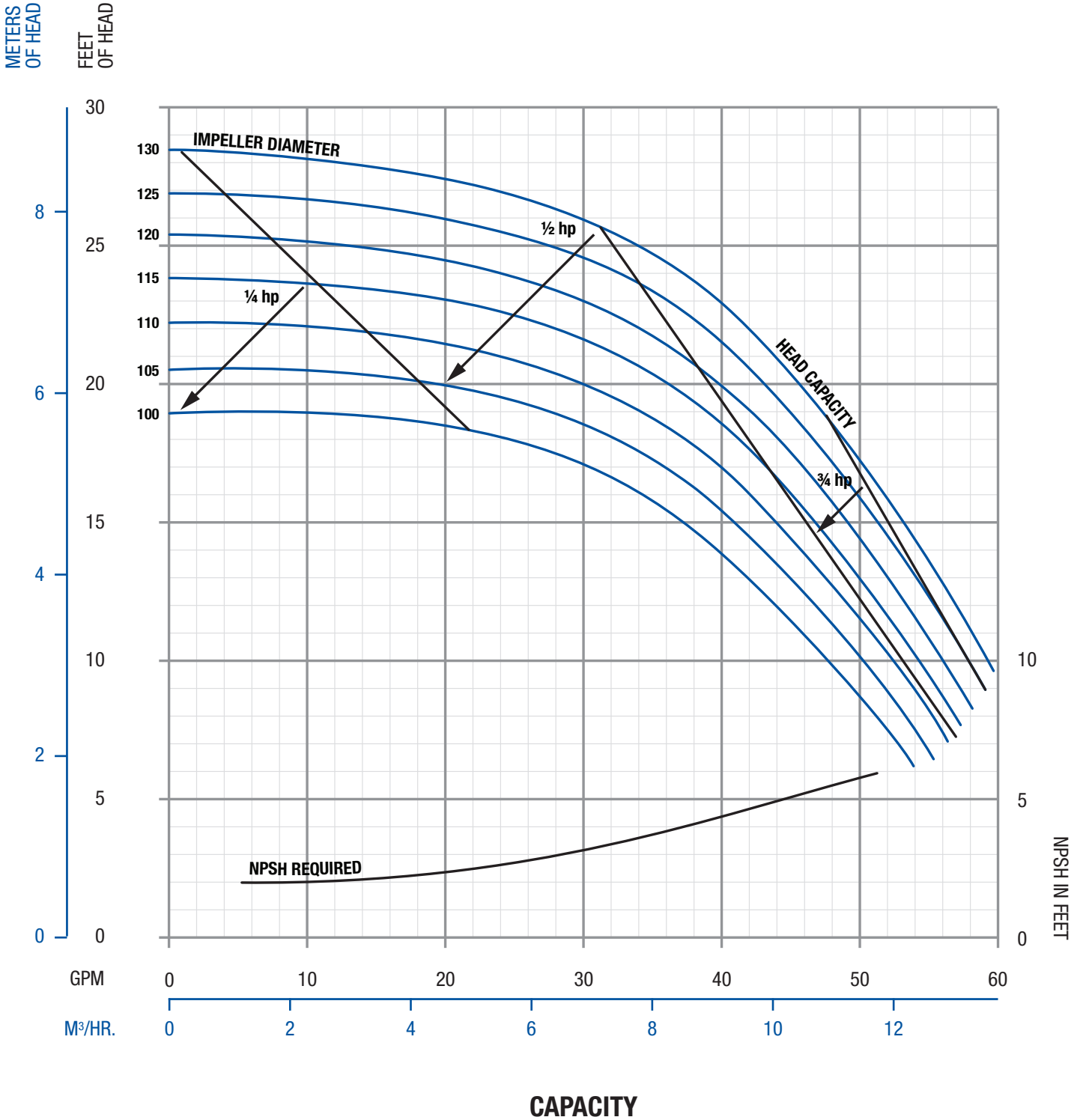

Performance curve based on tests using 70°F water and 0 psig inlet pressure. A tolerance of ± 5% applies to all figures. Actual performance may vary by application product. Please contact Fristam for different conditions.

FP/FPX/FPR Performance Curves

Model: 721 (1750 RPM, Inlet 2", Outlet 1.5")

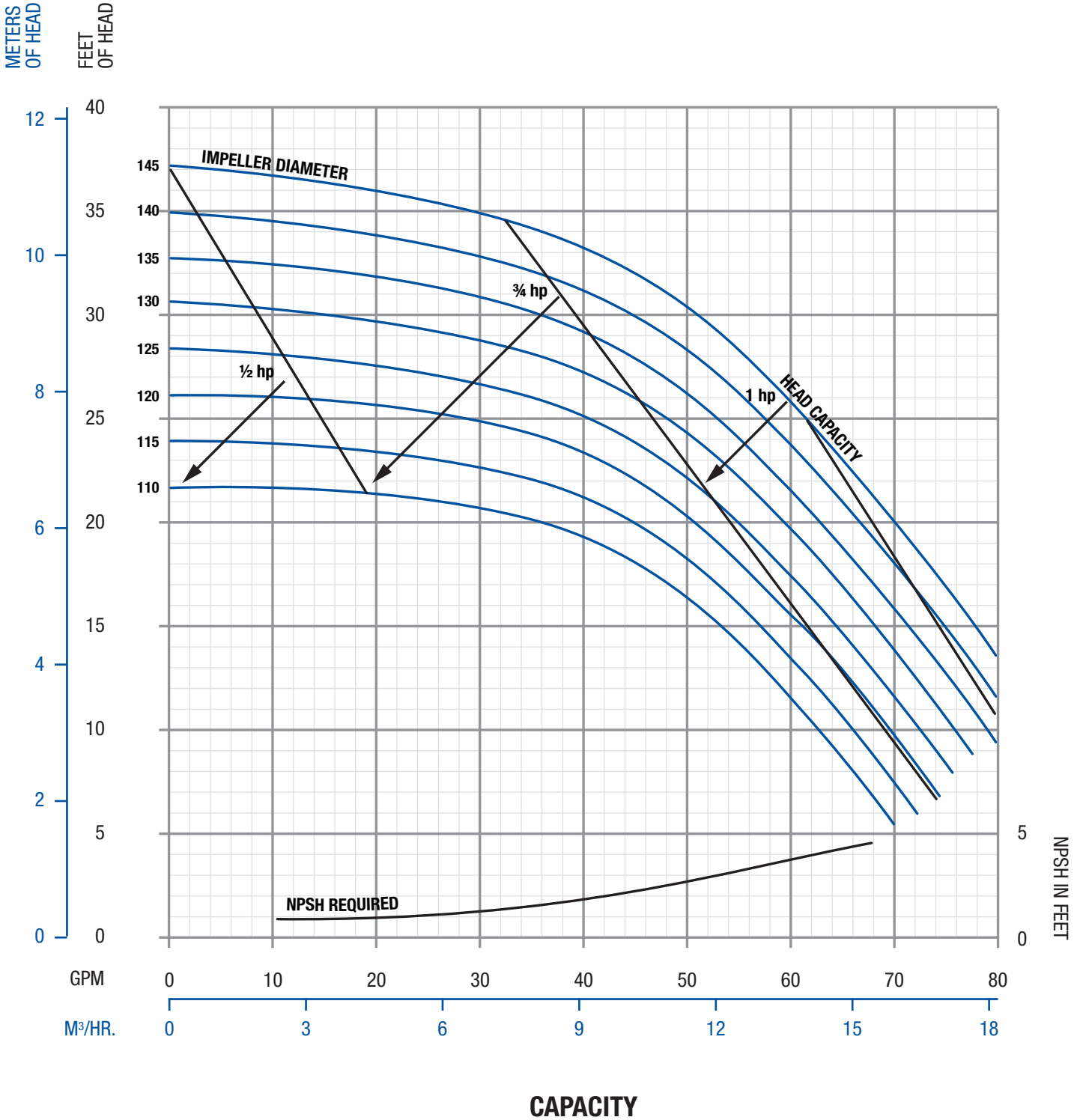

Performance curve based on tests using 70°F water and 0 psig inlet pressure. A tolerance of ± 5% applies to all figures. Actual performance may vary by application product. Please contact Fristam for different conditions.

FP/FPX/FPR Performance Curves

Model: 3521 (1750 RPM, Inlet 2.5", Outlet 2")

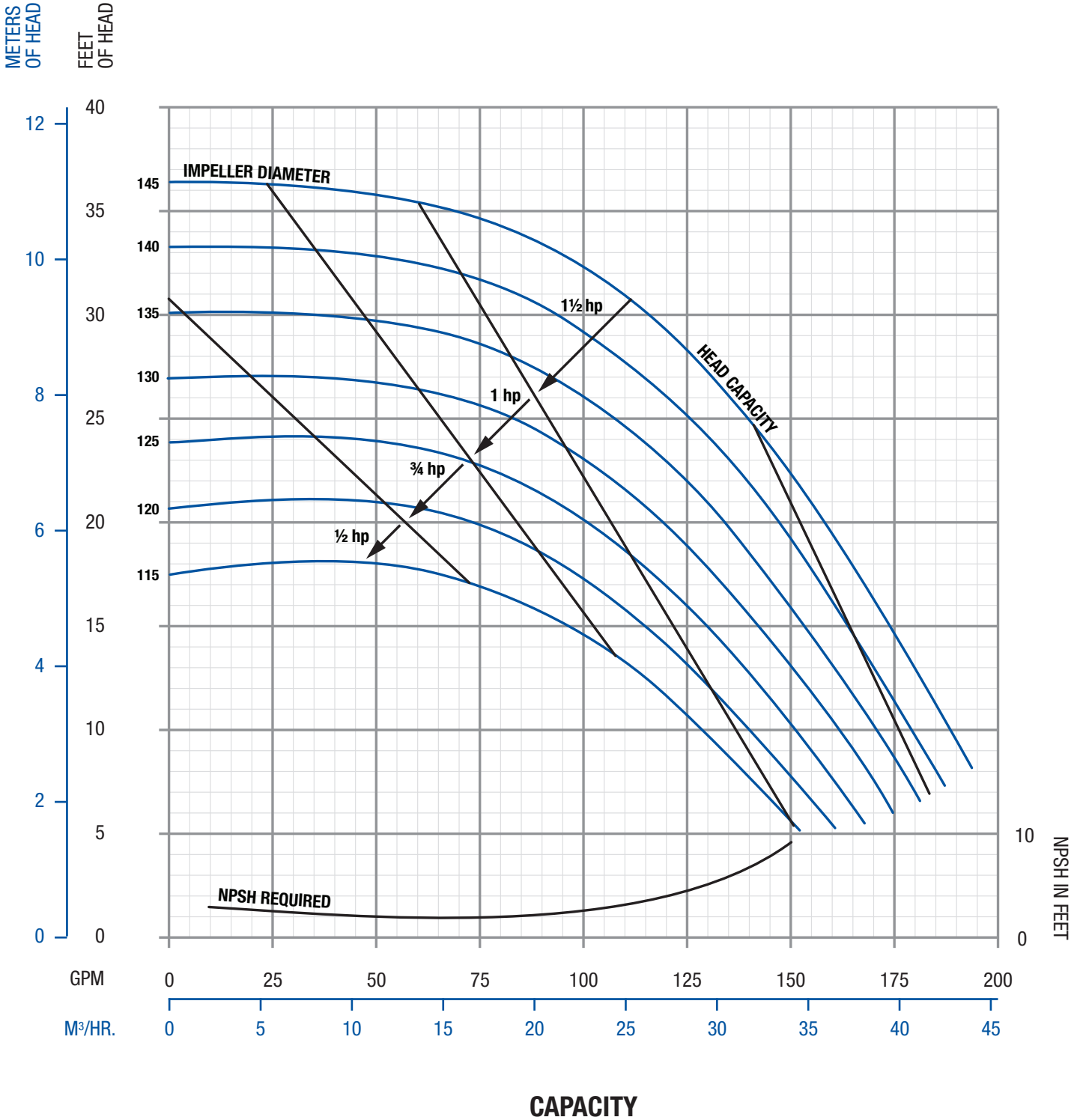

Performance curve based on tests using 70°F water and 0 psig inlet pressure. A tolerance of ± 5% applies to all figures. Actual performance may vary by application product. Please contact Fristam for different conditions.

FP/FPX/FPR Performance Curves

Model: 731 (1750 RPM, Inlet 2", Outlet 1.5")

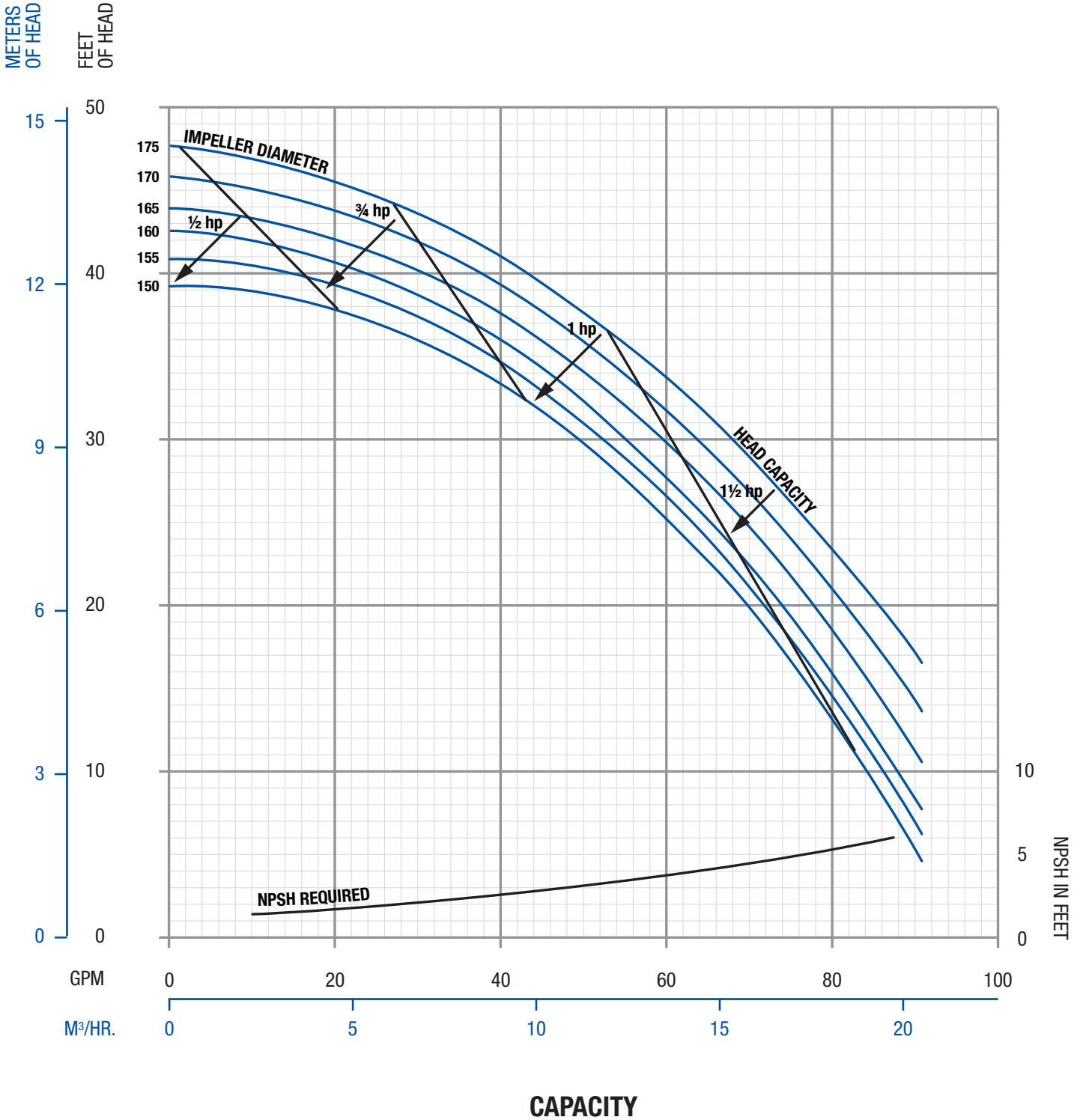

Performance curve based on tests using 70°F water and 0 psig inlet pressure. A tolerance of ± 5% applies to all figures. Actual performance may vary by application product. Please contact Fristam for different conditions.

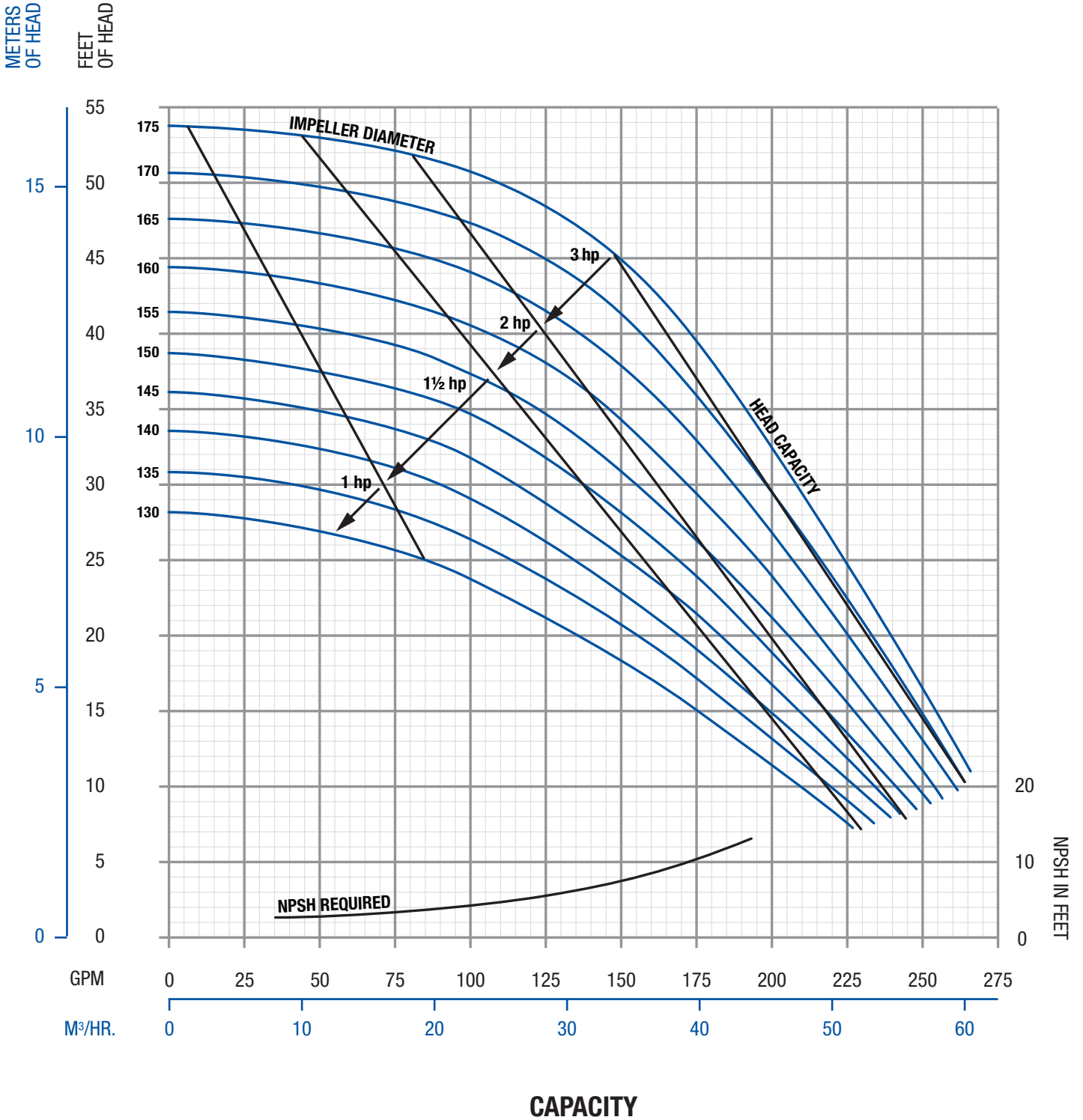

Performance curve based on tests using 70°F water and 0 psig inlet pressure. A tolerance of ± 5% applies to all figures. Actual performance may vary by application product. Please contact Fristam for different conditions.

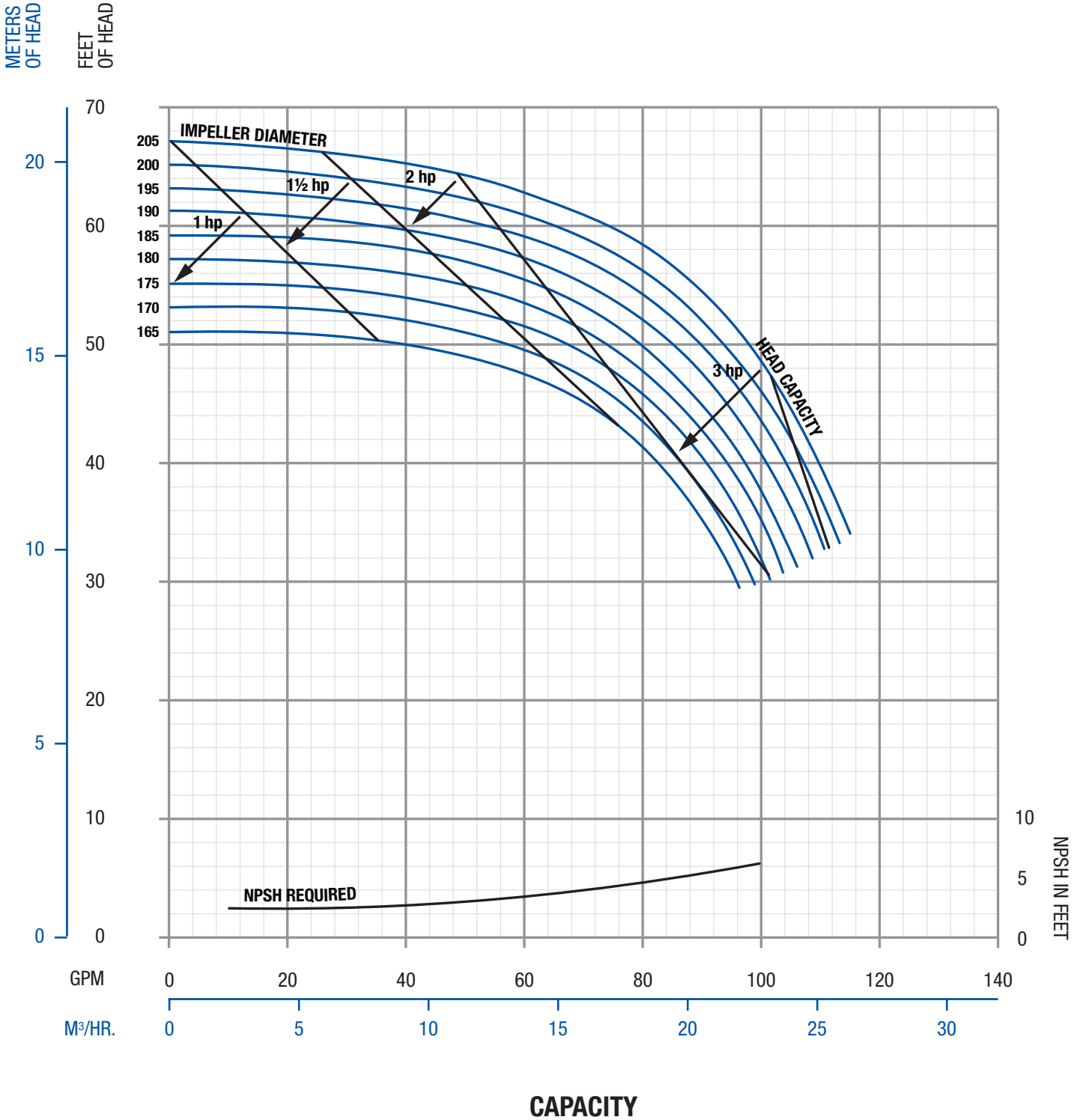

Performance curve based on tests using 70°F water and 0 psig inlet pressure. A tolerance of ± 5% applies to all figures. Actual performance may vary by application product. Please contact Fristam for different conditions.

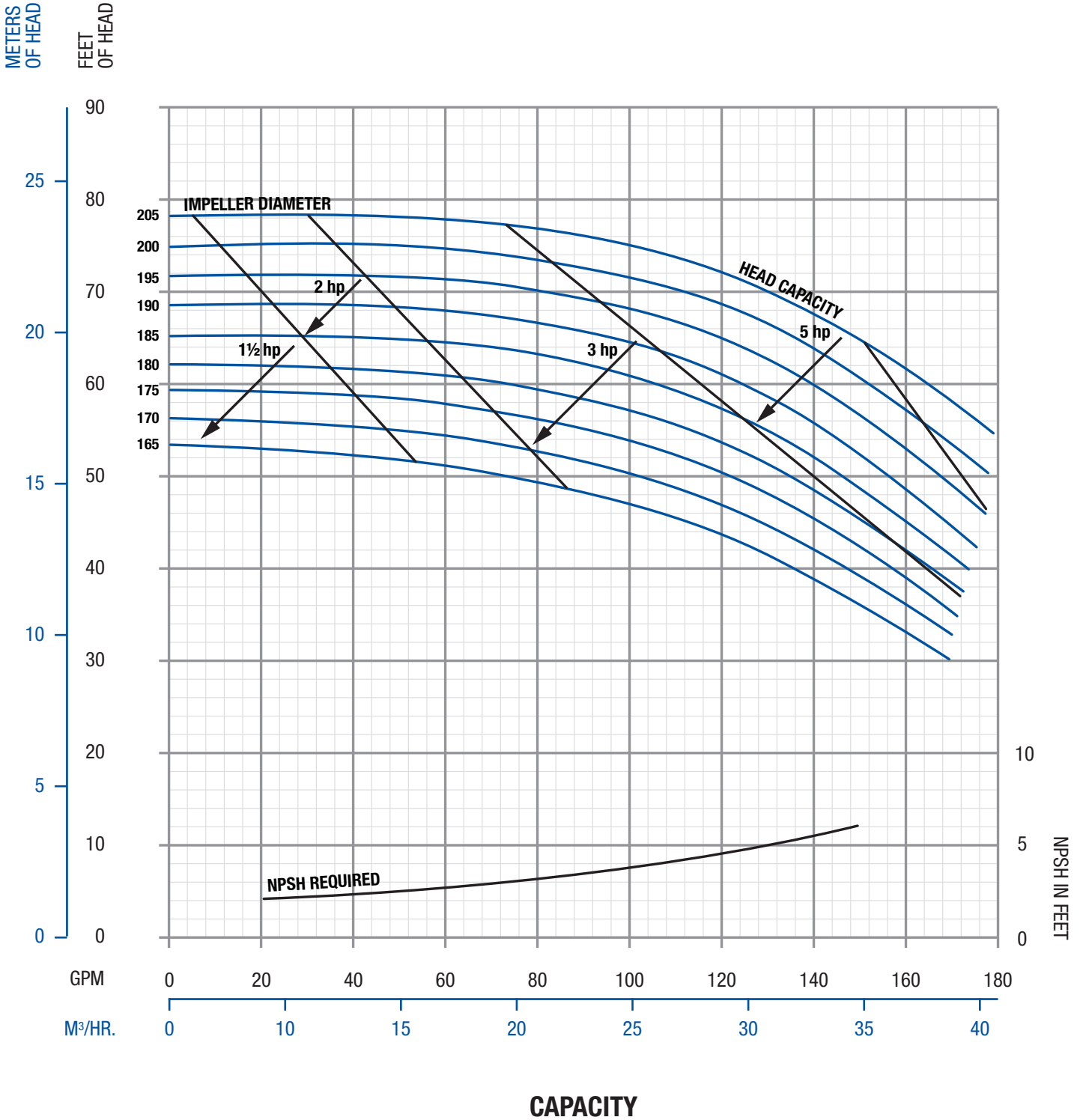

Performance curve based on tests using 70°F water and 0 psig inlet pressure. A tolerance of ± 5% applies to all figures. Actual performance may vary by application product. Please contact Fristam for different conditions.

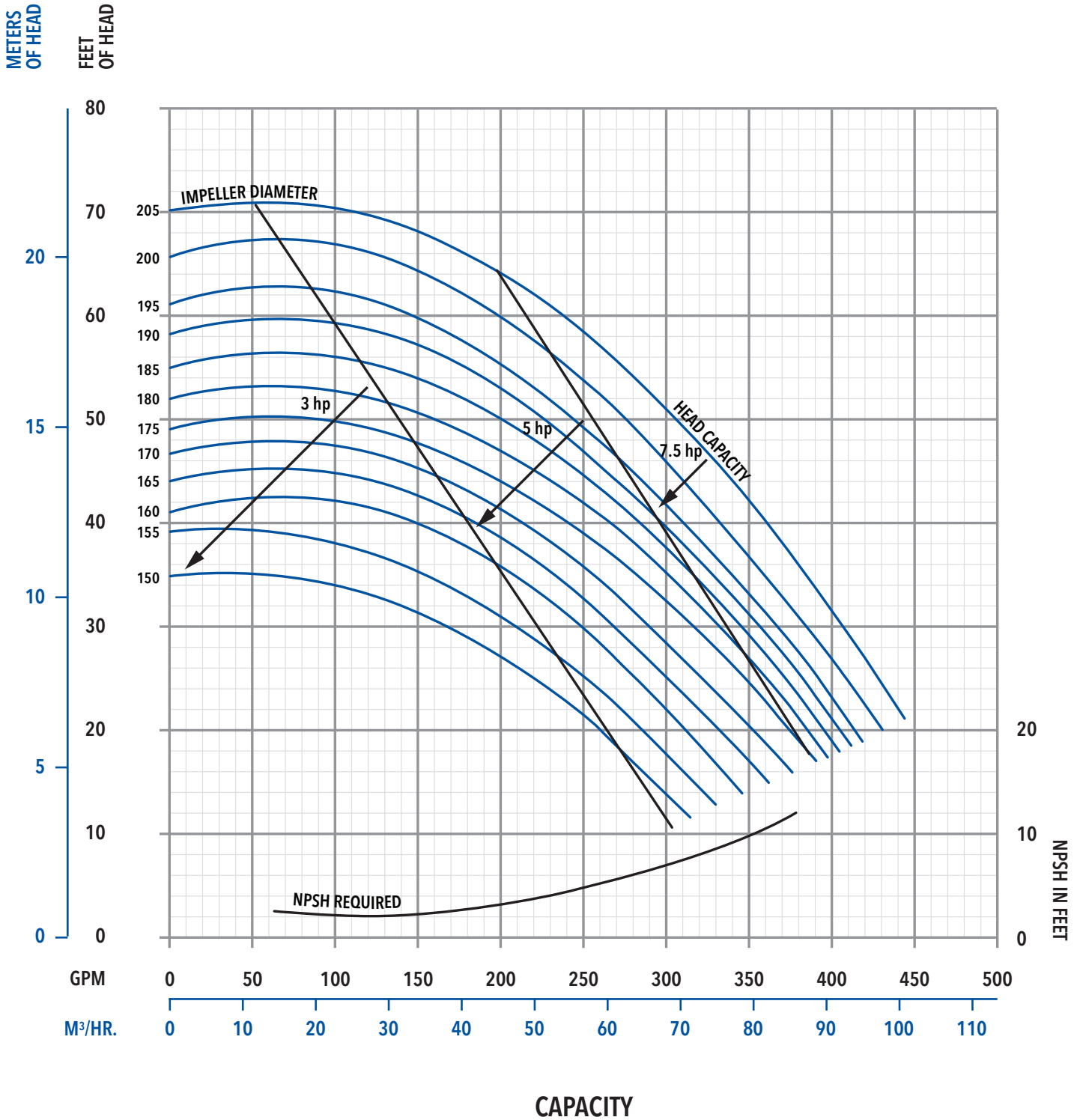

Performance curve based on tests using 70°F water and 0 psig inlet pressure. A tolerance of ± 5% applies to all figures. Actual performance may vary by application product. Please contact Fristam for different conditions.

FPR Performance Curves

Model: 751 (1750 RPM, Inlet 3", Outlet 2")

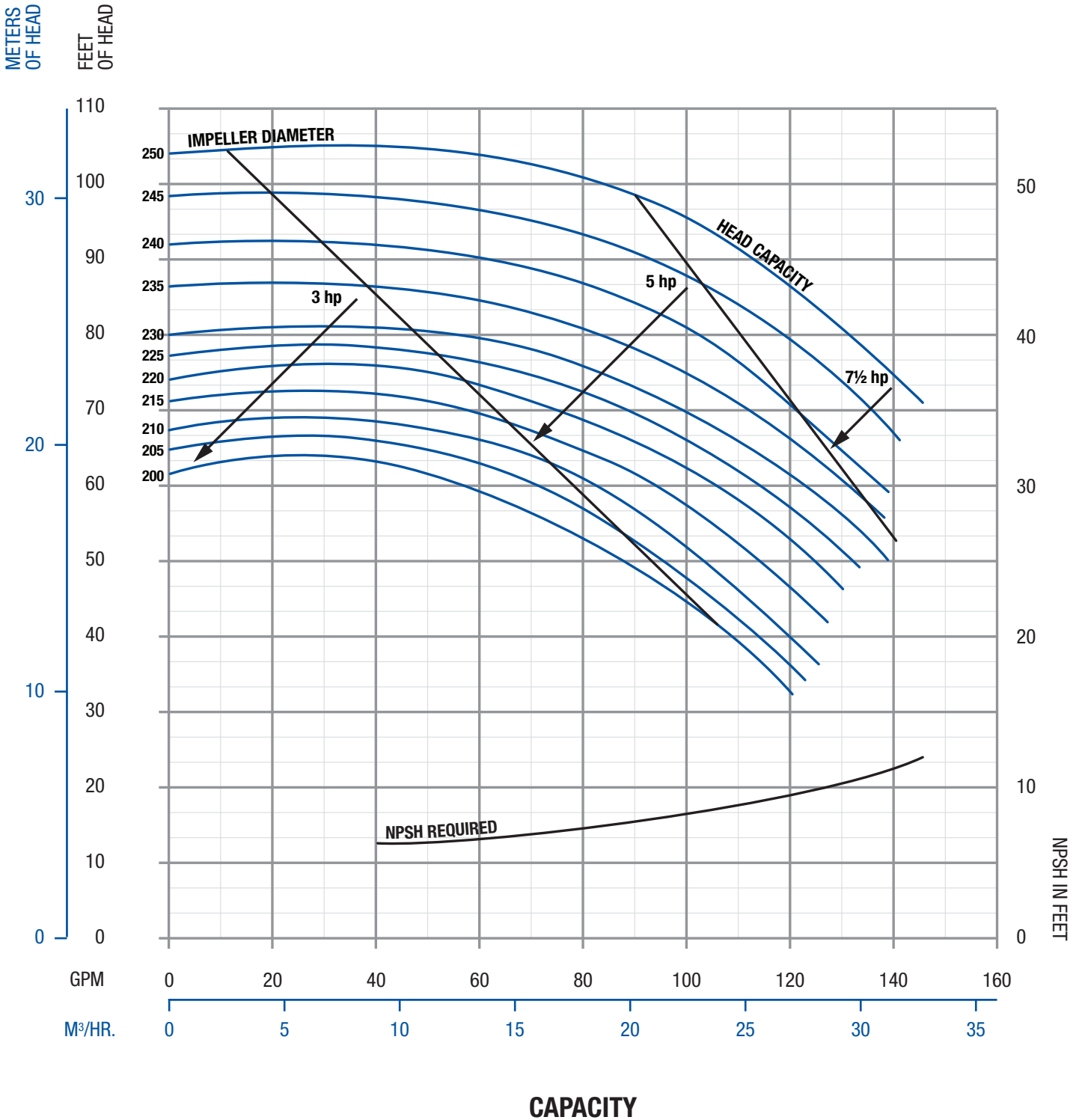

Performance curve based on tests using 70°F water and 0 psig inlet pressure. A tolerance of ± 5% applies to all figures. Actual performance may vary by application product. Please contact Fristam for different conditions.

FP/FPX/FPR Performance Curves

Model: 3451 (1750 RPM, Inlet 3", Outlet 2")

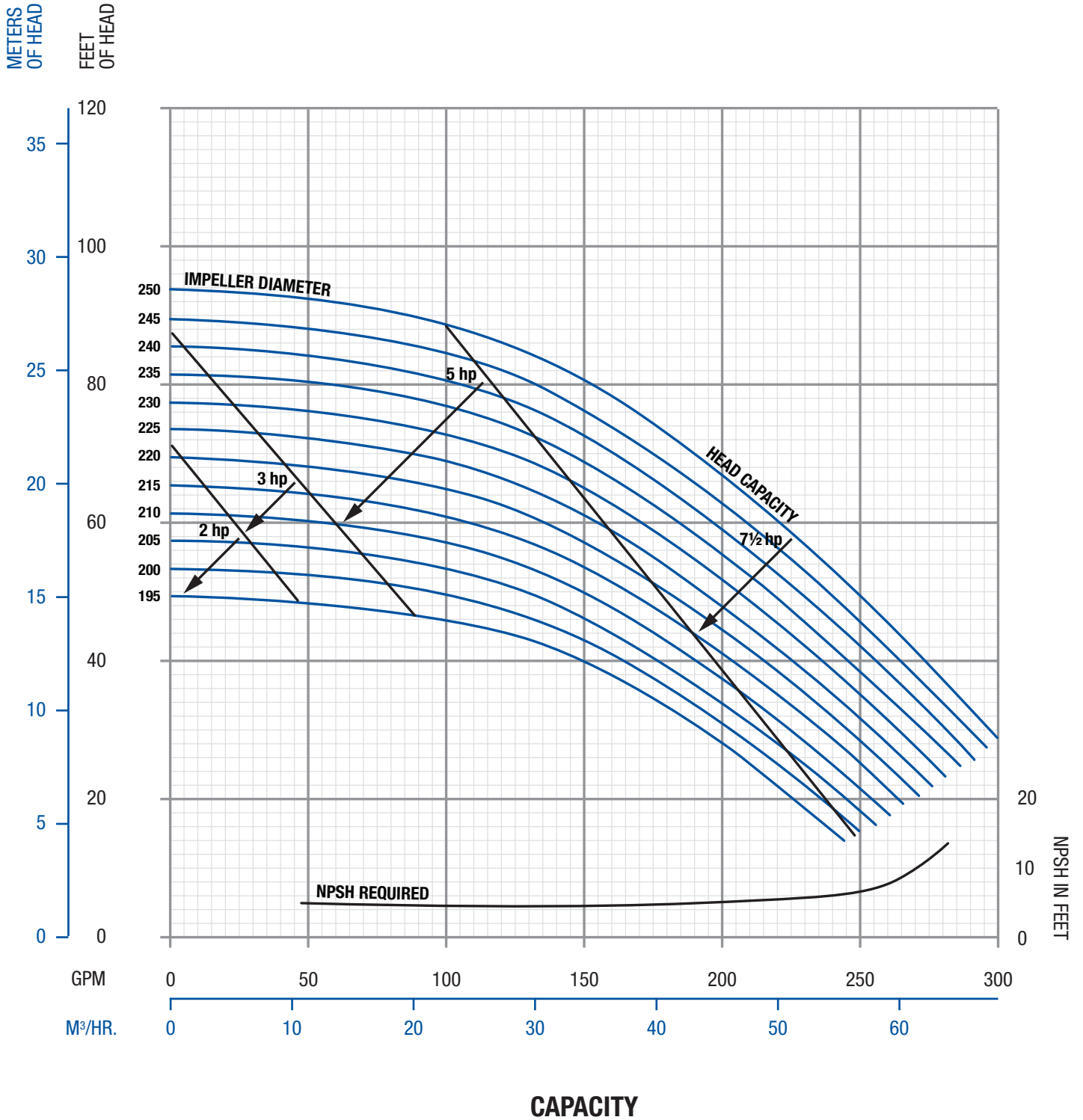

Performance curve based on tests using 70°F water and 0 psig inlet pressure. A tolerance of ± 5% applies to all figures. Actual performance may vary by application product. Please contact Fristam for different conditions.

FP/FPX/FPR Performance Curves

Model: 3551 (1750 RPM, Inlet 3", Outlet 2.5")

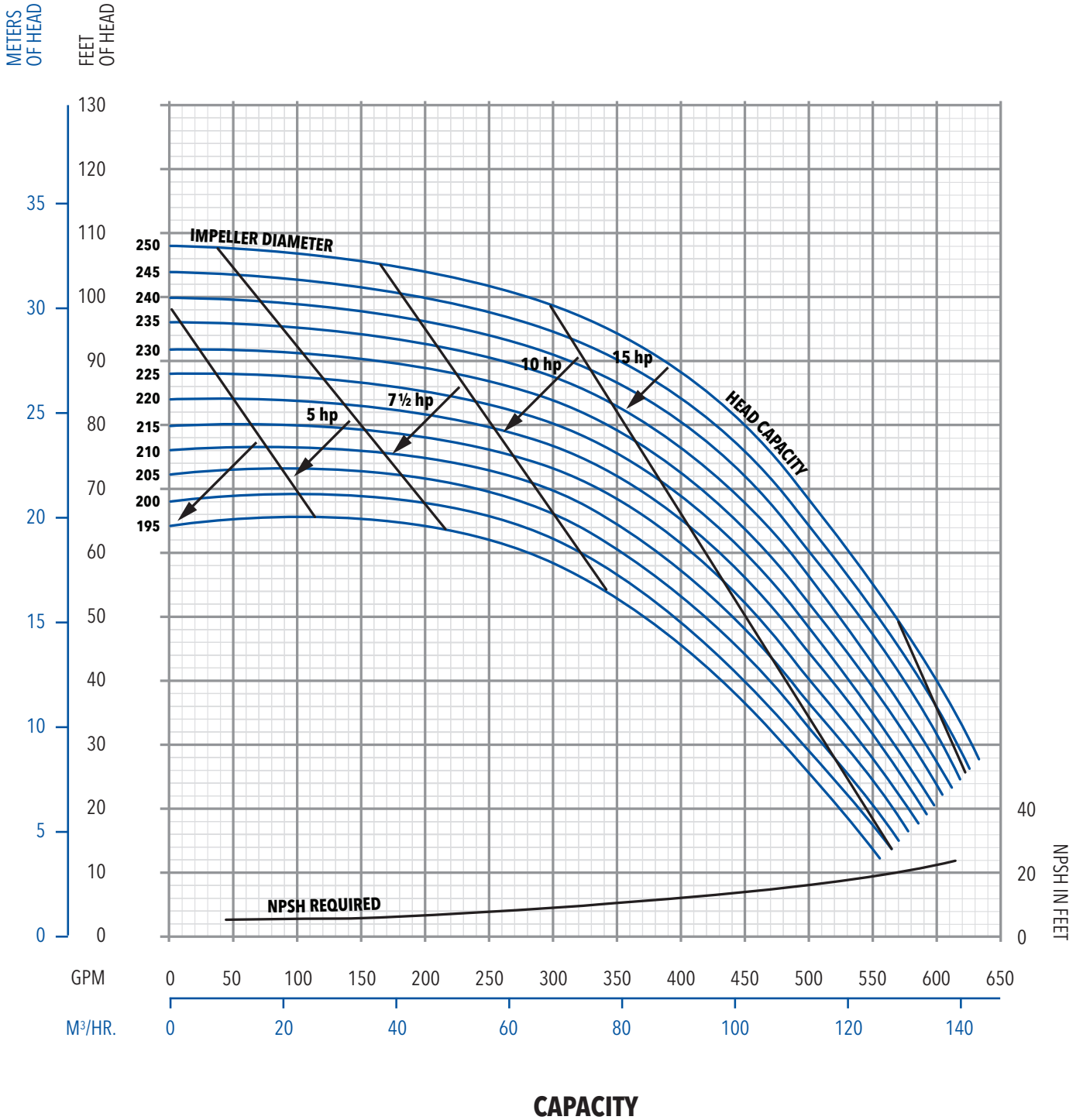

Performance curve based on tests using 70°F water and 0 psig inlet pressure. A tolerance of ± 5% applies to all figures. Actual performance may vary by application product. Please contact Fristam for different conditions.

FP/FPX/FPR Performance Curves

Model: 1051 (1750 RPM, Inlet 4", Outlet 4")

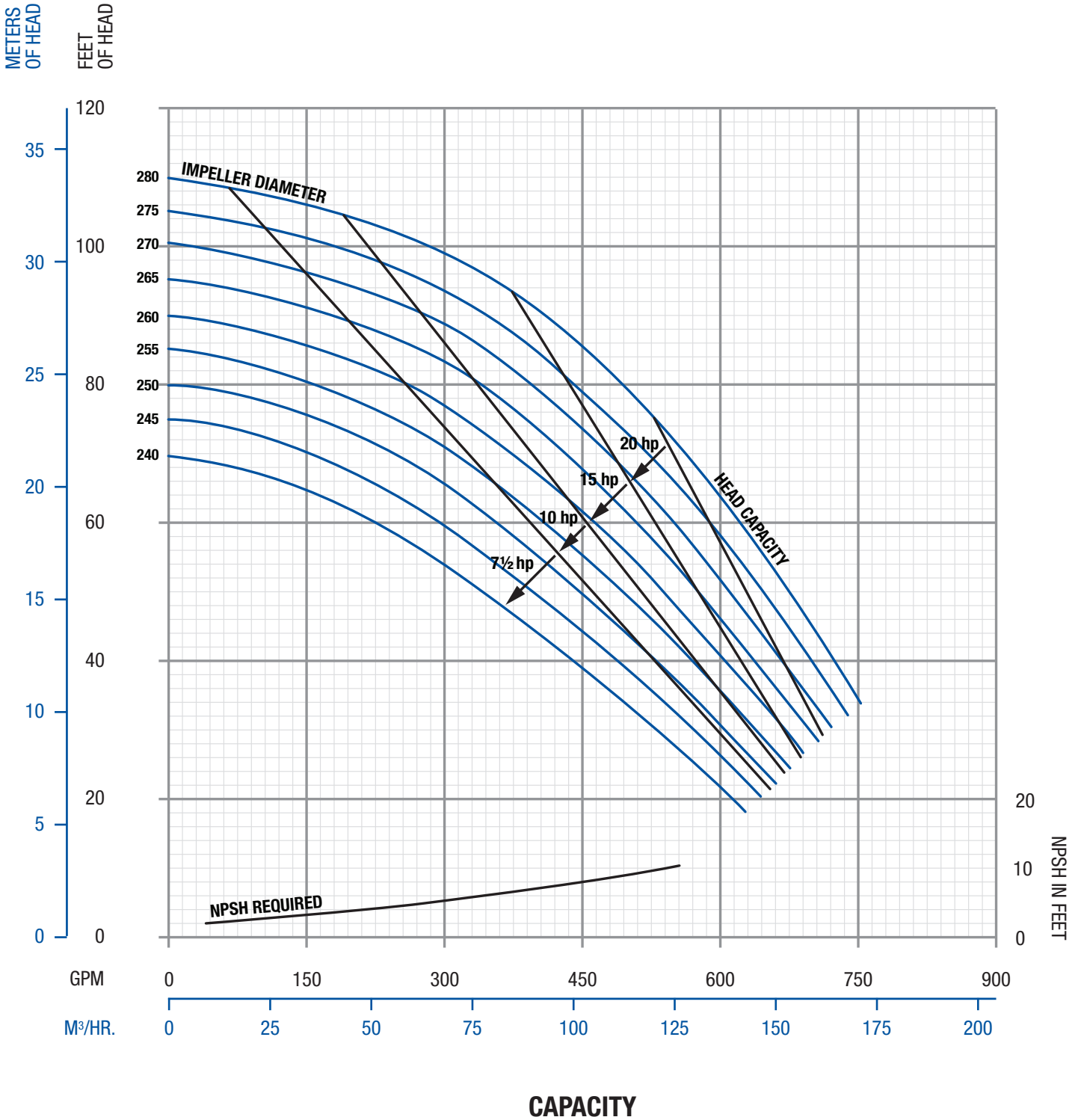

Performance curve based on tests using 70°F water and 0 psig inlet pressure. A tolerance of ± 5% applies to all figures. Actual performance may vary by application product. Please contact Fristam for different conditions.

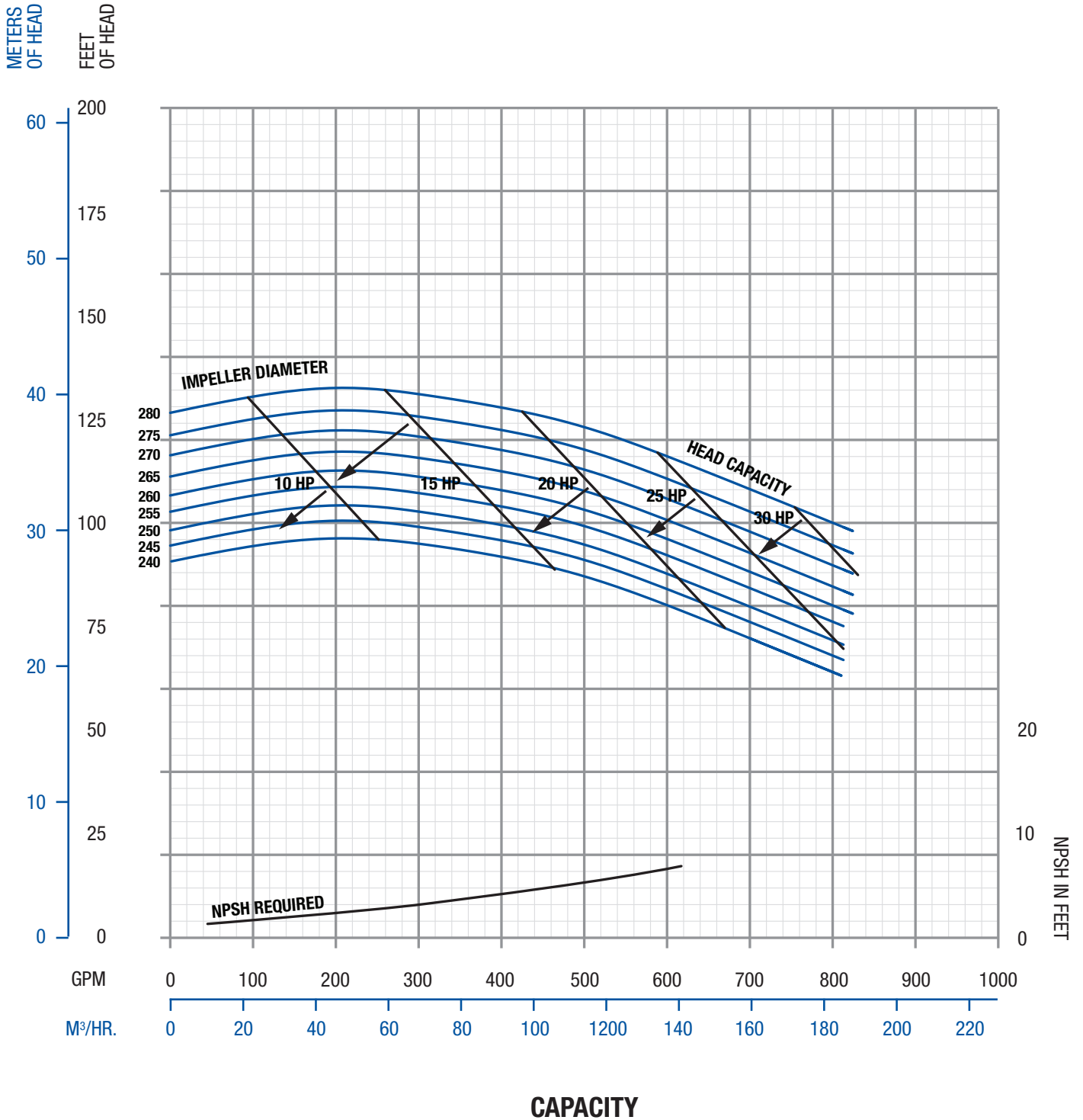

Performance curve based on tests using 70°F water and 0 psig inlet pressure. A tolerance of ± 5% applies to all figures. Actual performance may vary by application product. Please contact Fristam for different conditions.

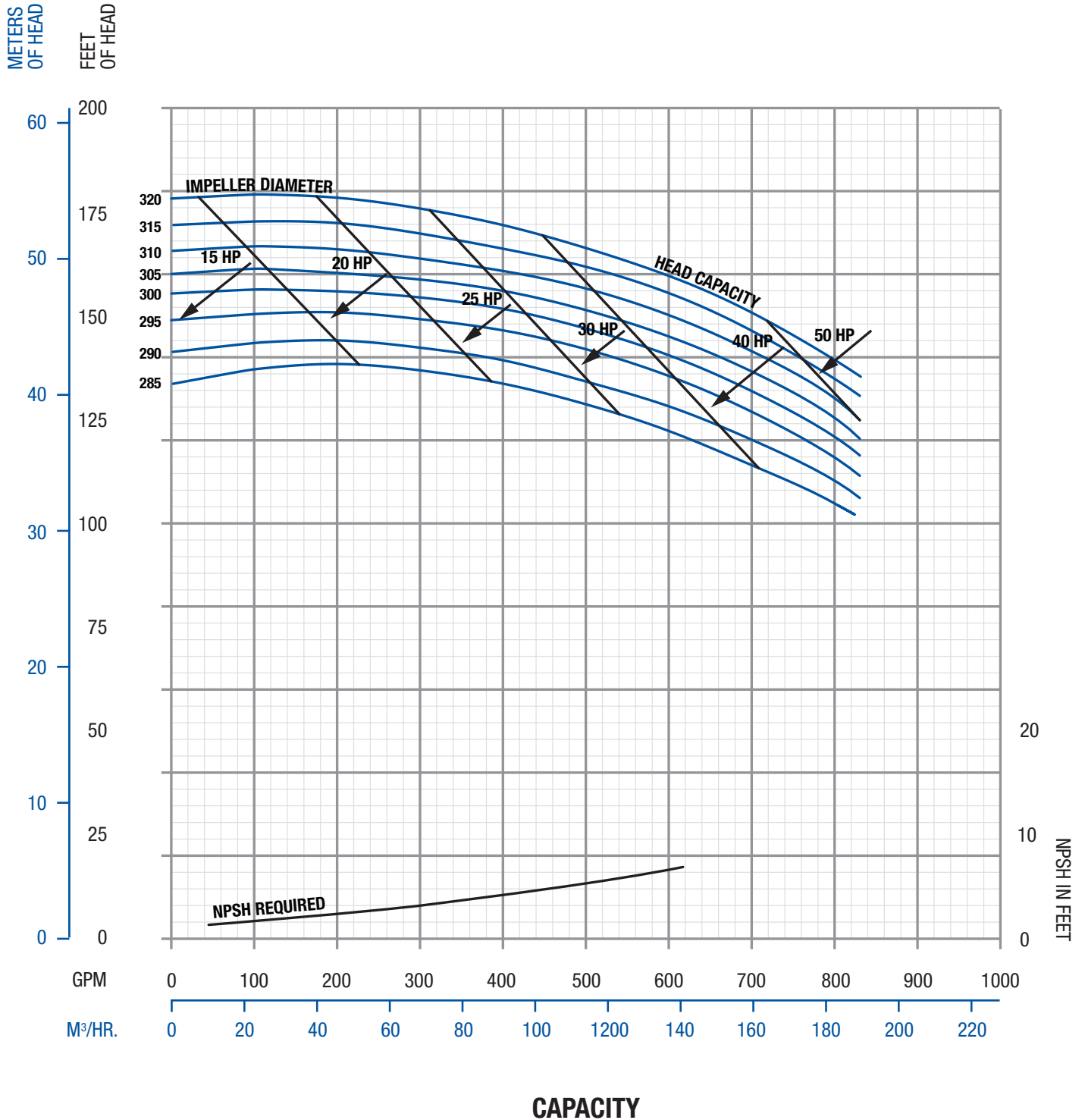

Performance curve based on tests using 70°F water and 0 psig inlet pressure. A tolerance of ± 5% applies to all figures. Actual performance may vary by application product. Please contact Fristam for different conditions.

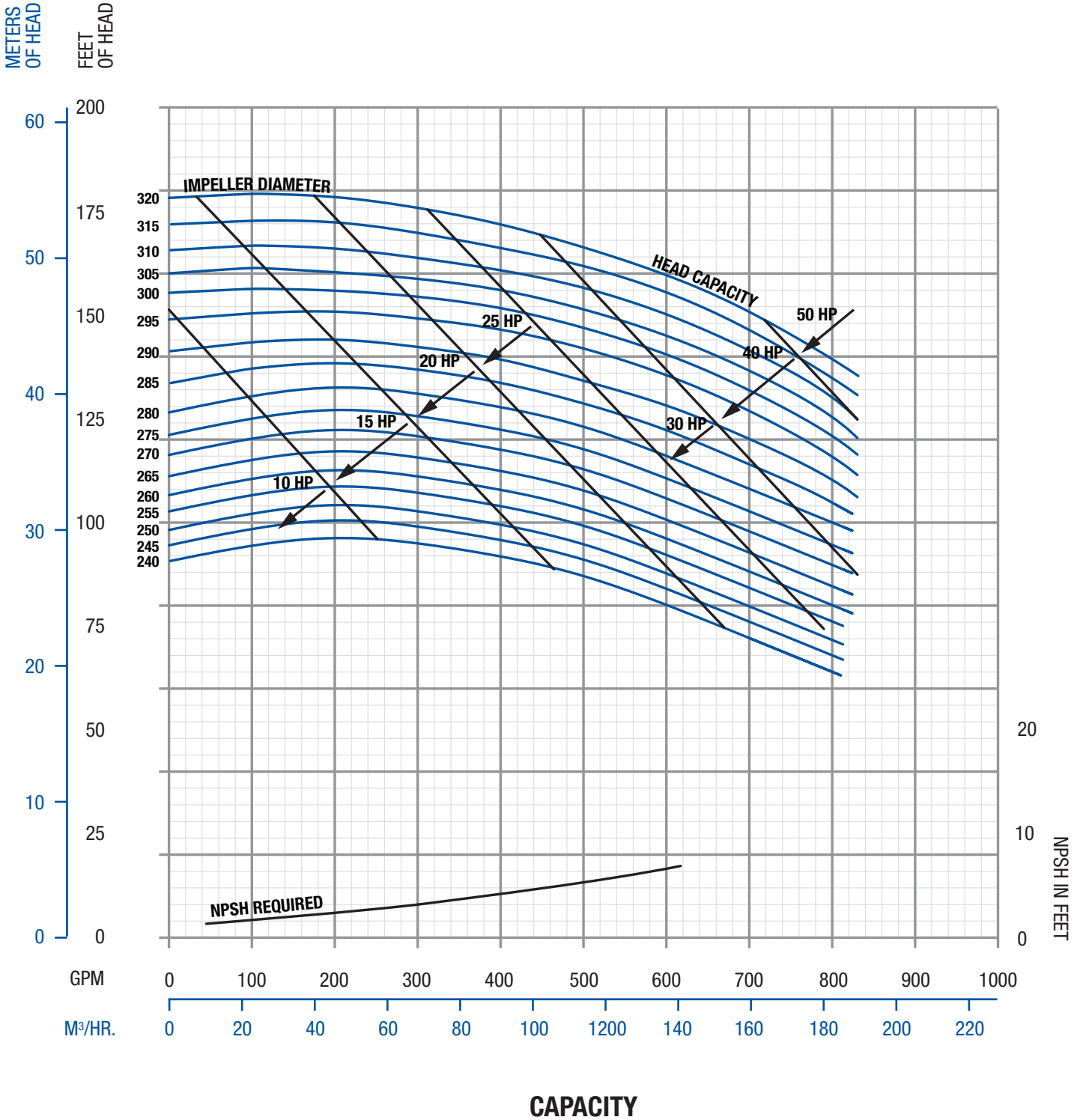

Performance curve based on tests using 70°F water and 0 psig inlet pressure. A tolerance of ± 5% applies to all figures. Actual performance may vary by application product. Please contact Fristam for different conditions.

FPR Performance Curves

Model: 3001 (1750 RPM, Inlet 4", Outlet 4")

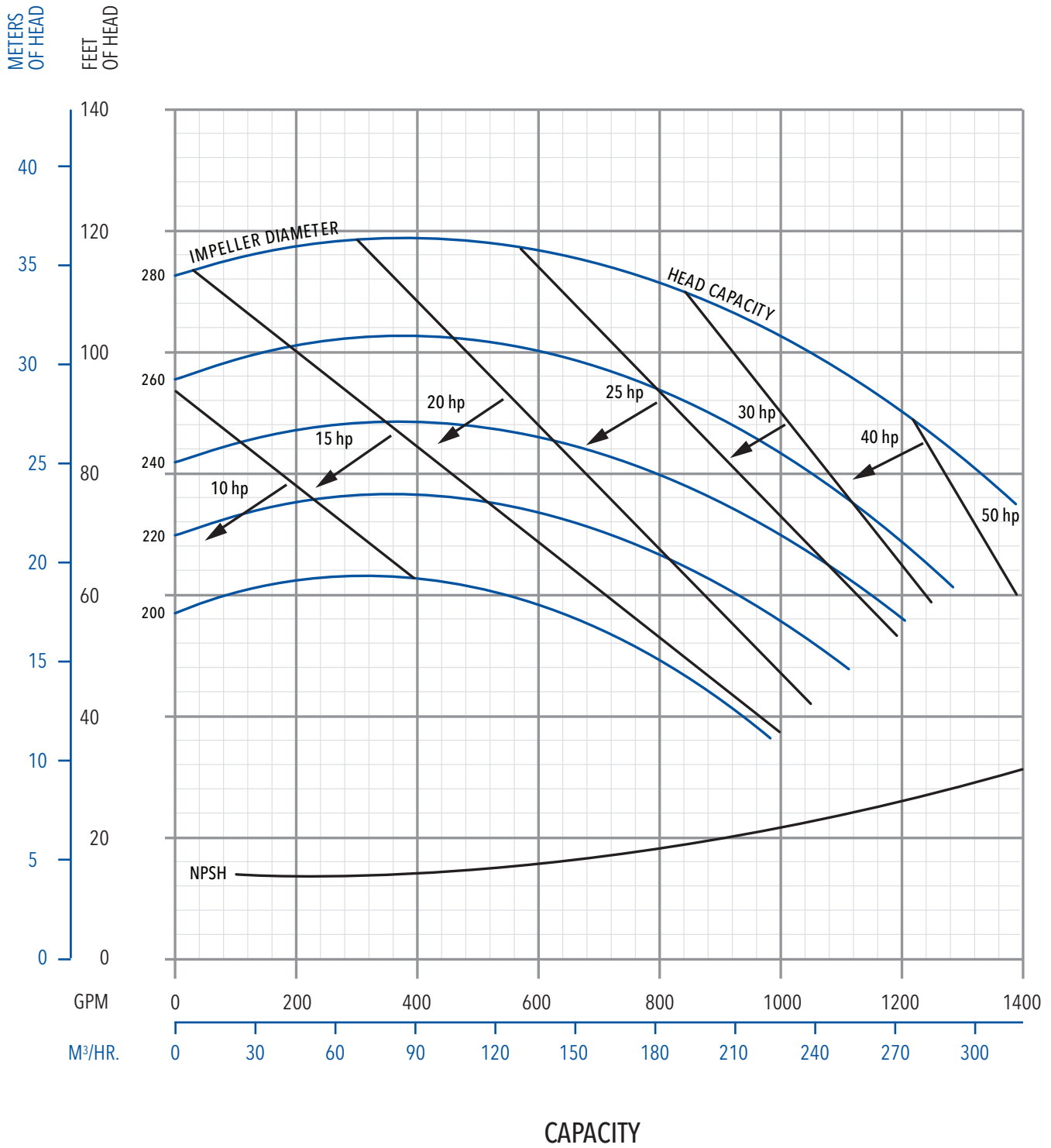

Performance curve based on tests using 70°F water and 0 psig inlet pressure. A tolerance of ± 5% applies to all figures. Actual performance may vary by application product. Please contact Fristam for different conditions.

FPR Performance Curves

Model: 4001 (1750 RPM, Inlet 6", Outlet 4")

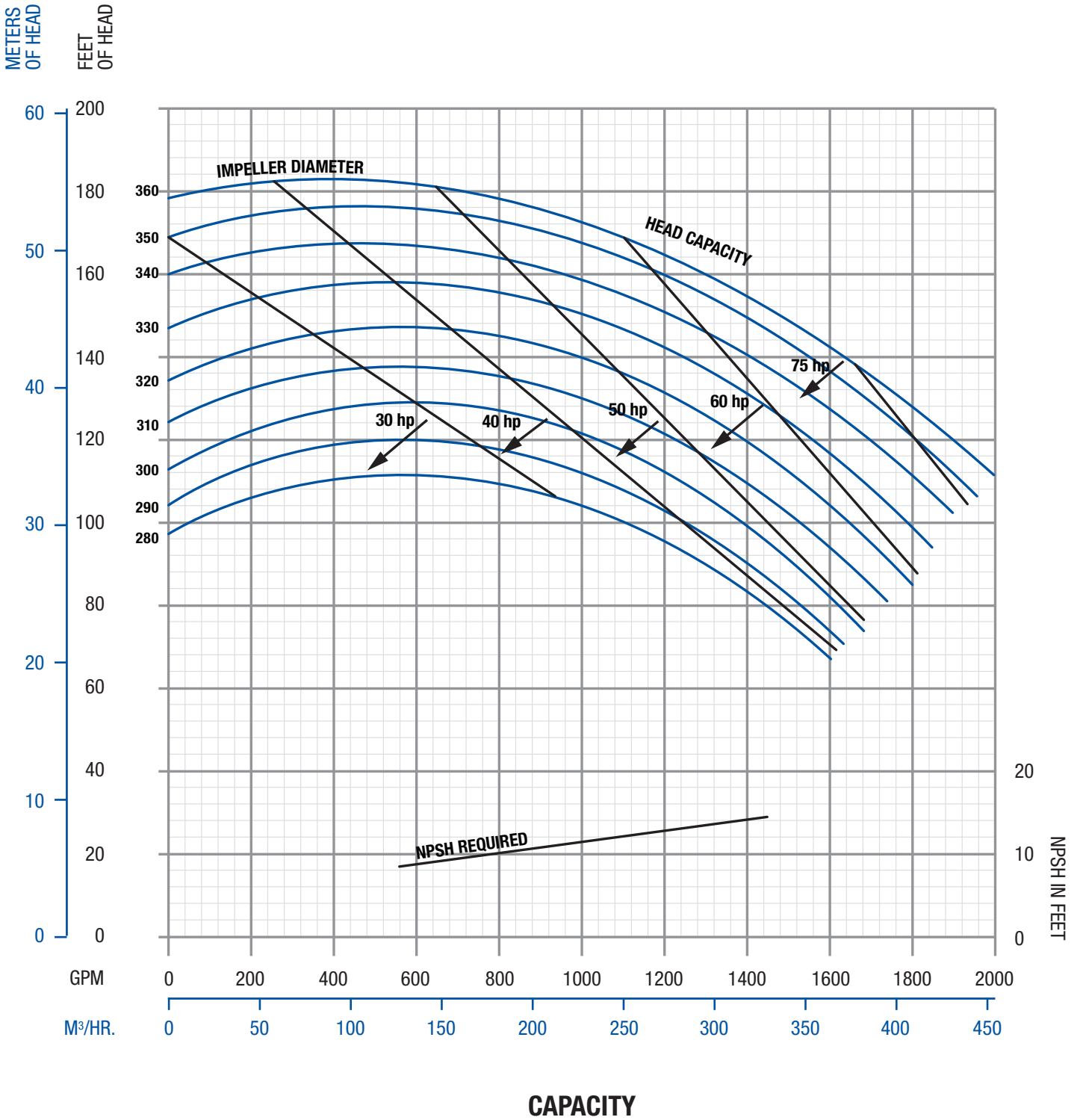

Performance curve based on tests using 70°F water and 0 psig inlet pressure. A tolerance of ± 5% applies to all figures. Actual performance may vary by application product. Please contact Fristam for different conditions.

FPR Performance Curves
 Model: 4001-X (1750 RPM, Inlet 6", Outlet 4")

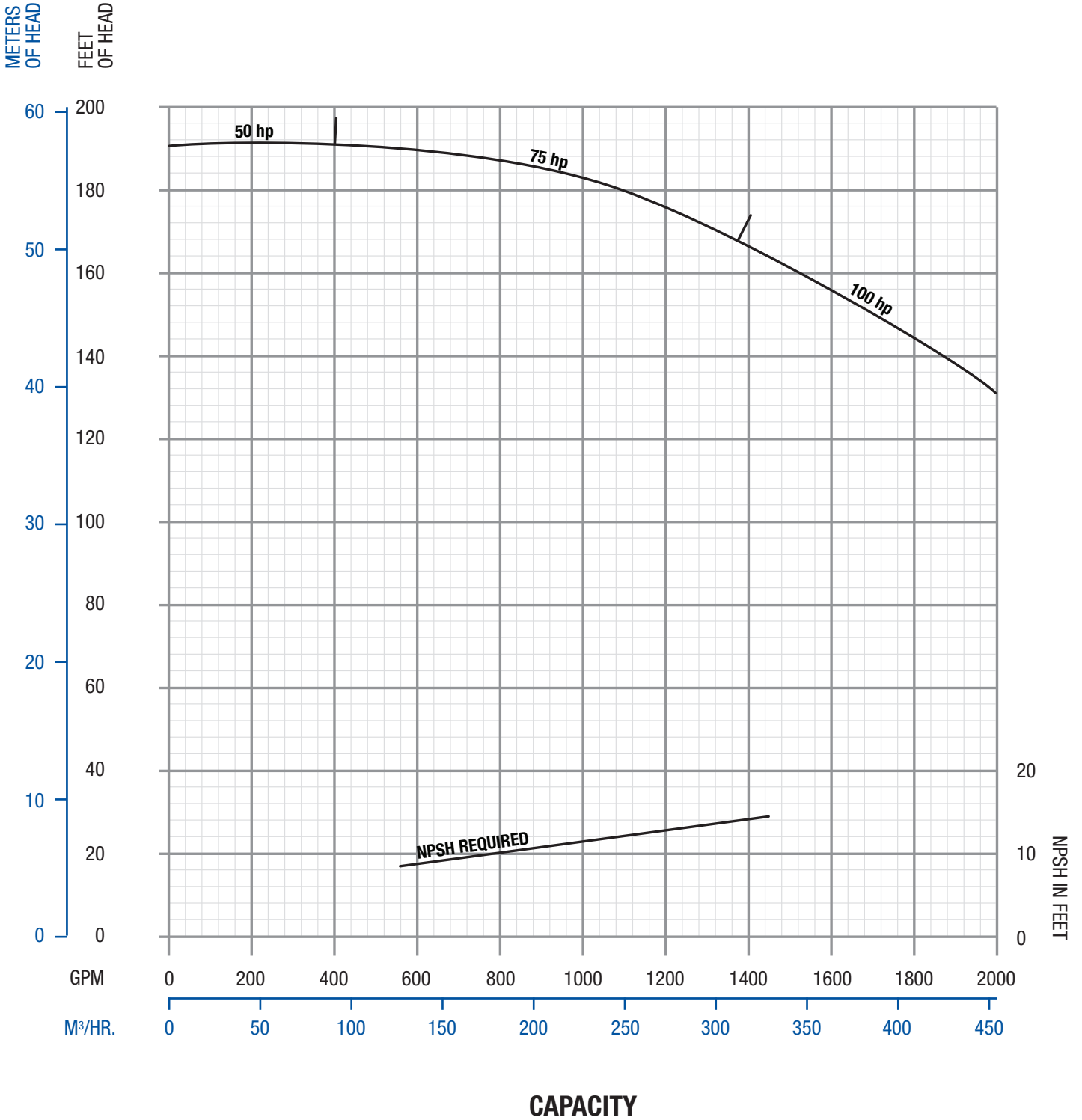

Performance curve based on tests using 70°F water and 0 psig inlet pressure. A tolerance of ± 5% applies to all figures. Actual performance may vary by application product. Please contact Fristam for different conditions.

FP/FPX/FPR Performance Curves
Models: 3500 RPM (Composite "A")
Maximum Flow: 800 GPM

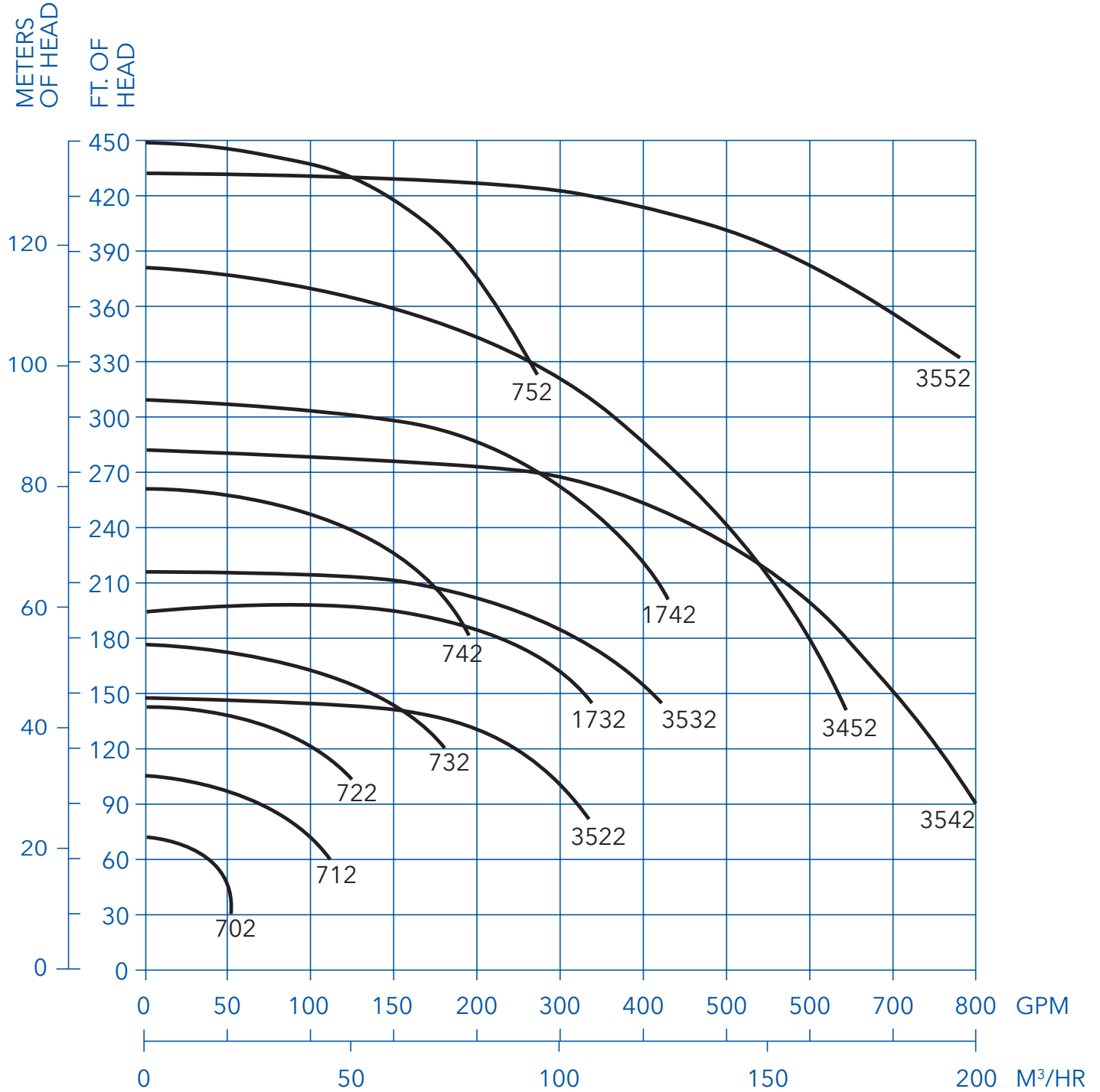

Performance curve based on tests using 70°F water and 0 psig inlet pressure. A tolerance of ± 5% applies to all figures. Actual performance may vary by application product. Please contact Fristam for different conditions.

FP/FPX/FPR Performance Curves
 Models: 3500 RPM (Composite "B")
 Maximum Flow: 1700 GPM

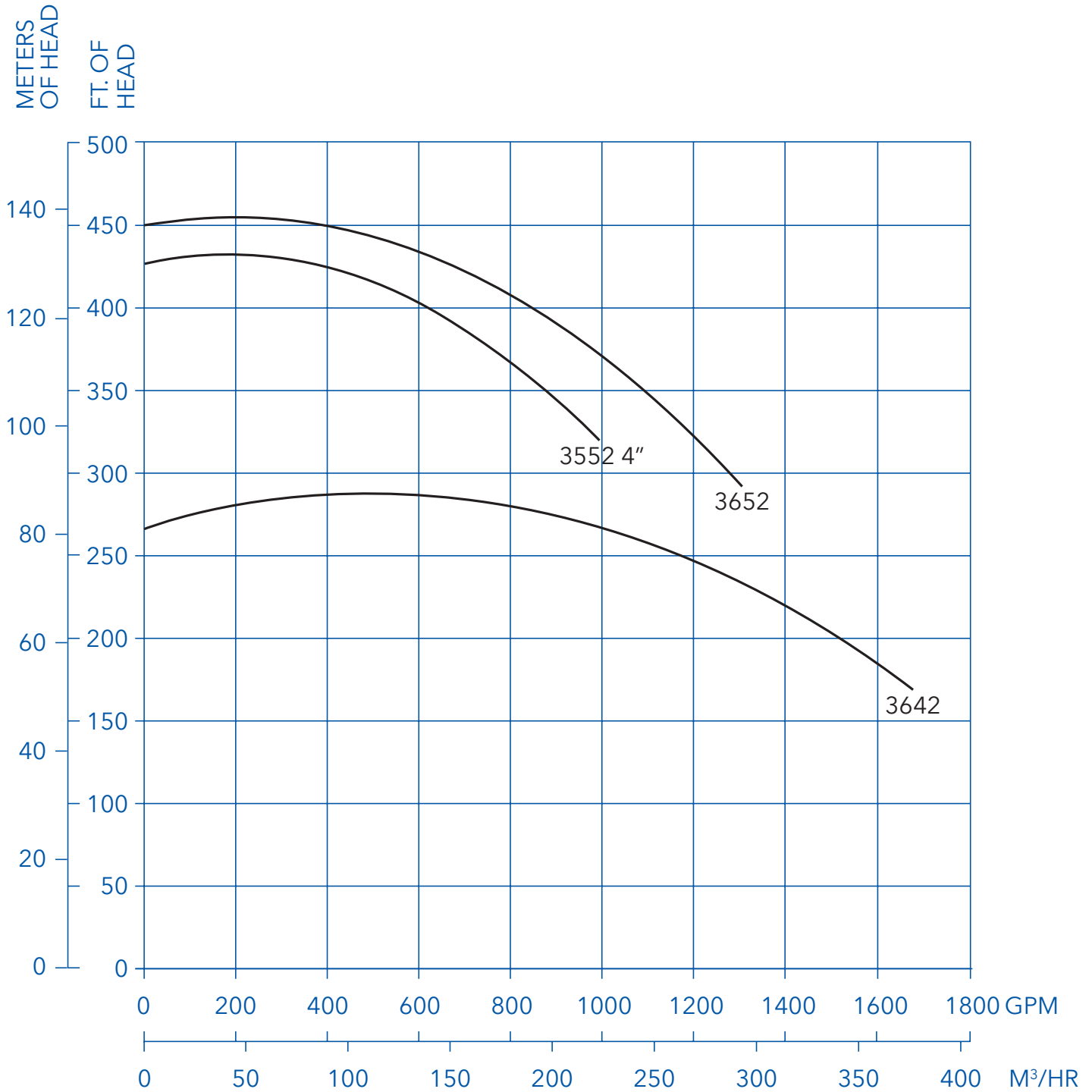

Performance curve based on tests using 70°F water and 0 psig inlet pressure. A tolerance of ± 5% applies to all figures. Actual performance may vary by application product. Please contact Fristam for different conditions.

FP/FPX/FPR Performance Curves

Model: 702 (3500 RPM, Inlet 1.5", Outlet 1.5")

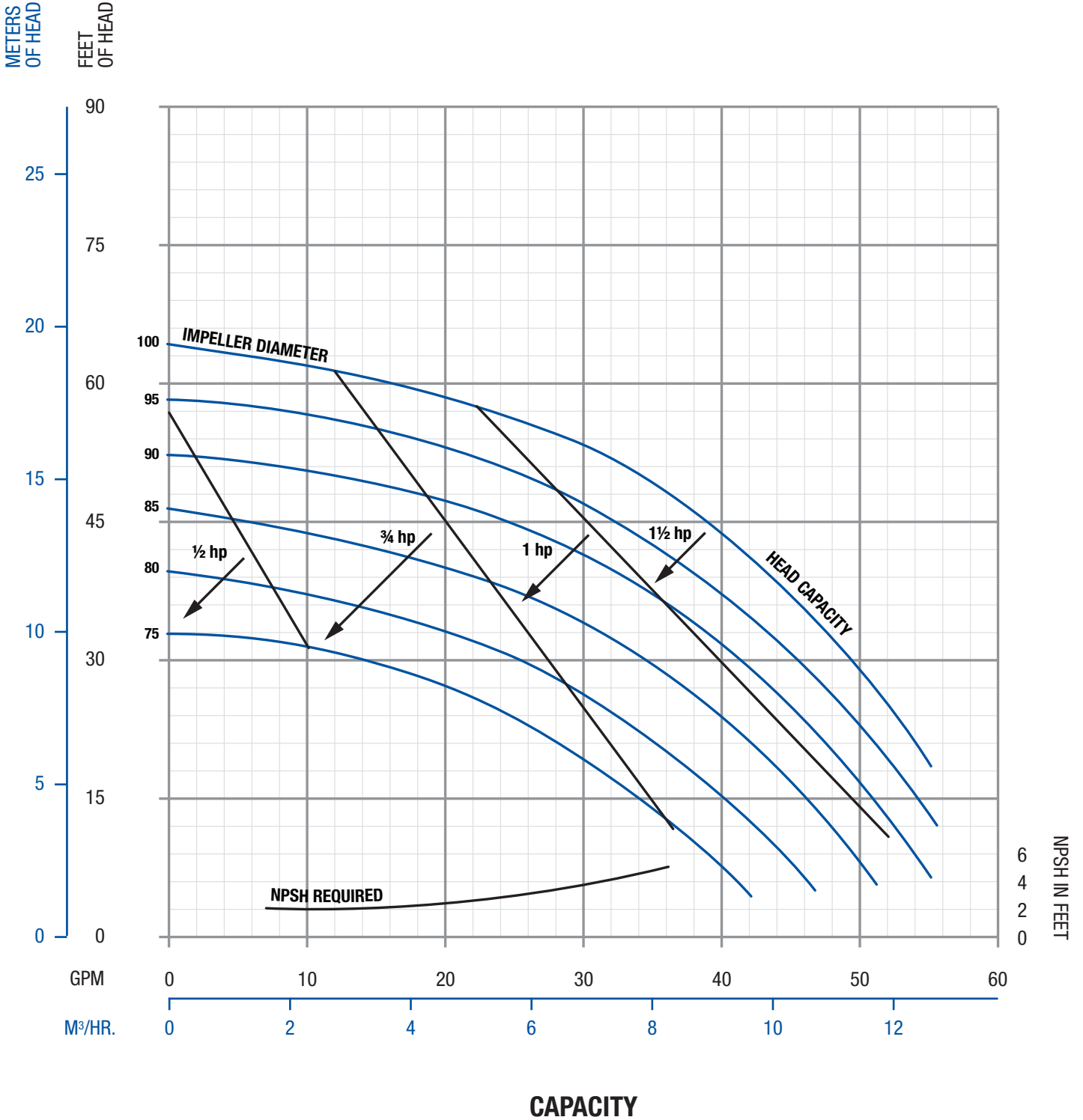

Performance curve based on tests using 70°F water and 0 psig inlet pressure. A tolerance of ± 5% applies to all figures. Actual performance may vary by application product. Please contact Fristam for different conditions.

FP/FPX/FPR Performance Curves
Model: 712 (3500 RPM, Inlet 2", Outlet 1.5")

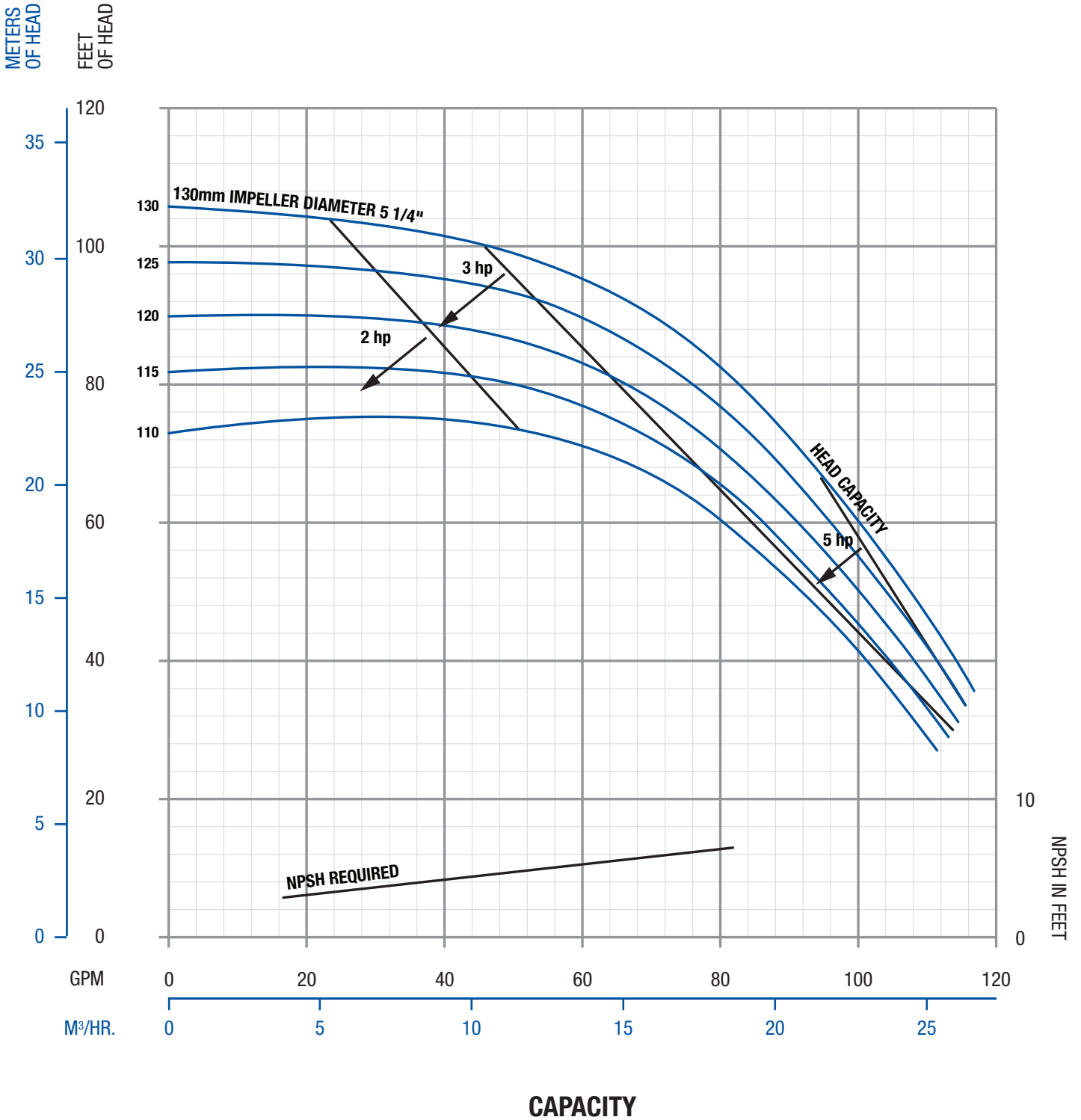

Performance curve based on tests using 70°F water and 0 psig inlet pressure. A tolerance of ± 5% applies to all figures. Actual performance may vary by application product. Please contact Fristam for different conditions.

FP/FPX/FPR Performance Curves

Model: 722 (3500 RPM, Inlet 2", Outlet 1.5")

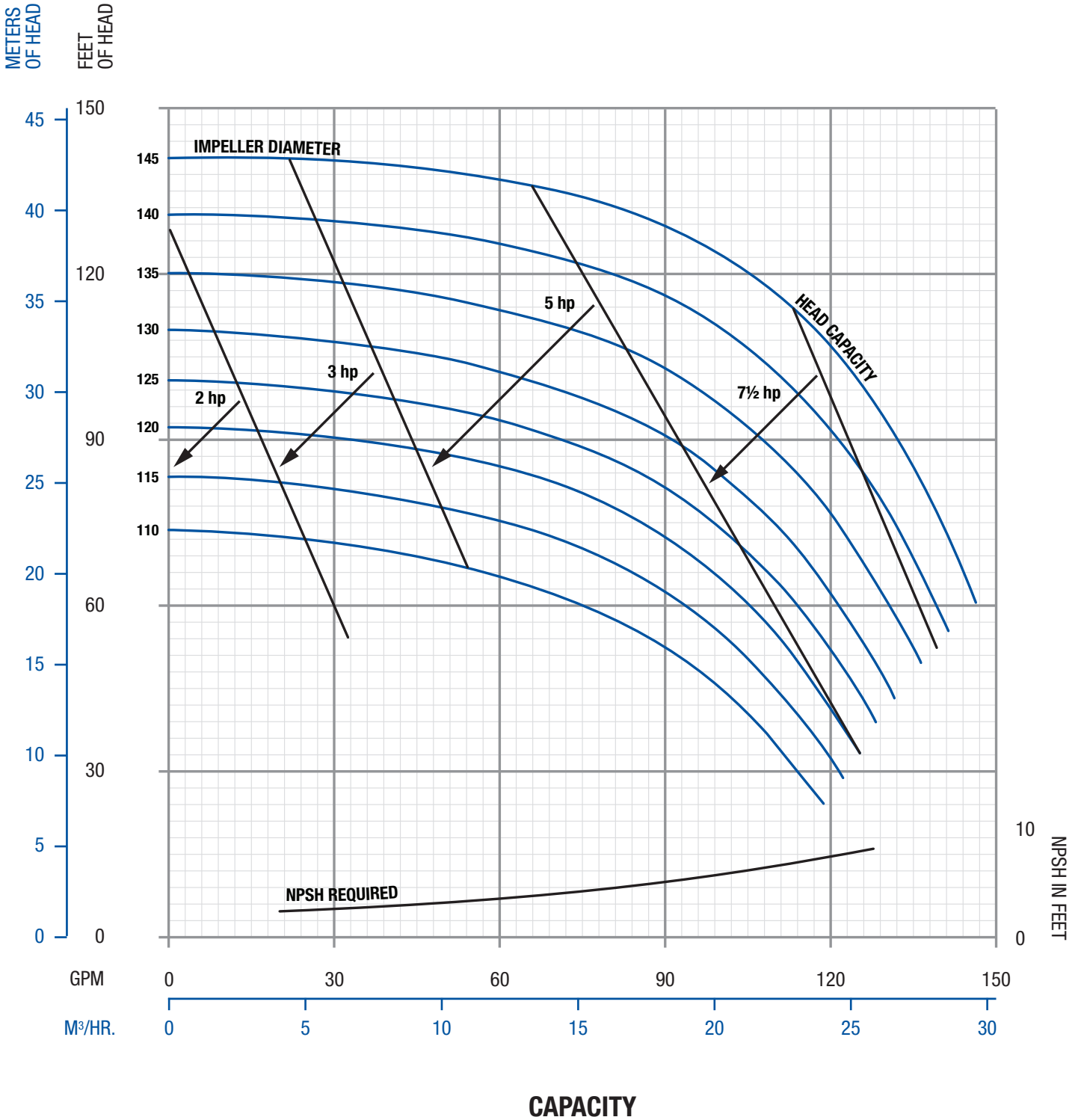

Performance curve based on tests using 70°F water and 0 psig inlet pressure. A tolerance of ± 5% applies to all figures. Actual performance may vary by application product. Please contact Fristam for different conditions.

FP/FPX/FPR Performance Curves

Model: 3522 (3500 RPM, Inlet 2.5", Outlet 2")

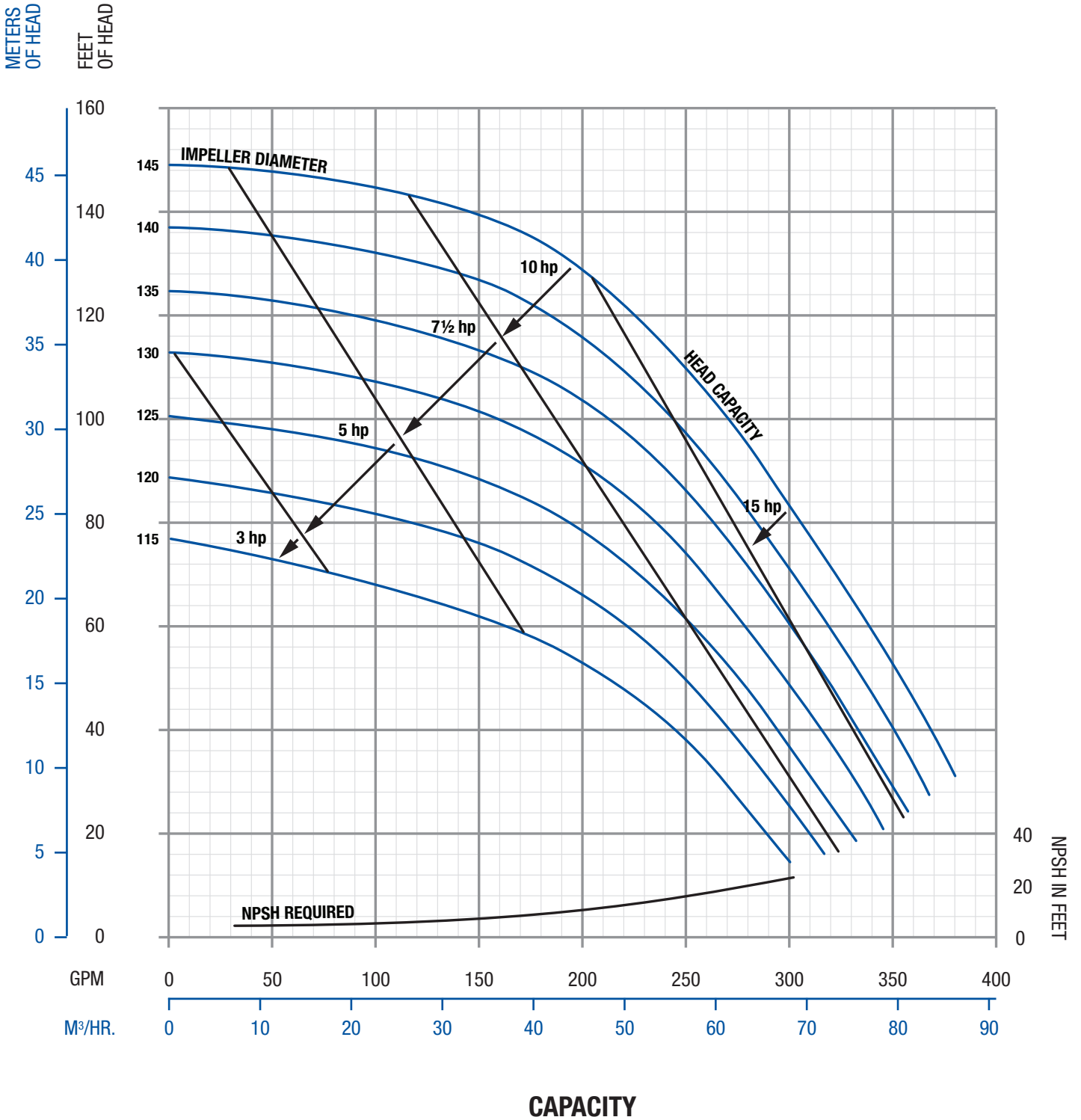

Performance curve based on tests using 70°F water and 0 psig inlet pressure. A tolerance of ± 5% applies to all figures. Actual performance may vary by application product. Please contact Fristam for different conditions.

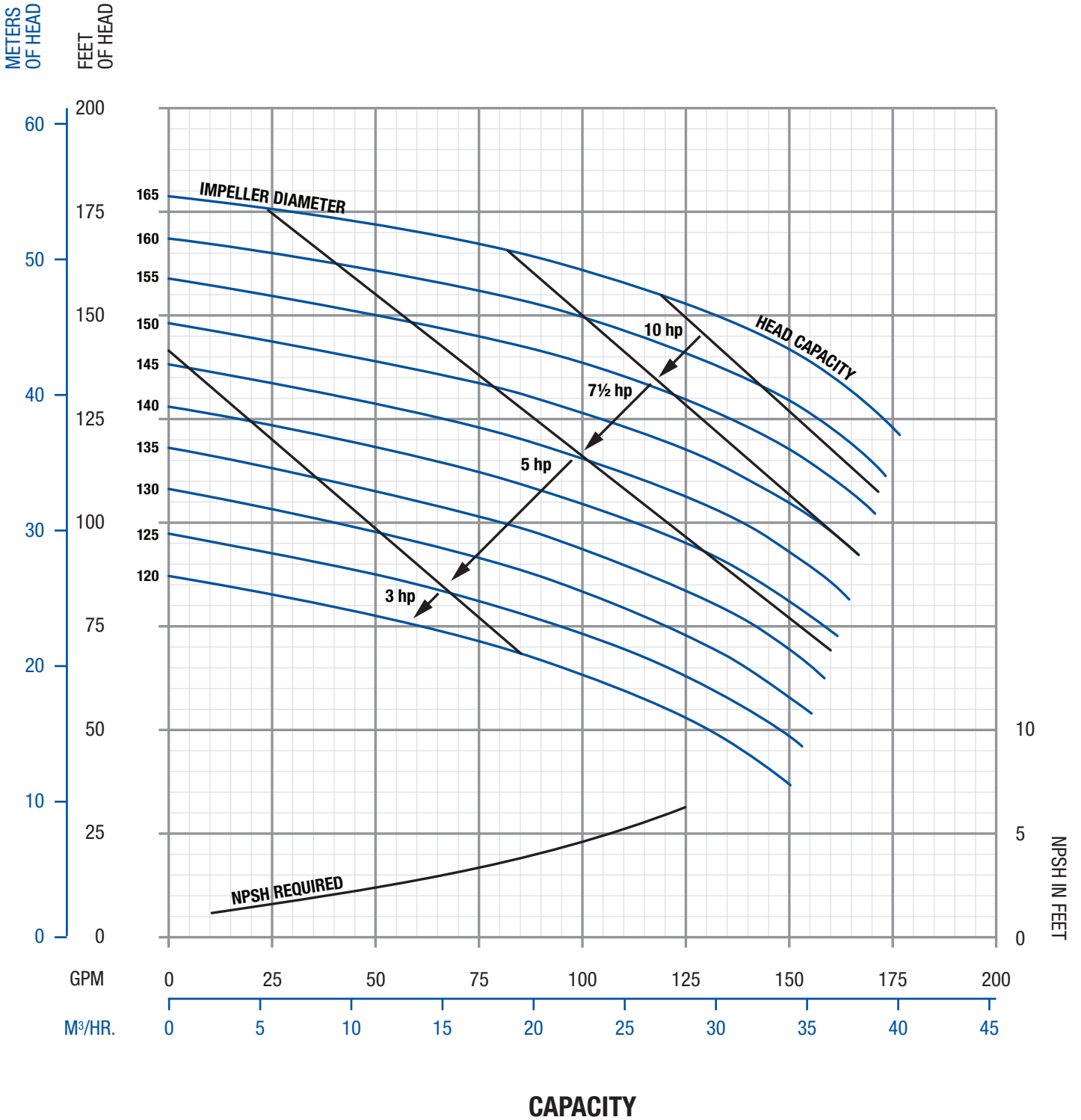

Performance curve based on tests using 70°F water and 0 psig inlet pressure. A tolerance of ± 5% applies to all figures. Actual performance may vary by application product. Please contact Fristam for different conditions.

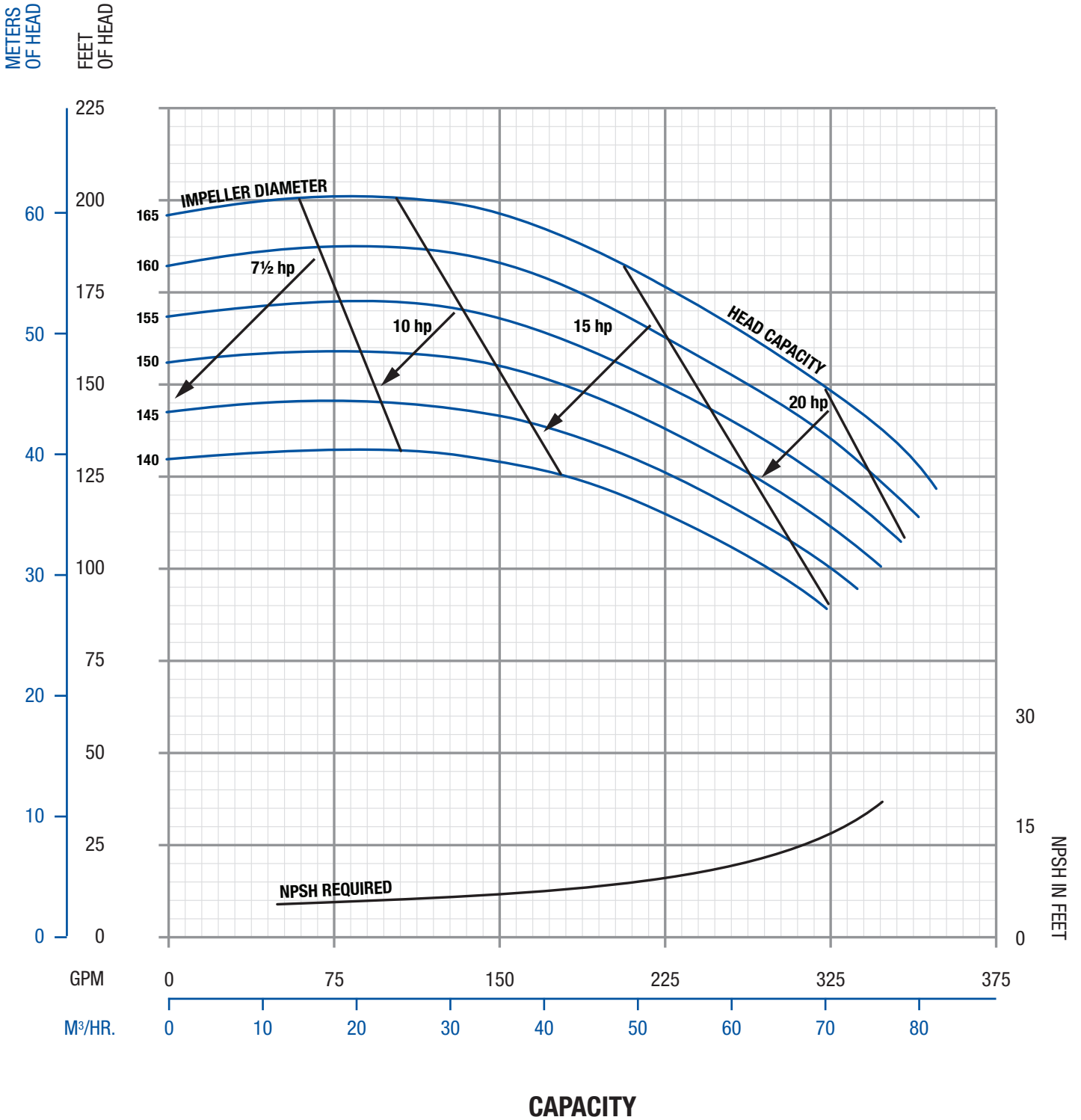

Performance curve based on tests using 70°F water and 0 psig inlet pressure. A tolerance of ± 5% applies to all figures. Actual performance may vary by application product. Please contact Fristam for different conditions.

FP/FPX/FPR Performance Curves

Model: 3532 (3500 RPM, Inlet 2.5", Outlet 2")

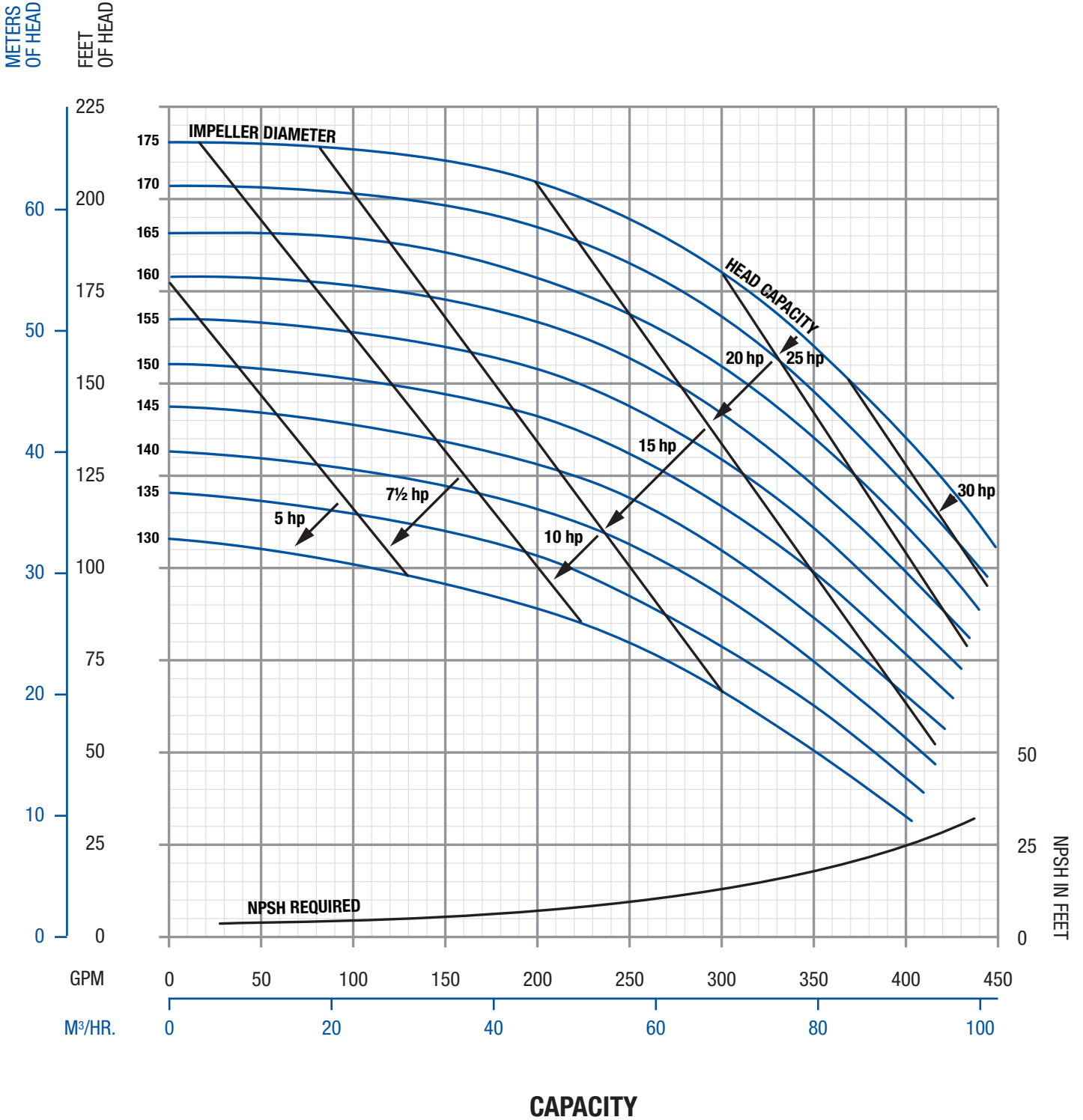

Performance curve based on tests using 70°F water and 0 psig inlet pressure. A tolerance of ± 5% applies to all figures. Actual performance may vary by application product. Please contact Fristam for different conditions.

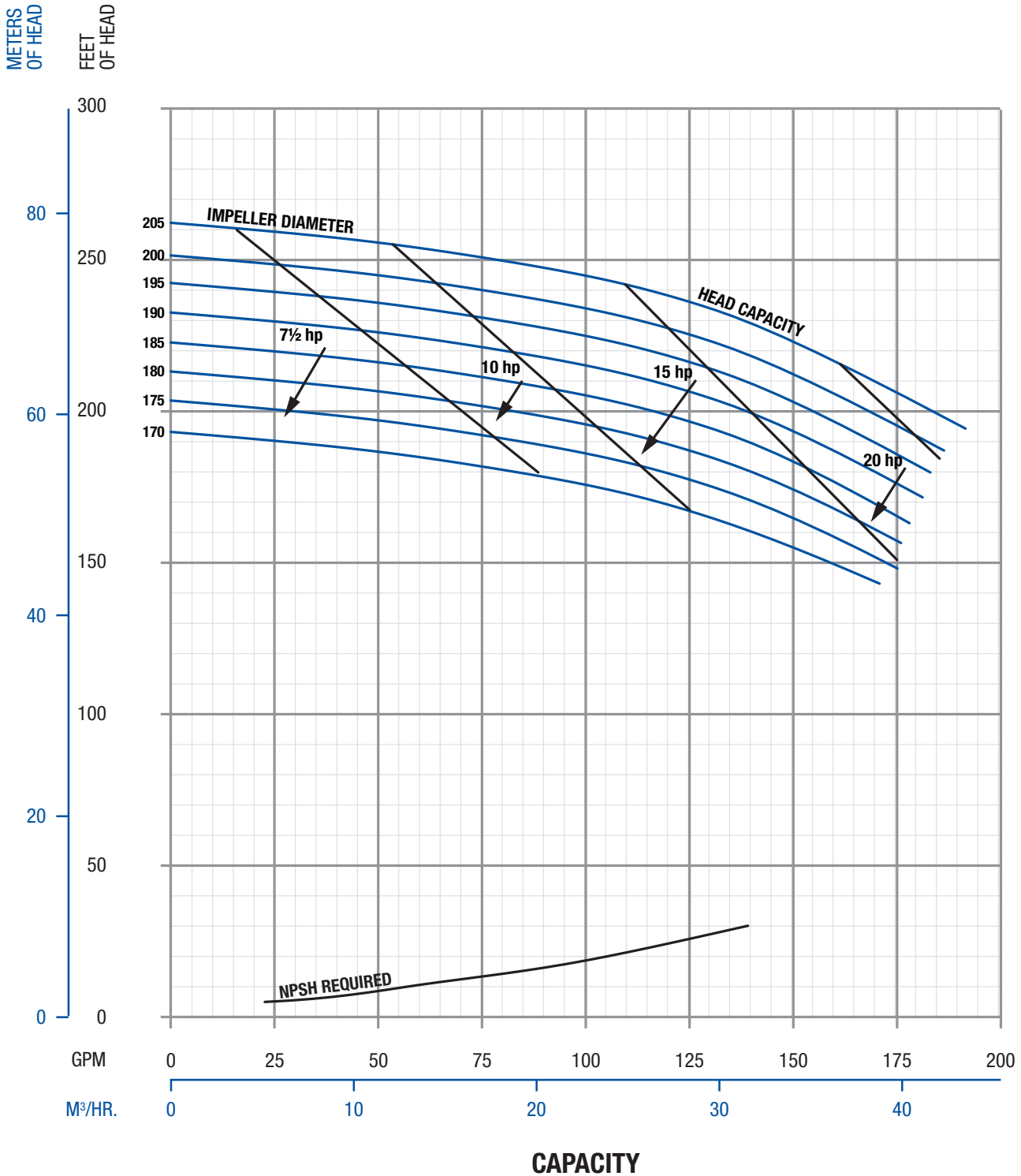

Performance curve based on tests using 70°F water and 0 psig inlet pressure. A tolerance of ± 5% applies to all figures. Actual performance may vary by application product. Please contact Fristam for different conditions.

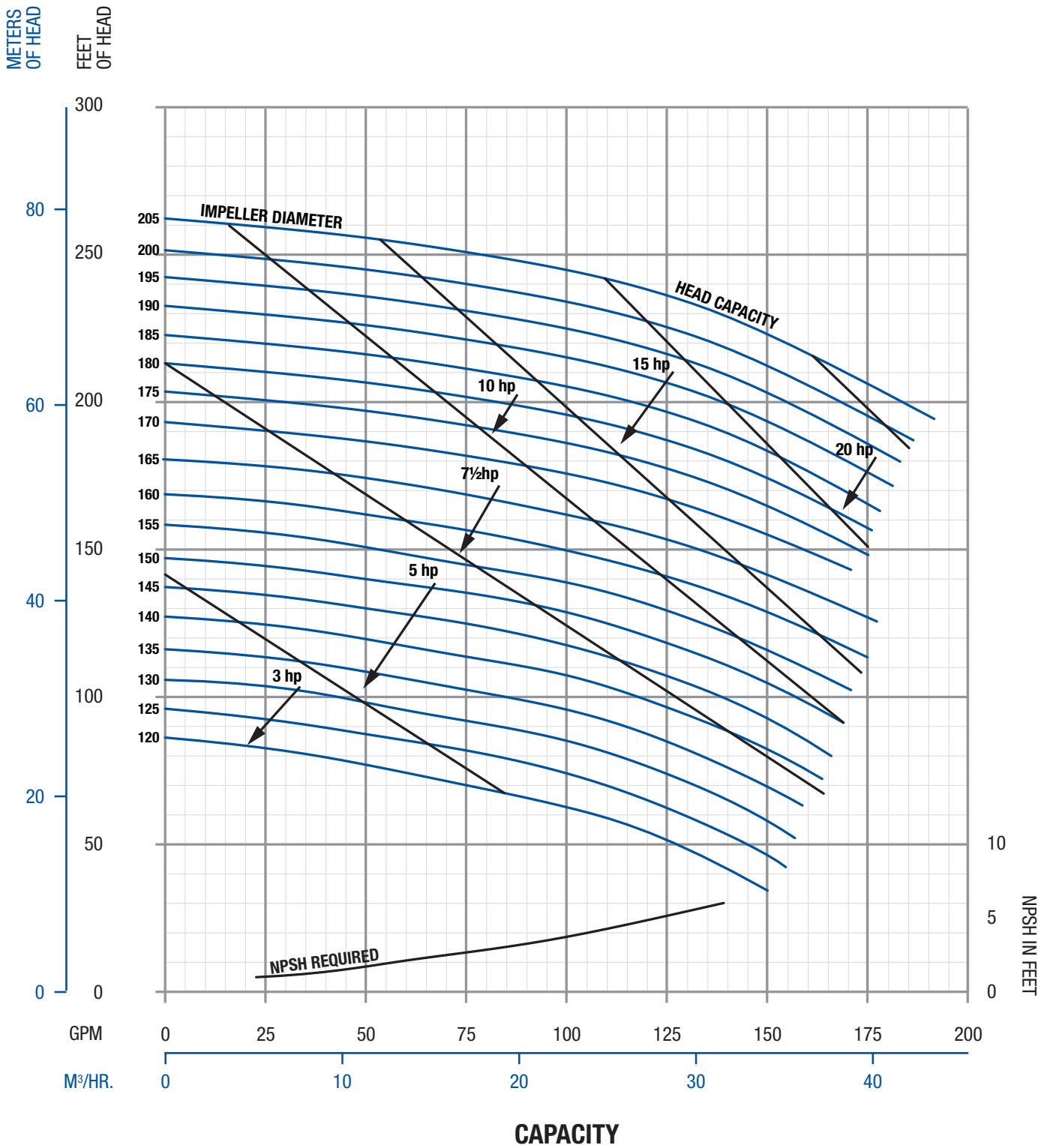

Performance curve based on tests using 70°F water and 0 psig inlet pressure. A tolerance of ± 5% applies to all figures. Actual performance may vary by application product. Please contact Fristam for different conditions.

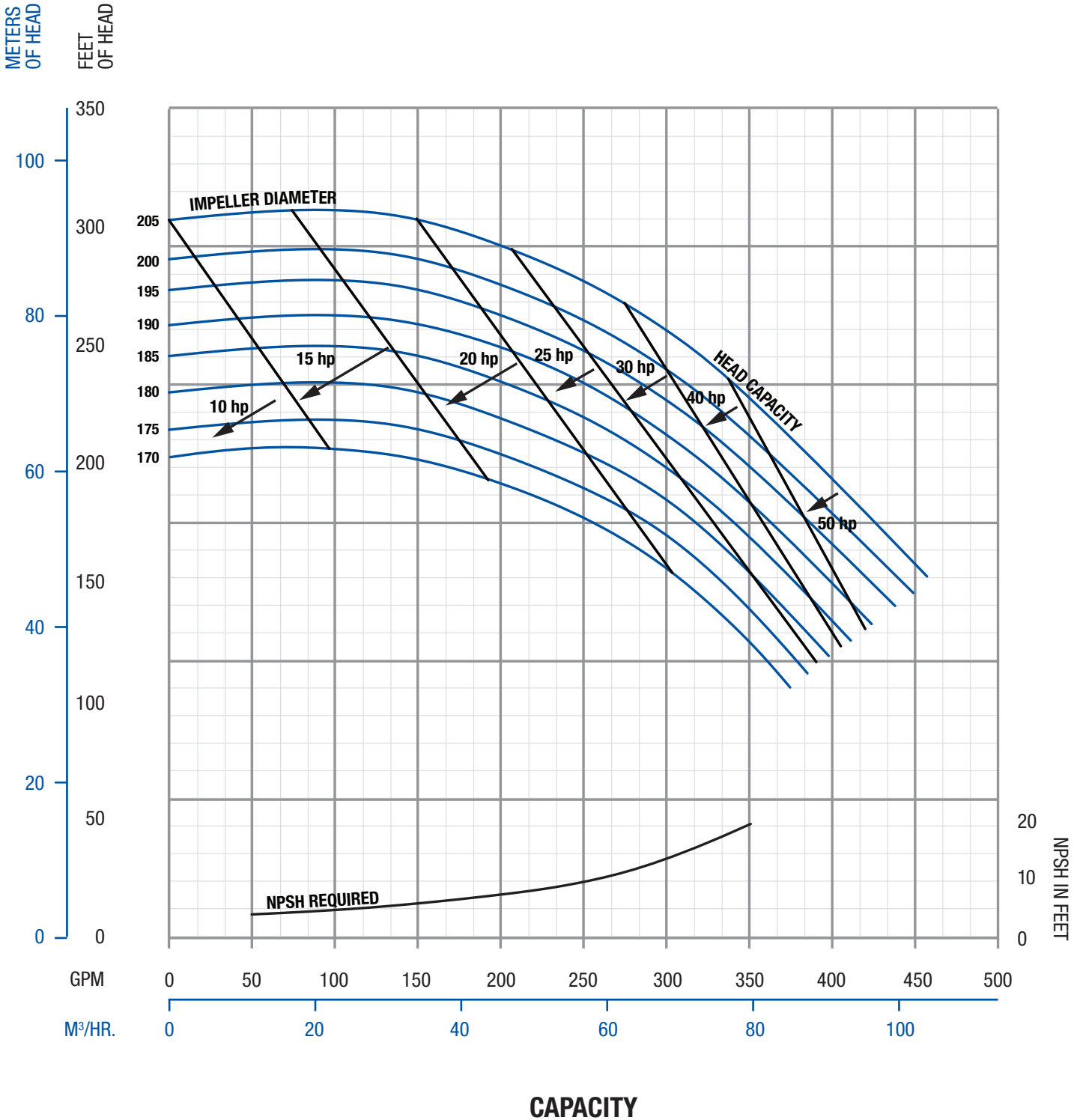

Performance curve based on tests using 70°F water and 0 psig inlet pressure. A tolerance of ± 5% applies to all figures. Actual performance may vary by application product. Please contact Fristam for different conditions.

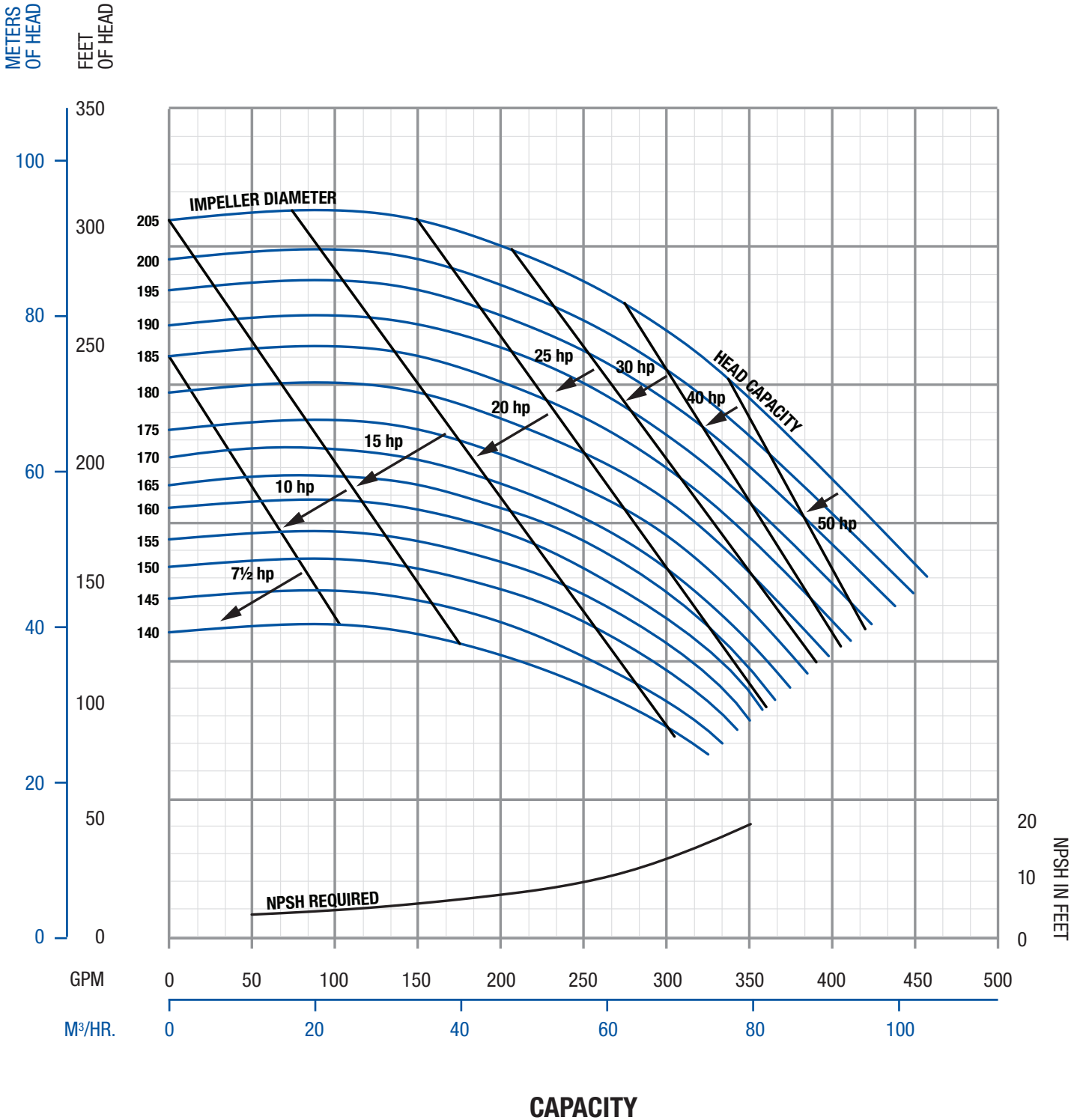

Performance curve based on tests using 70°F water and 0 psig inlet pressure. A tolerance of ± 5% applies to all figures. Actual performance may vary by application product. Please contact Fristam for different conditions.

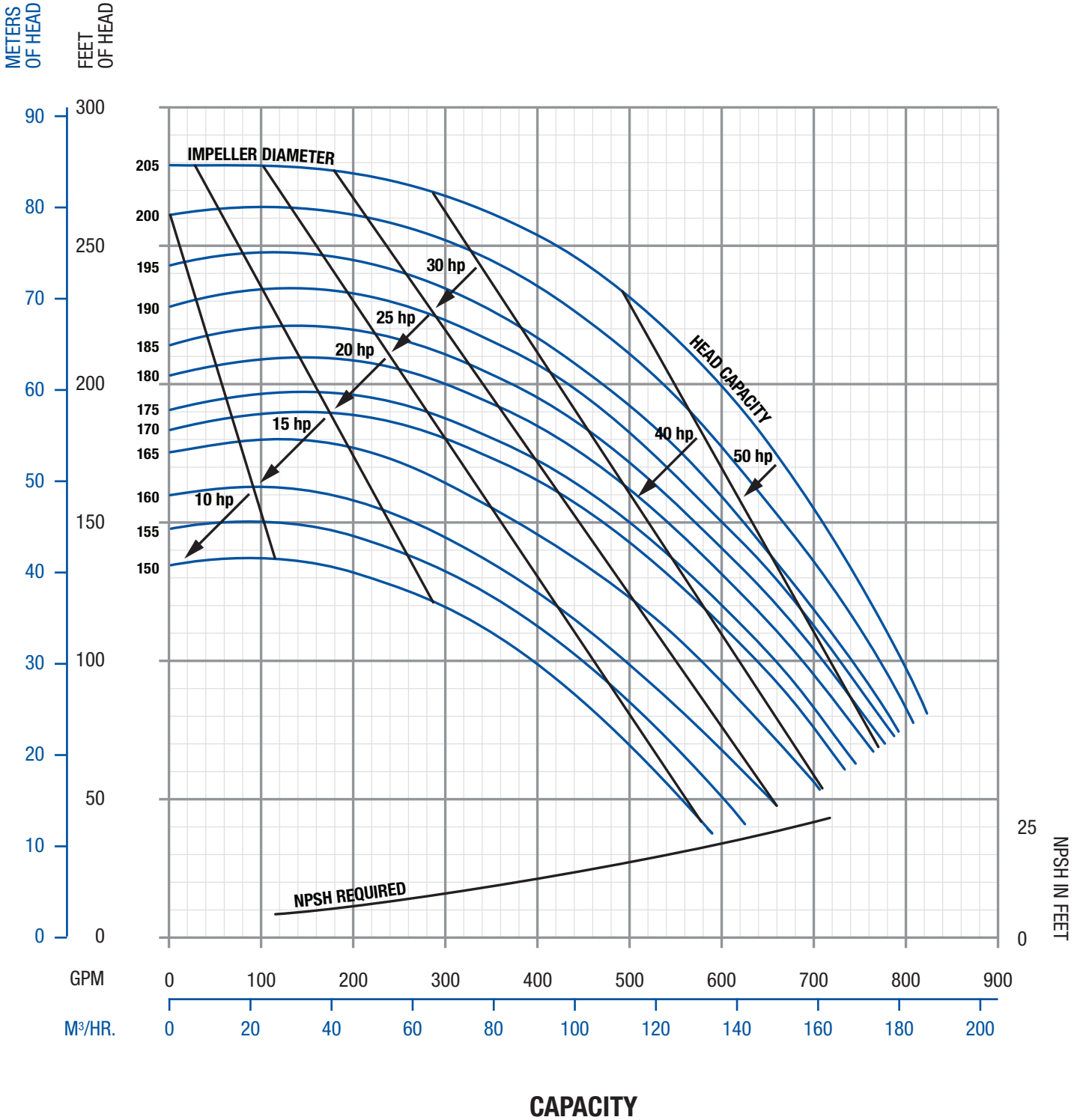

Performance curve based on tests using 70°F water and 0 psig inlet pressure. A tolerance of ± 5% applies to all figures. Actual performance may vary by application product. Please contact Fristam for different conditions.

FPR Performance Curves

Model: 752 (3500 RPM, Inlet 3", Outlet 2")

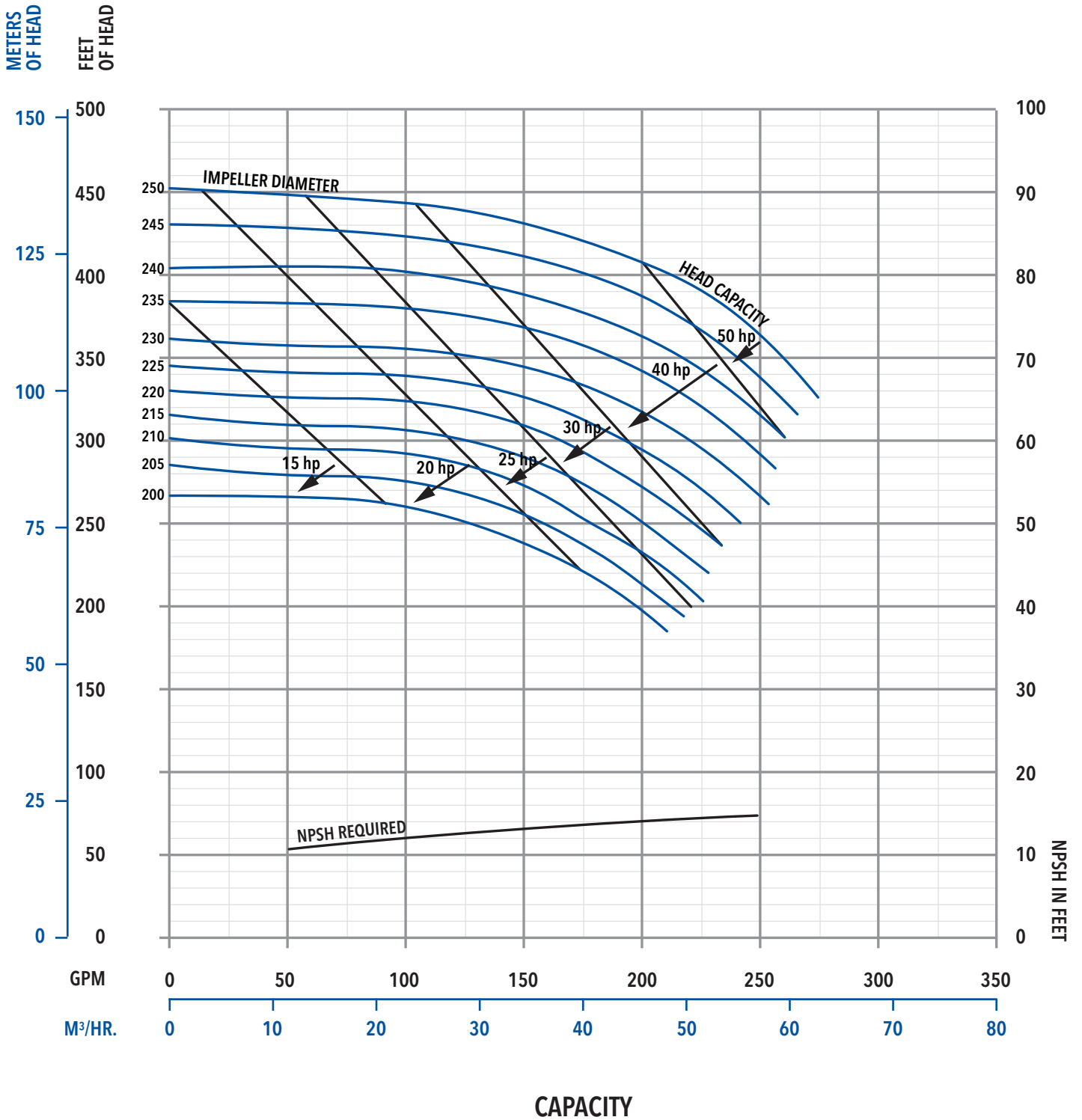

Performance curve based on tests using 70°F water and 0 psig inlet pressure. A tolerance of ± 5% applies to all figures. Actual performance may vary by application product. Please contact Fristam for different conditions.

FP/FPX/FPR Performance Curves

Model: 3452 (3500 RPM, Inlet 3", Outlet 2")

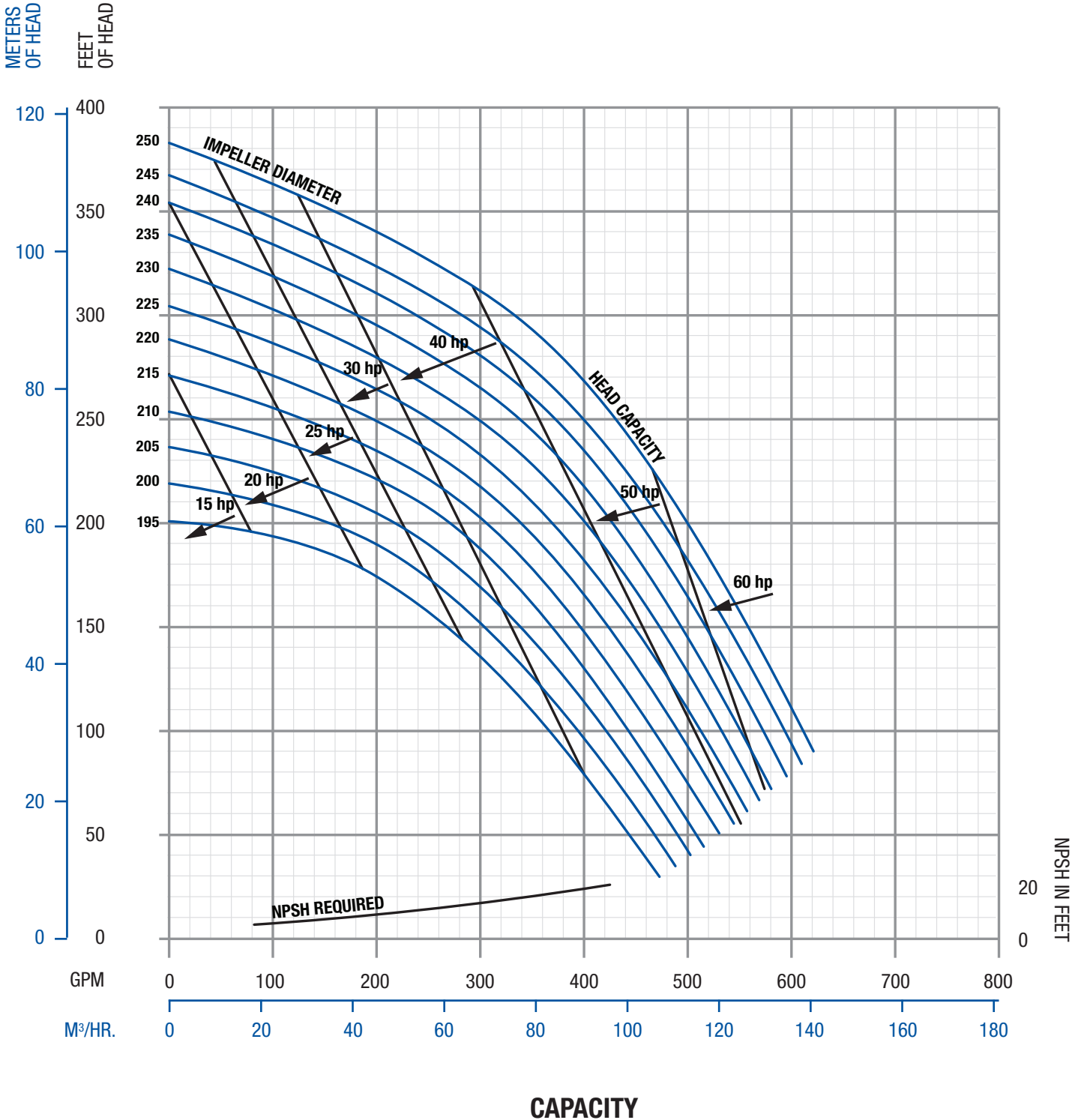

Performance curve based on tests using 70°F water and 0 psig inlet pressure. A tolerance of ± 5% applies to all figures. Actual performance may vary by application product. Please contact Fristam for different conditions.

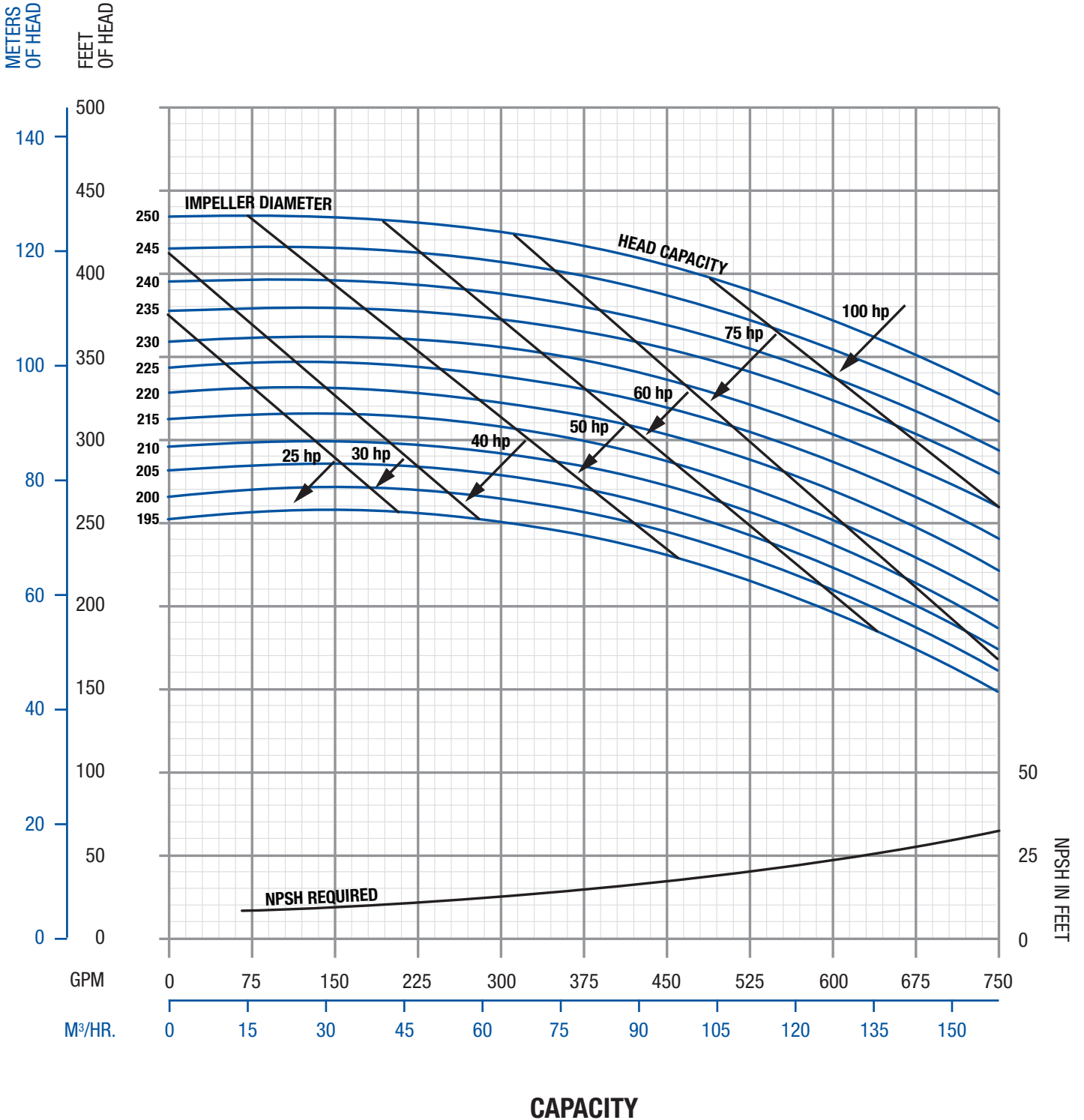

Performance curve based on tests using 70°F water and 0 psig inlet pressure. A tolerance of ± 5% applies to all figures. Actual performance may vary by application product. Please contact Fristam for different conditions.

FP/FPX/FPR Performance Curves

Model: 3552-4" (3500 RPM, Inlet 4", Outlet 2.5")

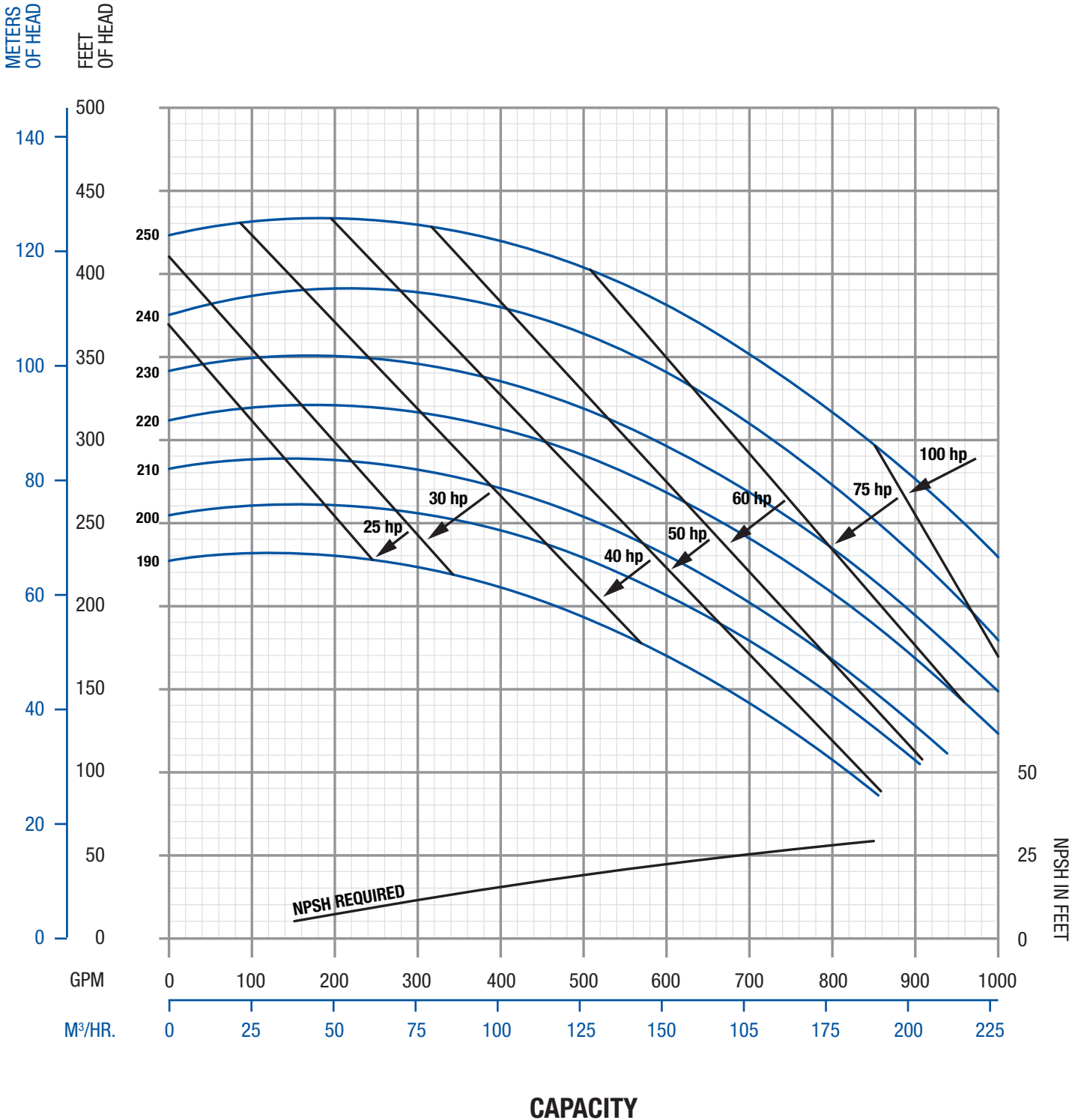

Performance curve based on tests using 70°F water and 0 psig inlet pressure. A tolerance of ± 5% applies to all figures. Actual performance may vary by application product. Please contact Fristam for different conditions.

FPR Performance Curves

Model: 3642 (3500 RPM, Inlet 4", Outlet 4")

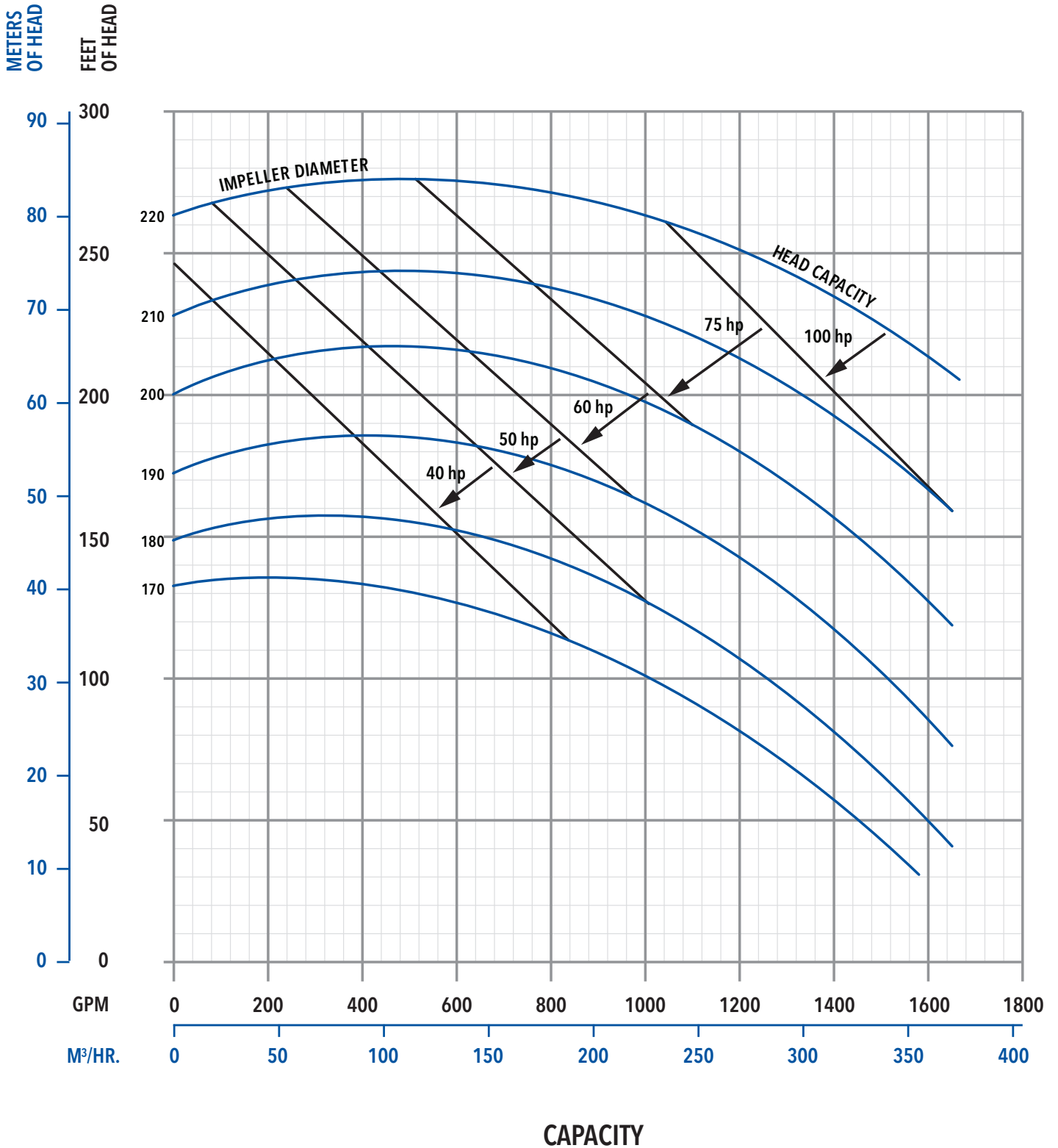

Performance curve based on tests using 70°F water and 0 psig inlet pressure. A tolerance of ± 5% applies to all figures. Actual performance may vary by application product. Please contact Fristam for different conditions.

FPR Performance Curves

Model: 3652 (3500 RPM, Inlet 4", Outlet 2.5")

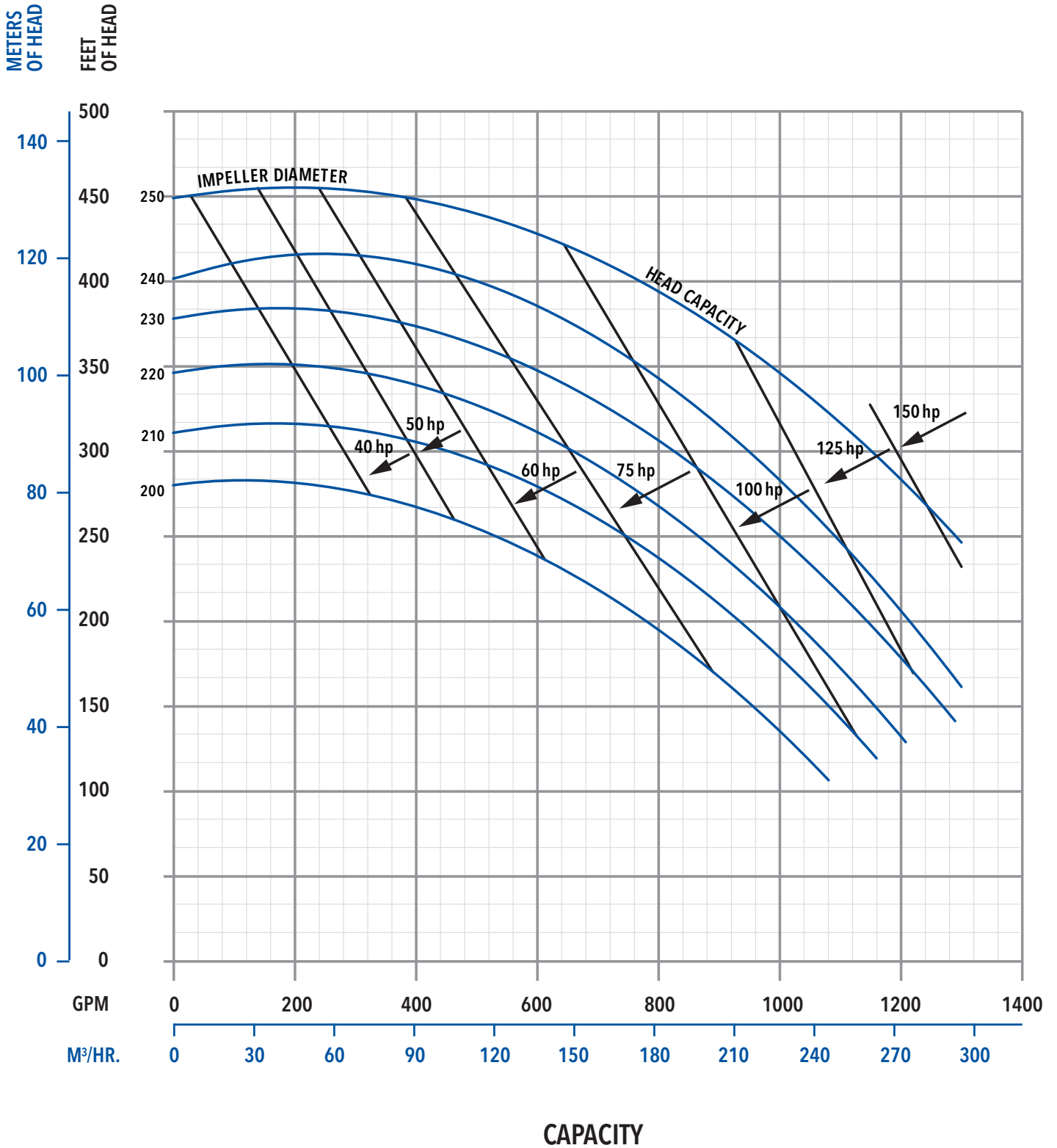

Performance curve based on tests using 70°F water and 0 psig inlet pressure. A tolerance of ± 5% applies to all figures. Actual performance may vary by application product. Please contact Fristam for different conditions.

FP Single Flange Dimensional Drawing

All pump dimensions are in millimeters (inches). Dimensions are based on clamp fittings. Motor dimensions may vary by manufacturer.

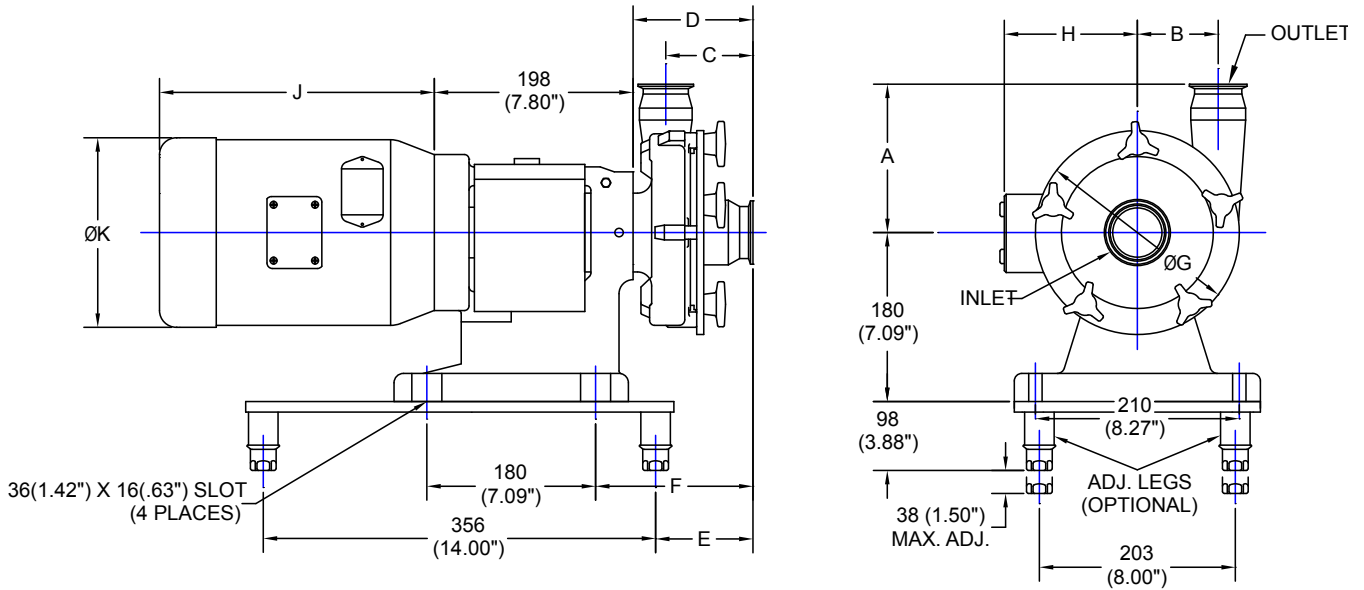

1265000384 REV-

| PUMP MODEL | INLET | OUTLET | DIMENSIONS IN MILLIMETERS (INCHES) | | | | | | |
|-----------------------|-------|--------|------------------------------------|-----------------|------------------|------------------|------------------|------------------|-----------------|
| | | | A | B | C | D | E | F | ØG |
| FP 701 / 702 | 1.5" | 1.5" | 108 (4.25") | 44.5 (1.75") | 108.5 (4.27") | 146.5 (5.77") | 154.5 (6.08") | 186.5 (7.34") | 150 (5.90") |
| FP 711 / 712 | 2" | 1.5" | 144 (5.67") | 58 (2.28") | 113 (4.45") | 150 (5.90") | 158 (6.22") | 190 (7.48") | 185 (7.28") |
| FP 721 / 731 / 722 | 2" | 1.5" | 170 (6.69") | 79 (3.11") | 113 (4.45") | 150 (5.90") | 158 (6.22") | 190 (7.48") | 230 (9.06") |
| FP 741 / 732 / 742 | 2.5" | 2" | 195 (7.68") | 96 (3.78") | 101 (3.98") | 141 (5.55") | 149 (5.87") | 181 (7.13") | 270 (10.63") |
| FP 1741 / 1732 / 1742 | 2.5" | 2" | 200 (7.87") | 91 (3.58") | 104 (4.09") | 150.5 (5.93") | 158.5 (6.24") | 190.5 (7.50") | 270 (10.63") |
| FP 3521 / 3522 | 2.5" | 2" | 190 (7.48") | 80 (3.15") | 118 (4.64") | 162 (6.38") | 170 (6.69") | 202 (7.95") | 230 (9.06") |
| FP 3531 / 3532 | 2.5" | 2" | 191 (7.52") | 95 (3.74") | 115.5 (4.55") | 162 (6.38") | 170 (6.69") | 202 (7.95") | 260 (10.24") |
| FP 3541 / 3542 | 3" | 2.5" | 211 (8.31") | 115 (4.53") | 118 (4.64") | 162 (6.38") | 170 (6.69") | 202 (7.95") | 290 (11.42") |
| FP 3451 / 3452 | 3" | 2" | 211 (8.31") | 140 (5.51") | 114 (4.49") | 158 (6.22") | 166 (6.54") | 198 (7.80") | 350 (13.78") |

| MOTOR HP | | MOTOR FRAME | DIMENSIONS IN MILLIMETERS (INCHES) | | |
|----------|----------|-------------|------------------------------------|-----------------|-----------------|
| 1750 RPM | 3500 RPM | | H | J | ØK |
| | 0.5 HP | 56C | 115 (4.53") | 236 (9.29") | 157 (6.19") |
| 0.75 HP | 0.75 HP | 56C | 115 (4.53") | 236 (9.29") | 157 (6.19") |
| | 1 HP | 56C | 115 (4.53") | 236 (9.29") | 157 (6.19") |
| 1 HP | 1.5 HP | 143TC | 115 (4.53") | 252 (9.94") | 157 (6.19") |
| 1.5 HP | | 145TC | 133 (5.22") | 259 (10.19") | 183 (7.19") |
| 2 HP | 2 HP | 145TC | 133 (5.22") | 284 (11.19") | 183 (7.19") |
| | 3 HP | 145TC | 133 (5.22") | 284 (11.19") | 183 (7.19") |
| 3 HP | | 182TC | 133 (5.23") | 313 (12.31") | 216 (8.50") |
| 5 HP | 5 HP | 184TC | 152 (6.00") | 348 (13.68") | 216 (8.50") |
| | 7.5 HP | 184TC | 152 (6.00") | 386 (15.18") | 216 (8.50") |
| 7.5 HP | 7.5 HP | 213TC | 189 (7.46") | 388 (15.27") | 263 (10.34") |
| | 10 HP | 215TC | 189 (7.46") | 388 (15.27") | 263 (10.34") |
| 10 HP | 15 HP | 215TC | 189 (7.46") | 416 (16.40") | 263 (10.34") |

1265000385 REV-

FP Double Flange Dimensional Drawing [Frame Sizes 182TC-286T(S)C]

All pump dimensions are in millimeters (inches). Dimensions are based on clamp fittings. Motor dimensions may vary by manufacturer.

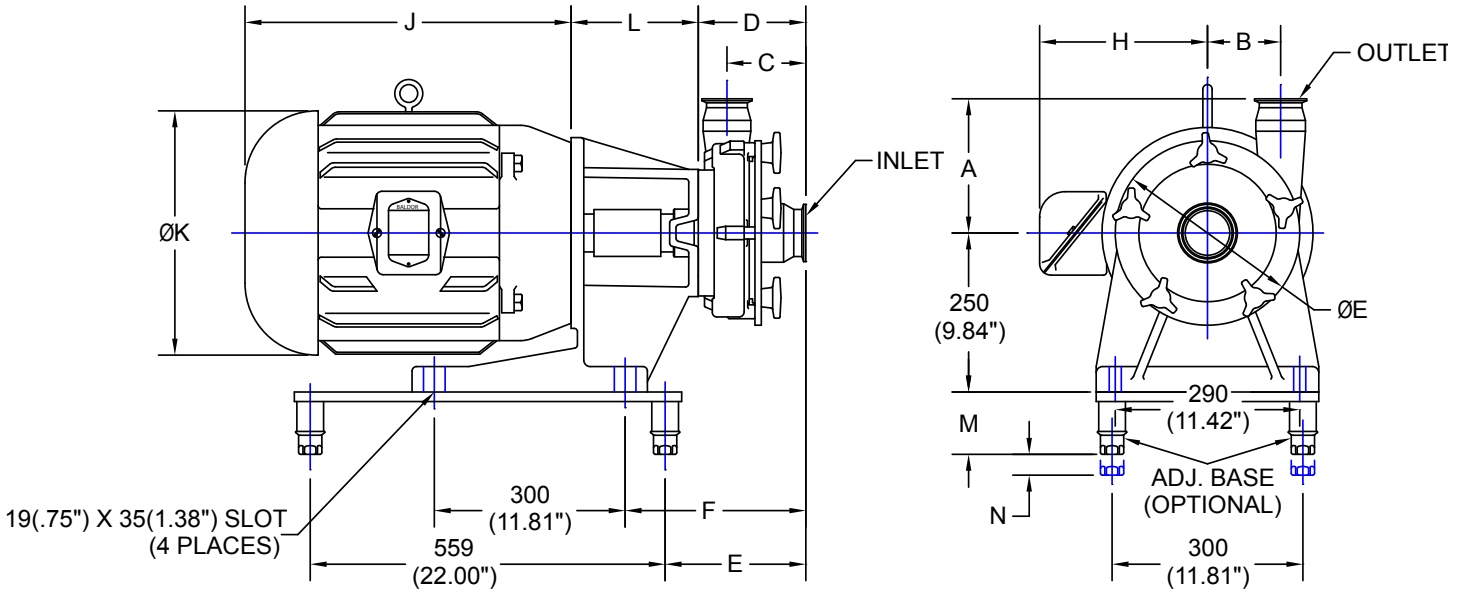

1265000386 REV-

| PUMP MODEL | INLET | OUTLET | DIMENSIONS IN MILLIMETERS (INCHES) | | | | | | |
|----------------|-------|--------|------------------------------------|----------------|------------------|------------------|------------------|-------------------|-----------------|
| | | | A | B | C | D | E | F | ØE |
| FP 1051 | 4" | 4" | 250 (9.84") | 170 (6.69") | 167 (6.57") | 202.5 (7.97") | 254 (10.00") | 317.5 (12.50") | 406 (15.98") |
| FP 1151 | 4" | 4" | 250 (9.84") | 170 (6.69") | 110.5 (4.35") | 146 (5.75") | 197.5 (7.78") | 261 (10.28") | 406 (15.98") |
| FP 1161 | 4" | 4" | 250 (9.84") | 170 (6.69") | 110.5 (4.35") | 146 (5.75") | 197.5 (7.78") | 261 (10.28") | 406 (15.98") |
| FP 1161 | 6" | 4" | 250 (9.84") | 170 (6.69") | 111 (4.37") | 146 (5.75") | 197.5 (7.78") | 261 (10.28") | 406 (15.98") |
| FP 742 | 2.5" | 2" | 195 (7.68") | 96 (3.78") | 101 (3.98") | 143.5 (5.65") | 195 (7.68") | 258.5 (10.18") | 270 (10.63") |
| FP 1732 / 1742 | 2.5" | 2" | 200 (7.87") | 91 (3.58") | 104 (4.09") | 153 (6.02") | 204.5 (8.05") | 268 (10.55") | 270 (10.63") |
| FP 3532 | 2.5" | 2" | 191 (7.52") | 95 (3.74") | 115.5 (4.55") | 164.5 (6.48") | 216 (8.50") | 279.5 (11.00") | 260 (10.24") |
| FP 3542 | 3" | 2.5" | 211 (8.31") | 115 (4.53") | 118 (4.64") | 164.5 (6.48") | 216 (8.50") | 279.5 (11.00") | 290 (11.42") |
| FP 3452 | 3" | 2" | 211 (8.31") | 140 (5.51") | 114 (4.49") | 160.5 (6.32") | 212 (8.35") | 275.5 (10.85") | 350 (13.78") |
| FP 3551 / 3552 | 3" | 2.5" | 231 (9.09") | 140 (5.51") | 119 (4.68") | 170.5 (6.71") | 222 (8.74") | 285.5 (11.24") | 350 (13.78") |

| MOTOR HP | MOTOR | DIMENSIONS IN MILLIMETERS (INCHES) | | | | | | |
|----------|--------|------------------------------------|-----------------|-----------------|----------------|------------------|-------------------|--|
| | | H | J | ØK | L | M | N | |
| 1750 RPM | FRAME | | | | | | | |
| 3500 RPM | | | | | | | | |
| *3 HP | 182TC | 133 (5.23") | 313 (12.31") | 216 (8.50") | 200 (7.87") | 117 (4.62") | 44.5 (1.75") | |
| *5 HP | 213TC | 189 (7.46") | 388 (15.27") | 263 (10.34") | 200 (7.87") | 117 (4.62") | 44.5 (1.75") | |
| **7.5 HP | 213TC | 189 (7.46") | 388 (15.27") | 263 (10.34") | 200 (7.87") | 117 (4.62") | 44.5 (1.75") | |
| **10 HP | 215TC | 189 (7.46") | 416 (16.40") | 263 (10.34") | 200 (7.87") | 117 (4.62") | 44.5 (1.75") | |
| 15 HP | 254TC | 220 (8.67") | 415 (16.33") | 263 (10.34") | 200 (7.87") | 98*** (3.88") | 38**** (1.50") | |
| 20 HP | 256TC | 239 (9.42") | 499 (19.66") | 336 (13.25") | 200 (7.87") | 98*** (3.88") | 38**** (1.50") | |
| 20 HP | 256TC | 225 (8.88") | 491 (19.34") | 263 (10.34") | 200 (7.87") | 98 (3.88") | 38 (1.50") | |
| 25 HP | 284TC | 333 (13.12") | 588 (23.13") | 395 (15.56") | 200 (7.87") | 117 (4.62") | 44.5 (1.75") | |
| 25 HP | 284TSC | 333 (13.12") | 588 (23.13") | 395 (15.56") | 200 (7.87") | 98 (3.88") | 38 (1.50") | |
| 30 HP | 286TC | 333 (13.12") | 588 (23.13") | 395 (15.56") | 200 (7.87") | 117 (4.62") | 44.5 (1.75") | |
| 30 HP | 286TSC | 333 (13.12") | 588 (23.13") | 395 (15.56") | 200 (7.87") | 98 (3.88") | 38 (1.50") | |

* 3551 ONLY
 ** 3551, 1051 & 1151 ONLY
 *** 117 (4.62") FOR 1051, 1151 & 1161
 **** 44.5 (1.75") FOR 1051, 1151 & 1161

1265000387 REV A

FP Double Flange Dimensional Drawing [Frame Sizes 324T(S)C-365T(S)C]

All pump dimensions are in millimeters (inches). Dimensions are based on clamp fittings. Motor dimensions may vary by manufacturer.

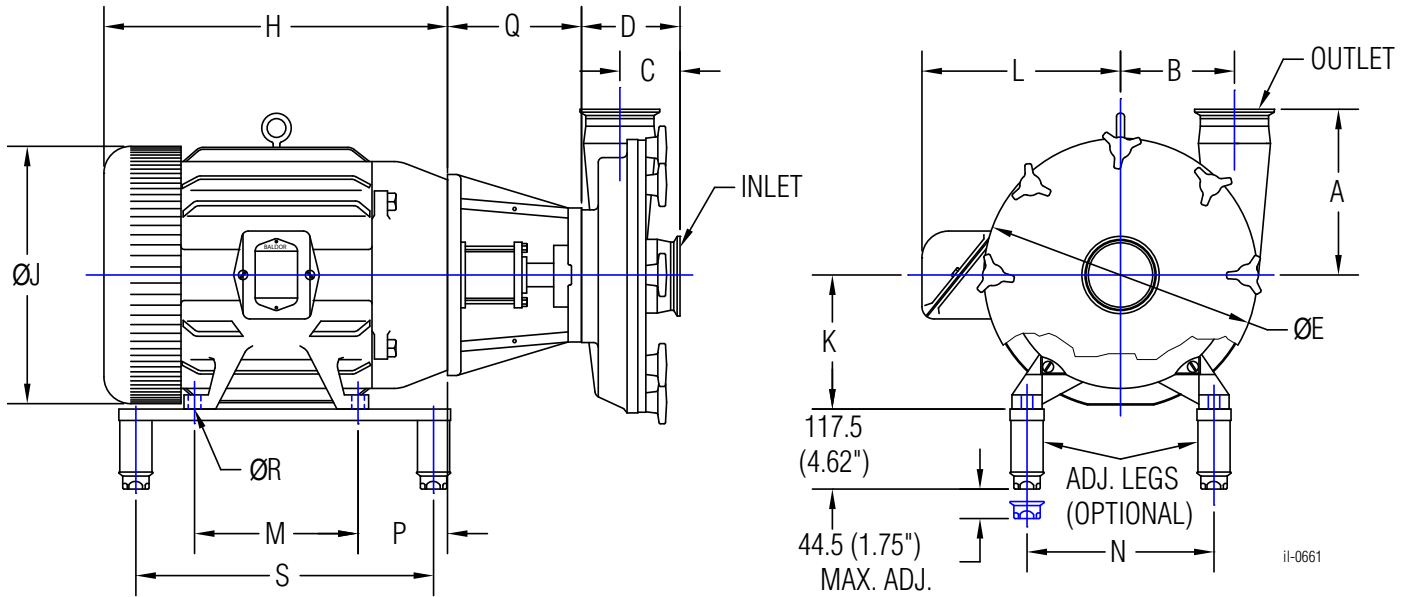

| PUMP MODEL | INLET | OUTLET | DIMENSIONS IN MILLIMETERS (INCHES) | | | | | | MOTOR HP | | MOTOR FRAME | DIMENSIONS IN MILLIMETERS (INCHES) | | | | | | | | | |
|----------------|-------|--------|------------------------------------|----------------|------------------|------------------|-----------------|----------|----------|-------|-------------|------------------------------------|-----------------|----------------|-----------------|-----------------|-----------------|----------------|----------------|------------------|-----------------|
| | | | A | B | C | D | ØE | 1750 RPM | 3500 RPM | H | | ØJ | K | L | M | N | P | Q | ØR | S | |
| FP 1051 | 4" | 4" | 250 (9.84") | 170 (6.69") | 167 (6.57") | 202.5 (7.97") | 406 (15.98") | | 40 HP | | 324TSC | 636 (25.00") | 413 (16.25") | 203 (8.00") | 371 (14.62") | 267 (10.50") | 318 (12.50") | 133 (5.25") | 216 (8.50") | 16.7 (21/32") | 470 (18.50") |
| FP 1151 | 4" | 4" | 250 (9.84") | 170 (6.69") | 110.5 (4.35") | 146 (5.75") | 406 (15.98") | | | 40 HP | 324TSC | 636 (25.00") | 413 (16.25") | 203 (8.00") | 371 (14.62") | 267 (10.50") | 318 (12.50") | 133 (5.25") | 216 (8.50") | 16.7 (21/32") | 470 (18.50") |
| FP 1161 | 4" | 4" | 250 (9.84") | 170 (6.69") | 110.5 (4.35") | 146 (5.75") | 406 (15.98") | | | 50 HP | 326TSC | 636 (25.00") | 413 (16.25") | 203 (8.00") | 371 (14.62") | 305 (12.00") | 318 (12.50") | 133 (5.25") | 216 (8.50") | 16.7 (21/32") | 470 (18.50") |
| FP 1161 | 6" | 4" | 250 (9.84") | 170 (6.69") | 111 (4.37") | 146 (5.75") | 406 (15.98") | | | 50 HP | 326TSC | 636 (25.00") | 413 (16.25") | 203 (8.00") | 371 (14.62") | 305 (12.00") | 318 (12.50") | 133 (5.25") | 216 (8.50") | 16.7 (21/32") | 470 (18.50") |
| FP 1742 | 2.5" | 2" | 200 (7.87") | 91 (3.58") | 104 (4.09") | 153 (6.02") | 270 (10.63") | | 60 HP | | 364TSC | 702 (27.60") | 485 (19.11") | 229 (9.00") | 457 (18.00") | 285 (11.25") | 355 (14.00") | 149 (5.87") | 232 (9.13") | 17.5 (11/16") | 508 (20.00") |
| FP 3542 | 3" | 2.5" | 211 (8.31") | 115 (4.53") | 118 (4.64") | 164.5 (6.48") | 290 (11.42") | | | 60 HP | 364TSC | 702 (27.60") | 485 (19.11") | 229 (9.00") | 457 (18.00") | 285 (11.25") | 355 (14.00") | 149 (5.87") | 232 (9.13") | 17.5 (11/16") | 508 (20.00") |
| FP 3452 | 3" | 2" | 211 (8.31") | 140 (5.51") | 114 (4.49") | 160.5 (6.32") | 350 (13.78") | | | 75 HP | 365TSC | 702 (27.60") | 485 (19.11") | 229 (9.00") | 457 (18.00") | 311 (12.25") | 355 (14.00") | 149 (5.87") | 232 (9.13") | 17.5 (11/16") | 508 (20.00") |
| FP 3551 / 3552 | 3" | 2.5" | 231 (9.09") | 140 (5.51") | 119 (4.68") | 170.5 (6.71") | 350 (13.78") | | | 75 HP | 365TSC | 702 (27.60") | 485 (19.11") | 229 (9.00") | 457 (18.00") | 311 (12.25") | 355 (14.00") | 149 (5.87") | 232 (9.13") | 17.5 (11/16") | 508 (20.00") |

1265000715 REV.

FPX Single Flange Dimensional Drawing

All pump dimensions are in millimeters (inches). Dimensions are based on clamp fittings. Motor dimensions may vary by manufacturer.

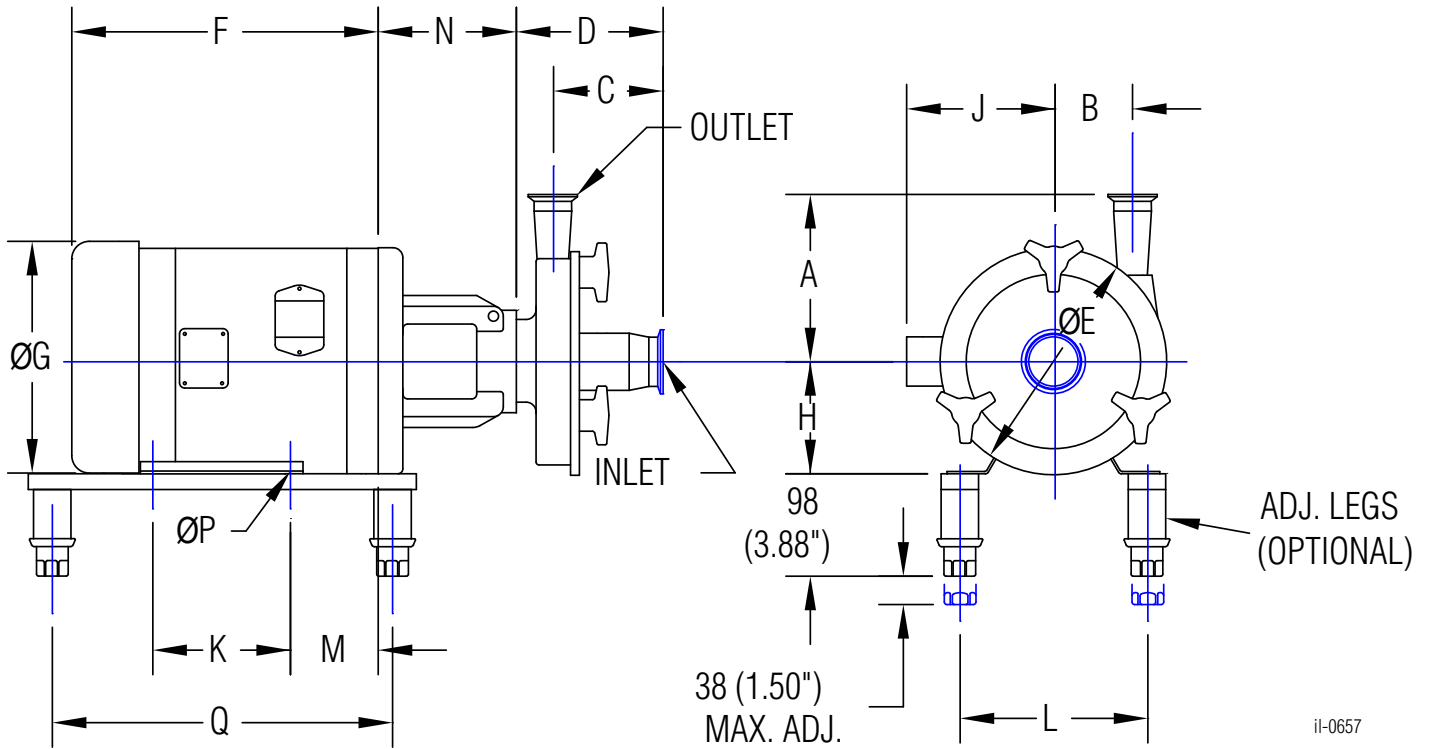

ii-0657

| PUMP MODEL | INLET | OUTLET | DIMENSIONS IN MILLIMETERS (INCHES) | | | | | |
|------------------------|-------|--------|------------------------------------|-----------------|------------------|------------------|-----------------|--|
| | | | A | B | C | D | ØE | |
| FPX 701 / 702 | 1.5" | 1.5" | 108 (4.25") | 44.5 (1.75") | 108.5 (4.27") | 146.5 (5.77") | 150 (5.90") | |
| FPX 711 / 712 | 2" | 1.5" | 144 (5.67") | 58 (2.28") | 113 (4.45") | 150 (5.90") | 185 (7.28") | |
| FPX 721 / 731 / 722 | 2" | 1.5" | 170 (6.69") | 79 (3.11") | 113 (4.45") | 150 (5.90") | 230 (9.06") | |
| FPX 741 / 732 / 742 | 2.5" | 2" | 195 (7.68") | 96 (3.78") | 101 (3.98") | 141 (5.55") | 270 (10.63") | |
| FPX 1741 / 1732 / 1742 | 2.5" | 2" | 200 (7.87") | 91 (3.58") | 104 (4.09") | 150.5 (5.93") | 270 (10.63") | |
| FPX 3521 / 3522 | 2.5" | 2" | 190 (7.48") | 80 (3.15") | 118 (4.64") | 162 (6.38") | 230 (9.06") | |
| FPX 3531 / 3532 | 2.5" | 2" | 191 (7.52") | 95 (3.74") | 115.5 (4.55") | 162 (6.38") | 260 (10.24") | |
| FPX 3541 / 3542 | 3" | 2.5" | 211 (8.31") | 115 (4.53") | 118 (4.64") | 162 (6.38") | 290 (11.42") | |
| FPX 3451 / 3452 | 3" | 2" | 211 (8.31") | 140 (5.51") | 114 (4.49") | 158 (6.22") | 350 (13.78") | |
| FPX 3551 | 3" | 2.5" | 231 (9.09") | 140 (5.51") | 119 (4.68") | 168 (6.61") | 350 (13.78") | |

| MOTOR HP | | MOTOR FRAME | DIMENSIONS IN MILLIMETERS (INCHES) | | | | | | | | | |
|----------|----------|-------------|------------------------------------|-----------------|----------------|----------------|-----------------|-----------------|----------------|----------------|------------------|-----------------|
| 1750 RPM | 3500 RPM | | F | ØG | H | J | K | L | M | N | ØP | Q |
| 1 HP | 1.5 HP | 143TC | 281 (11.06") | 183 (7.19") | 89 (3.50") | 133 (5.22") | 102 (4.00") | 140 (5.50") | 70 (2.75") | 120 (4.72") | 8.7 (11/32") | 356 (14.00") |
| 1.5 HP | | 145TC | 281 (11.06") | 183 (7.19") | 89 (3.50") | 133 (5.22") | 102 (4.00") | 140 (5.50") | 70 (2.75") | 120 (4.72") | 8.7 (11/32") | 356 (14.00") |
| 2 HP | 2 HP | 145TC | 281 (11.06") | 183 (7.19") | 89 (3.50") | 133 (5.22") | 102 (4.00") | 140 (5.50") | 70 (2.75") | 120 (4.72") | 8.7 (11/32") | 356 (14.00") |
| | 3 HP | 182TC | 313 (12.31") | 183 (7.19") | 114 (4.50") | 132 (5.21") | 140 (5.50") | 191 (7.50") | 89 (3.50") | 140 (5.53") | 10.3 (13/32") | 356 (14.00") |
| 3 HP | | 182TC | 348 (13.69") | 183 (7.19") | 114 (4.50") | 132 (5.21") | 140 (5.50") | 191 (7.50") | 89 (3.50") | 140 (5.53") | 10.3 (13/32") | 356 (14.00") |
| | 5 HP | 184TC | 347 (13.68") | 216 (8.50") | 114 (4.50") | 152 (5.97") | 140 (5.50") | 191 (7.50") | 89 (3.50") | 140 (5.53") | 10.3 (13/32") | 356 (14.00") |
| 5 HP | | 184TC | 386 (15.18") | 216 (8.50") | 114 (4.50") | 152 (5.97") | 140 (5.50") | 191 (7.50") | 89 (3.50") | 140 (5.53") | 10.3 (13/32") | 356 (14.00") |
| | 7.5 HP | 184TC | 386 (15.18") | 216 (8.50") | 114 (4.50") | 152 (5.97") | 140 (5.50") | 191 (7.50") | 89 (3.50") | 140 (5.53") | 10.3 (13/32") | 356 (14.00") |
| 7.5 HP | | 213TC | 388 (15.27") | 263 (10.34") | 133 (5.25") | 189 (7.46") | 140 (5.50") | 216 (8.50") | 108 (4.25") | 140 (5.53") | 10.3 (13/32") | 356 (14.00") |
| 10 HP | 10 HP | 215TC | 388 (15.27") | 263 (10.34") | 133 (5.25") | 189 (7.46") | 140 (5.50") | 216 (8.50") | 108 (4.25") | 140 (5.53") | 10.3 (13/32") | 356 (14.00") |
| | 15 HP | 215TC | 436 (17.15") | 263 (10.34") | 133 (5.25") | 189 (7.46") | 140 (5.50") | 216 (8.50") | 108 (4.25") | 140 (5.53") | 10.3 (13/32") | 356 (14.00") |
| 15 HP | | 254TC | 447 (17.59") | 263 (10.34") | 159 (6.25") | 225 (8.88") | 210 (8.25") | 254 (10.00") | 121 (4.75") | 169 (6.65") | 13.5 (17/32") | 406 (16.00") |
| | 20 HP | 256TC | 491 (19.34") | 263 (10.34") | 159 (6.25") | 225 (8.88") | 254 (10.00") | 254 (10.00") | 121 (4.75") | 169 (6.65") | 13.5 (17/32") | 406 (16.00") |
| 20 HP | | 256TC | 499 (19.66") | 336 (13.25") | 159 (6.25") | 239 (9.42") | 254 (10.00") | 254 (10.00") | 121 (4.75") | 169 (6.65") | 13.5 (17/32") | 406 (16.00") |

1265000540

FPX Double Flange Dimensional Drawing

All pump dimensions are in millimeters (inches). Dimensions are based on clamp fittings. Motor dimensions may vary by manufacturer.

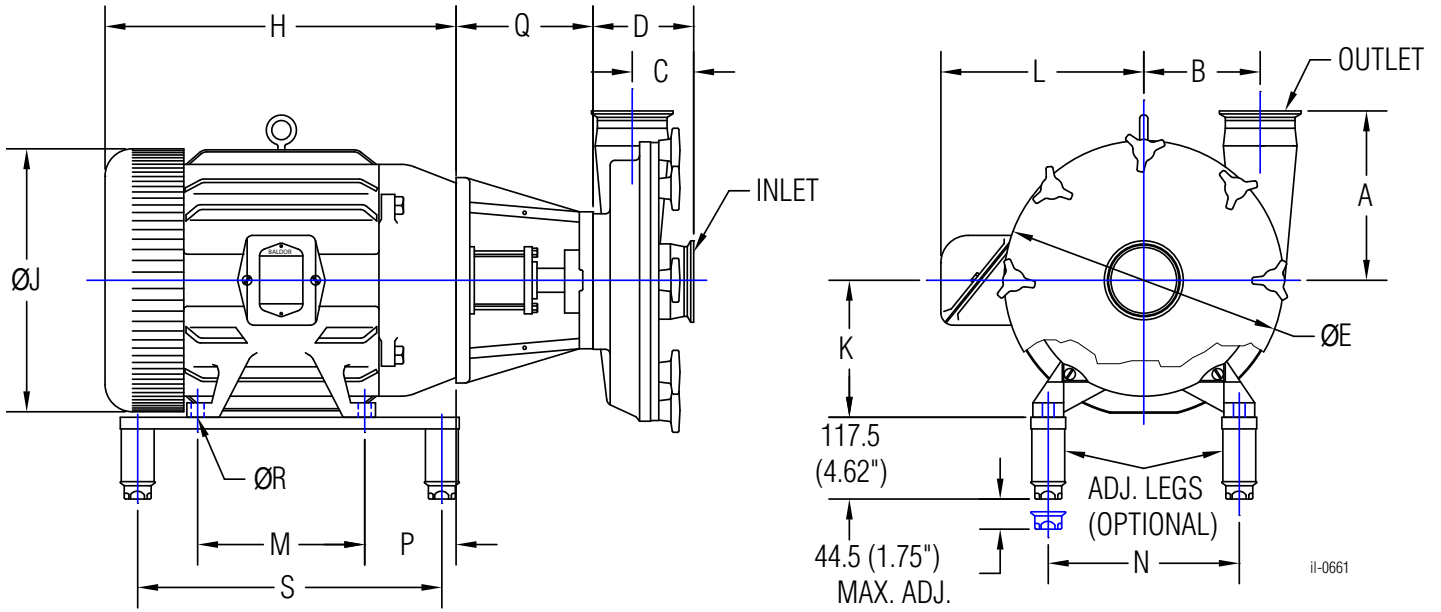

il-0661

| PUMP MODEL | INLET | OUTLET | DIMENSIONS IN MILLIMETERS (INCHES) | | | | |
|------------|-------|--------|------------------------------------|----------------|------------------|------------------|-----------------|
| | | | A | B | C | D | ØE |
| FPX 1051 | 4" | 4" | 250 (9.84") | 170 (6.69") | 167 (6.57") | 202.5 (7.97") | 406 (15.98") |
| FPX 1151 | 4" | 4" | 250 (9.84") | 170 (6.69") | 110.5 (4.35") | 146 (5.75") | 406 (15.98") |
| FPX 1161 | 4" | 4" | 250 (9.84") | 170 (6.69") | 110.5 (4.35") | 146 (5.75") | 406 (15.98") |
| FPX 1161 | 6" | 4" | 250 (9.84") | 170 (6.69") | 111 (4.37") | 146 (5.75") | 406 (15.98") |
| FPX 1742 | 2.5" | 2" | 200 (7.87") | 91 (3.58") | 104 (4.09") | 153 (6.02") | 270 (10.63") |
| FPX 3532 | 2.5" | 2" | 191 (7.52") | 95 (3.74") | 115.5 (4.55") | 164.5 (6.48") | 260 (10.24") |
| FPX 3542 | 3" | 2.5" | 211 (8.31") | 115 (4.53") | 118 (4.64") | 164.5 (6.48") | 290 (11.42") |
| FPX 3452 | 3" | 2" | 211 (8.31") | 140 (5.51") | 114 (4.49") | 160.5 (6.32") | 350 (13.78") |
| FPX 3552 | 3" | 2.5" | 231 (9.09") | 140 (5.51") | 119 (4.68") | 170.5 (6.71") | 350 (13.78") |

| MOTOR HP | MOTOR FRAME | DIMENSIONS IN MILLIMETERS (INCHES) | | | | | | | | | | |
|----------|-------------|------------------------------------|-----------------|----------------|-----------------|-----------------|-----------------|----------------|----------------|------------------|-----------------|----|
| | | 1750 RPM | 3500 RPM | H | ØJ | K | L | M | N | P | Q | ØR |
| 7.5 HP | 213TC | 388 (15.27") | 263 (10.34") | 133 (5.25") | 189 (7.46") | 140 (5.50") | 216 (8.50") | 108 (4.25") | 200 (7.87") | 10.3 (13/32") | 470 (18.50") | |
| | | 416 (16.40") | 263 (10.34") | 133 (5.25") | 189 (7.46") | 178 (7.00") | 216 (8.50") | 108 (4.25") | 200 (7.87") | 10.3 (13/32") | 470 (18.50") | |
| 10 HP | 215TC | 447 (17.59") | 270 (10.62") | 159 (6.25") | 226 (8.88") | 210 (8.25") | 254 (10.00") | 121 (4.75") | 200 (7.87") | 13.5 (17/32") | 444 (17.50") | |
| | | 499 (19.66") | 320 (12.60") | 159 (6.25") | 239 (9.42") | 254 (10.00") | 254 (10.00") | 121 (4.75") | 200 (7.87") | 13.5 (17/32") | 470 (18.50") | |
| 20 HP | 256TC | 588 (23.13") | 367 (14.44") | 178 (7.00") | 333 (13.11") | 241 (9.50") | 279 (11.00") | 121 (4.75") | 200 (7.87") | 13.5 (17/32") | 444 (17.50") | |
| | | 588 (23.13") | 367 (14.44") | 178 (7.00") | 333 (13.11") | 241 (9.50") | 279 (11.00") | 121 (4.75") | 200 (7.87") | 13.5 (17/32") | 444 (17.50") | |
| 25 HP | 284TC | 588 (23.13") | 367 (14.44") | 178 (7.00") | 333 (13.11") | 241 (9.50") | 279 (11.00") | 121 (4.75") | 200 (7.87") | 13.5 (17/32") | 444 (17.50") | |
| | | 588 (23.13") | 367 (14.44") | 178 (7.00") | 333 (13.11") | 241 (9.50") | 279 (11.00") | 121 (4.75") | 200 (7.87") | 13.5 (17/32") | 444 (17.50") | |
| 30 HP | 286TC | 588 (23.13") | 367 (14.44") | 178 (7.00") | 333 (13.11") | 241 (9.50") | 279 (11.00") | 121 (4.75") | 200 (7.87") | 13.5 (17/32") | 444 (17.50") | |
| | | 588 (23.13") | 367 (14.44") | 178 (7.00") | 333 (13.11") | 241 (9.50") | 279 (11.00") | 121 (4.75") | 200 (7.87") | 13.5 (17/32") | 444 (17.50") | |
| 40 HP | 324TC | 636 (25.00") | 413 (16.25") | 203 (8.00") | 371 (14.62") | 267 (10.50") | 318 (12.50") | 133 (5.25") | 216 (8.50") | 16.7 (21/32") | 470 (18.50") | |
| | | 636 (25.00") | 413 (16.25") | 203 (8.00") | 371 (14.62") | 267 (10.50") | 318 (12.50") | 133 (5.25") | 216 (8.50") | 16.7 (21/32") | 470 (18.50") | |
| 50 HP | 326TC | 636 (25.00") | 413 (16.25") | 203 (8.00") | 371 (14.62") | 305 (12.00") | 318 (12.50") | 133 (5.25") | 216 (8.50") | 16.7 (21/32") | 470 (18.50") | |
| | | 636 (25.00") | 413 (16.25") | 203 (8.00") | 371 (14.62") | 305 (12.00") | 318 (12.50") | 133 (5.25") | 216 (8.50") | 16.7 (21/32") | 470 (18.50") | |

il-0660

FPR Single Flange Dimensional Drawing

All pump dimensions are in millimeters (inches). Dimensions are based on clamp fittings. Motor dimensions may vary by manufacturer.

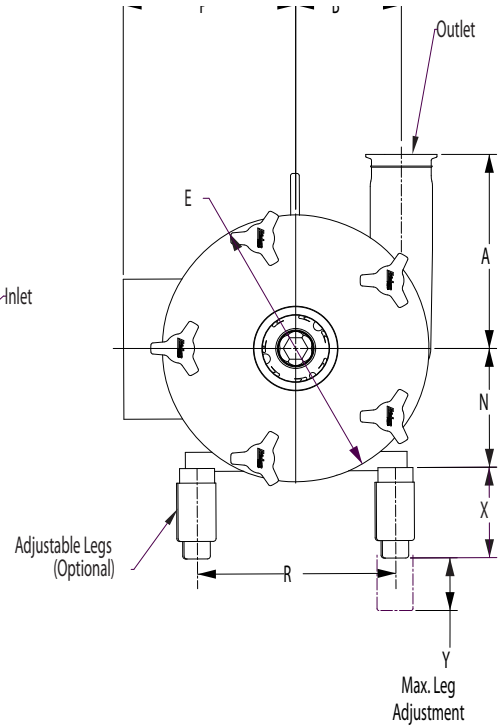
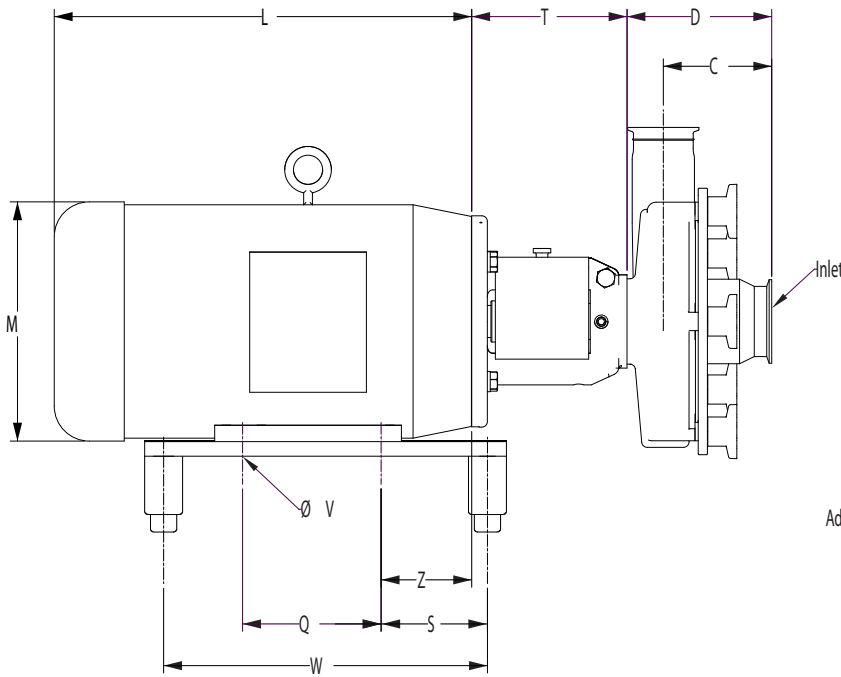

| MOTOR HP | | MOTOR FRAME | L | M | N | P | Q | R | S | T | V | W | X | Y | Z |
|----------|----------|-------------|---------------|---------------|--------------|---------------|--------------|--------------|--------------|--------------|---------------|--------------|--------------|-------------|----------------|
| 1750 RPM | 3500 RPM | | | | | | | | | | | | | | |
| 1 HP | 1.5 HP | 143TC | 284 11.18" | 175 6.89" | 89 3.5" | 133 5.25" | 101.6 4" | 140 5.5" | 127 5" | 120 4.72" | 8.7 0.34" | 356 14" | 98 3.86" | 38 1.5" | 57.2 2.25" |
| 1.5 HP | | 145TC | 284 11.18" | 175 6.89" | 89 3.5" | 133 5.25" | 127 5" | 140 5.5" | 127 5" | 120 4.72" | 8.7 0.34" | 356 14" | 98 3.86" | 38 1.5" | 57.2 2.25" |
| 2 HP | 2 HP | 145TC | 284 11.18" | 175 6.89" | 89 3.5" | 133 5.25" | 127 5" | 140 5.5" | 127 5" | 120 4.72" | 8.7 0.34" | 356 14" | 98 3.86" | 38 1.5" | 57.2 2.25" |
| | 3 HP | 182TC | 340 13.39" | 221 8.7" | 114 4.5" | 149 5.87" | 114 4.5" | 191 7.5" | 108 4.25" | 169 6.65" | 10.3 0.41" | 356 14" | 98 3.86" | 38 1.5" | 69.9 2.75" |
| 3 HP | | 182TC | 354 13.94" | 221 8.7" | 114 4.5" | 149 5.87" | 114 4.5" | 191 7.5" | 108 4.25" | 169 6.65" | 10.3 0.41" | 356 14" | 98 3.86" | 38 1.5" | 69.9 2.75" |
| | 5 HP | 184TC | 354 13.94" | 221 8.7" | 114 4.5" | 149 5.87" | 114 4.5" | 191 7.5" | 108 4.25" | 169 6.65" | 10.3 0.41" | 356 14" | 98 3.86" | 38 1.5" | 69.9 2.75" |
| 5 HP | | 184TC | 354 13.94" | 221 8.7" | 114 4.5" | 149 5.87" | 114 4.5" | 191 7.5" | 108 4.25" | 169 6.65" | 10.3 0.41" | 356 14" | 98 3.86" | 38 1.5" | 69.9 2.75" |
| | 7.5 HP | 184TC | 423 16.65" | 221 8.7" | 114 4.5" | 149 5.87" | 140 5.5" | 191 7.5" | 108 4.25" | 169 6.65" | 10.3 0.41" | 356 14" | 98 3.86" | 38 1.5" | 69.9 2.75" |
| 7.5 HP | | 213TC | 403 15.87" | 260 10.25" | 133 5.25" | 187 7.38" | 140 5.5" | 216 8.5" | 108 4.25" | 169 6.65" | 10.3 0.41" | 356 14" | 98 3.86" | 38 1.5" | 88.9 3.5" |
| | 10 HP | 215TC | 403 15.87" | 260 10.25" | 133 5.25" | 187 7.38" | 178 7" | 216 8.5" | 108 4.25" | 169 6.65" | 10.3 0.41" | 356 14" | 98 3.86" | 38 1.5" | 88.9 3.5" |
| 10 HP | | 215TC | 416 16.38" | 260 10.25" | 133 5.25" | 187 7.38" | 178 7" | 216 8.5" | 108 4.25" | 169 6.65" | 10.3 0.41" | 356 14" | 98 3.86" | 38 1.5" | 88.9 3.5" |
| | 15 HP | 215TC | 515 20.28" | 260 10.25" | 133 5.25" | 187 7.38" | 178 7" | 216 8.5" | 108 4.25" | 169 6.65" | 10.3 0.41" | 356 14" | 98 3.86" | 38 1.5" | 88.9 3.5" |
| 15 HP | | 254TC | 499 19.65" | 327 12.87" | 159 6.25" | 244 9.63" | 210 8.25" | 254 10" | 102 4" | 169 6.65" | 13.5 0.53" | 406 16" | 98 3.86" | 38 1.5" | 108.0 4.25" |
| | 20 HP | 256TC | 499 19.65" | 327 12.87" | 159 6.25" | 244 9.63" | 254 10" | 254 10" | 102 4" | 169 6.65" | 13.5 0.53" | 406 16" | 98 3.86" | 38 1.5" | 108.0 4.25" |
| 20 HP | | 256TC | 499 19.65" | 327 12.87" | 159 6.25" | 244 9.63" | 254 10" | 254 10" | 102 4" | 169 6.65" | 13.5 0.53" | 406 16" | 98 3.86" | 38 1.5" | 108.0 4.25" |
| | 25 HP | 284TSC | 588 23.15" | 371 14.63" | 178 7" | 333 13.13" | 241 9.5" | 279 11" | 121 4.75" | 179 7.05" | 13.5 0.53" | 445 17.5" | 118 4.63" | 45 1.75" | 120.7 4.75" |
| 25 HP | | 284TC | 588 23.15" | 371 14.63" | 178 7" | 333 13.13" | 241 9.5" | 279 11" | 121 4.75" | 179 7.05" | 13.5 0.53" | 445 17.5" | 118 4.63" | 45 1.75" | 120.7 4.75" |
| | 30 HP | 286TSC | 588 23.15" | 371 14.63" | 178 7" | 333 13.13" | 279 11" | 279 11" | 121 4.75" | 179 7.05" | 13.5 0.53" | 445 17.5" | 118 4.63" | 45 1.75" | 120.7 4.75" |
| 30 HP | | 286TC | 588 23.15" | 371 14.63" | 178 7" | 333 13.13" | 279 11" | 279 11" | 121 4.75" | 179 7.05" | 13.5 0.53" | 445 17.5" | 118 4.63" | 45 1.75" | 120.7 4.75" |
| | 40 HP | 324TSC | 636 25.04" | 419 16.5" | 203 8" | 359 14.13" | 267 10.5" | 318 12.5" | 121 4.75" | 179 7.05" | 16.7 0.66" | 470 18.5" | 118 4.63" | 45 1.75" | 133.4 5.25" |
| 40 HP | | 324TC | 636 25.04" | 419 16.5" | 203 8" | 359 14.13" | 267 10.5" | 318 12.5" | 121 4.75" | 179 7.05" | 16.7 0.66" | 470 18.5" | 118 4.63" | 45 1.75" | 133.4 5.25" |
| | 50 HP | 326TSC | 636 25.04" | 419 16.5" | 203 8" | 359 14.13" | 305 12" | 318 12.5" | 121 4.75" | 179 7.05" | 16.7 0.66" | 470 18.5" | 118 4.63" | 45 1.75" | 133.4 5.25" |
| 50 HP | | 326TC | 636 25.04" | 419 16.5" | 203 8" | 359 14.13" | 305 12" | 318 12.5" | 121 4.75" | 179 7.05" | 16.7 0.66" | 470 18.5" | 118 4.63" | 45 1.75" | 133.4 5.25" |

1265000702 Dev A

| PUMP MODEL | INLET | OUTLET | A | B | C | D | E |
|-----------------|-------|--------|--------------|---------------|----------------|----------------|---------------|
| FPR 701/702 | 1.5" | 1.5" | 108 4.25" | 44.5 1.75" | 106.5 4.19" | 139.5 5.49" | 150 5.91" |
| FPR 711/712 | 2" | 1.5" | 144 5.67" | 58 2.28" | 113 4.45" | 145 5.71" | 185 7.28" |
| FPR 721/731/722 | 2" | 1.5" | 170 6.69" | 79 3.11" | 113 4.45" | 145 5.71" | 230 9.06" |
| FPR 741/742 | 2.5" | 2" | 195 7.68" | 96 3.78" | 101 3.98" | 136 5.35" | 270 10.63" |
| FPR 1741/1742 | 2.5" | 2" | 200 7.87" | 91 3.58" | 104 4.09" | 145.5 5.73" | 270 10.63" |
| FPR 3521/3522 | 2.5" | 2" | 190 7.48" | 80 3.15" | 118 4.65" | 157.5 6.2" | 230 9.06" |
| FPR 3531/3532 | 2.5" | 2" | 191 7.52" | 95 3.74" | 115.5 4.55" | 157.5 6.2" | 260 10.24" |
| FPR 3541/3542 | 3" | 2.5" | 211 8.31" | 115 4.53" | 118 4.65" | 157.5 6.2" | 290 11.42" |

1265000463

FPR Double Flange Dimensional Drawing

All pump dimensions are in millimeters (inches). Dimensions are based on clamp fittings. Motor dimensions may vary by manufacturer.

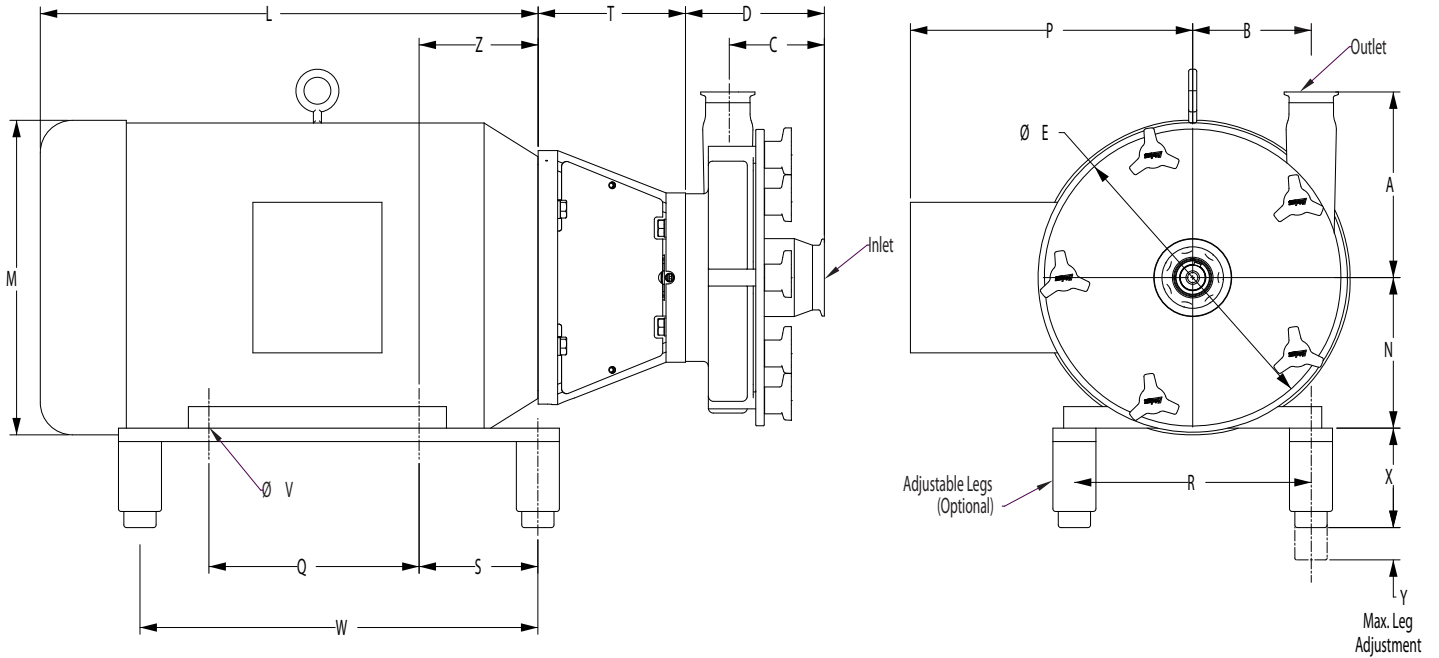

1265000203 Rev C

| MOTOR HP | | MOTOR FRAME | L | M | N | P | Q | R | S | T | V | W | X | Y | Z |
|----------|----------|-------------|---------------|---------------|--------------|---------------|---------------|--------------|--------------|--------------|---------------|--------------|--------------|-------------|---------------|
| 1750 RPM | 3500 RPM | | | | | | | | | | | | | | |
| | 3 HP | 182TC | 313 12.32" | 221 8.7" | 114 4.5" | 149 5.87" | 114 4.5" | 191 7.5" | 108 4.25" | 160 6.3" | 10.3 0.41" | 356 14" | 98 3.86" | 38 1.5" | 69.9 2.75" |
| 3 HP | | 182TC | 348 13.7" | 221 8.7" | 114 4.5" | 149 5.87" | 114 4.5" | 191 7.5" | 108 4.25" | 160 6.3" | 10.3 0.41" | 356 14" | 98 3.86" | 38 1.5" | 69.9 2.75" |
| | 5 HP | 184TC | 347 13.66" | 221 8.7" | 114 4.5" | 149 5.87" | 140 5.5" | 191 7.5" | 108 4.25" | 160 6.3" | 10.3 0.41" | 356 14" | 98 3.86" | 38 1.5" | 69.9 2.75" |
| 5 HP | | 184TC | 386 15.2" | 221 8.7" | 114 4.5" | 149 5.87" | 140 5.5" | 191 7.5" | 108 4.25" | 160 6.3" | 10.3 0.41" | 356 14" | 98 3.86" | 38 1.5" | 69.9 2.75" |
| | 7.5 HP | 184TC | 386 15.2" | 221 8.7" | 114 4.5" | 149 5.87" | 140 5.5" | 191 7.5" | 108 4.25" | 160 6.3" | 10.3 0.41" | 356 14" | 98 3.86" | 38 1.5" | 69.9 2.75" |
| 7.5 HP | | 213TC | 388 15.28" | 260 10.25" | 133 5.25" | 187 7.38" | 140 5.5" | 216 8.5" | 108 4.25" | 160 6.3" | 10.3 0.41" | 356 14" | 98 3.86" | 38 1.5" | 88.9 3.5" |
| | 10 HP | 215TC | 388 15.28" | 260 10.25" | 133 5.25" | 187 7.38" | 7" | 216 8.5" | 108 4.25" | 160 6.3" | 10.3 0.41" | 356 14" | 98 3.86" | 38 1.5" | 88.9 3.5" |
| | 15 HP | 215TC | 436 17.17" | 260 10.25" | 133 5.25" | 187 7.38" | 7" | 216 8.5" | 108 4.25" | 160 6.3" | 10.3 0.41" | 356 14" | 98 3.86" | 38 1.5" | 88.9 3.5" |
| | 15 HP | 254TC | 447 17.6" | 327 12.87" | 159 6.25" | 244 9.63" | 210 8.25" | 254 10" | 102 4" | 160 6.3" | 13.5 0.53" | 406 16" | 98 3.86" | 38 1.5" | 108 4.25" |
| | 20 HP | 256TC | 491 19.33" | 327 12.87" | 159 6.25" | 244 9.63" | 210 8.25" | 254 10" | 102 4" | 160 6.3" | 13.5 0.53" | 406 16" | 98 3.86" | 38 1.5" | 108 4.25" |
| | 20 HP | 256TC | 499 19.65" | 327 12.87" | 159 6.25" | 244 9.63" | 210 8.25" | 254 10" | 102 4" | 160 6.3" | 13.5 0.53" | 406 16" | 98 3.86" | 38 1.5" | 108 4.25" |
| | 25 HP | 284TC | 588 23.15" | 371 14.63" | 178 7" | 333 13.13" | 241 9.5" | 279 11" | 121 4.75" | 174 6.85" | 13.5 0.53" | 445 17.5" | 118 4.63" | 45 1.75" | 121 4.75" |
| | 25 HP | 284TSC | 588 23.15" | 371 14.63" | 178 7" | 333 13.13" | 241 9.5" | 279 11" | 121 4.75" | 174 6.85" | 13.5 0.53" | 445 17.5" | 118 4.63" | 45 1.75" | 121 4.75" |
| | 30 HP | 286TC | 588 23.15" | 371 14.63" | 178 7" | 333 13.13" | 279 11" | 279 11" | 121 4.75" | 174 6.85" | 13.5 0.53" | 445 17.5" | 118 4.63" | 45 1.75" | 121 4.75" |
| | 30 HP | 286TSC | 588 23.15" | 371 14.63" | 178 7" | 333 13.13" | 279 11" | 279 11" | 121 4.75" | 174 6.85" | 13.5 0.53" | 445 17.5" | 118 4.63" | 45 1.75" | 121 4.75" |
| | 40 HP | 324TC | 636 25.04" | 419 16.5" | 203 8" | 359 14.13" | 267 10.5" | 318 12.5" | 121 4.75" | 209 8.23" | 16.7 0.66" | 470 18.5" | 118 4.63" | 45 1.75" | 133 5.25" |
| | 40 HP | 324TSC | 636 25.04" | 419 16.5" | 203 8" | 359 14.13" | 267 10.5" | 318 12.5" | 121 4.75" | 209 8.23" | 16.7 0.66" | 470 18.5" | 118 4.63" | 45 1.75" | 133 5.25" |
| | 50 HP | 326TC | 636 25.04" | 419 16.5" | 203 8" | 359 14.13" | 305 12" | 318 12.5" | 121 4.75" | 209 8.23" | 16.7 0.66" | 470 18.5" | 118 4.63" | 45 1.75" | 133 5.25" |
| | 50 HP | 326TSC | 636 25.04" | 419 16.5" | 203 8" | 359 14.13" | 305 12" | 318 12.5" | 121 4.75" | 209 8.23" | 16.7 0.66" | 470 18.5" | 118 4.63" | 45 1.75" | 133 5.25" |
| | 60 HP | 364TC | 685 26.97" | 470 18.5" | 229 9" | 383 15.06" | 286 11.25" | 356 14" | 89 3.5" | 209 8.23" | 16.7 0.66" | 508 20" | 127 5" | 45 1.75" | 149 5.87" |
| | 60 HP | 364TSC | 685 26.97" | 470 18.5" | 229 9" | 383 15.06" | 286 11.25" | 356 14" | 89 3.5" | 209 8.23" | 16.7 0.66" | 508 20" | 127 5" | 45 1.75" | 149 5.87" |
| | 75 HP | 365TC | 685 26.97" | 470 18.5" | 229 9" | 383 15.06" | 311 12.25" | 356 14" | 89 3.5" | 209 8.23" | 16.7 0.66" | 508 20" | 127 5" | 45 1.75" | 149 5.87" |
| | 75 HP | 365TSC | 685 26.97" | 470 18.5" | 229 9" | 383 15.06" | 311 12.25" | 356 14" | 89 3.5" | 209 8.23" | 16.7 0.66" | 508 20" | 127 5" | 45 1.75" | 149 5.87" |

| PUMP MODEL | INLET | OUTLET | A | B | C | D | E |
|---------------|-------|--------|--------------|--------------|----------------|----------------|---------------|
| FPR 751/752 | 3" | 2" | 205 8.07" | 145 5.71" | 99 3.9" | 142 5.59" | 379 14.92" |
| FPR 3451/3452 | 3" | 2" | 211 8.31" | 140 5.51" | 114 4.49" | 160.5 6.32" | 350 13.78" |
| FPR 3551/3552 | 3" | 2.5" | 230 9.06" | 140 5.51" | 119 4.69" | 170 6.69" | 350 13.78" |
| FPR 3642 | 4" | 4" | 226 8.9" | 154 6.06" | 142 5.59" | 197 7.76" | 276 10.87" |
| FPR 1051 | 4" | 4" | 250 9.84" | 170 6.69" | 167 6.57" | 202.5 7.97" | 406 15.98" |
| FPR 1161 | 4" | 4" | 250 9.84" | 170 6.69" | 110.5 4.35" | 146 5.75" | 406 15.98" |
| FPR 3001 | 4" | 4" | 232 9.13" | 191 7.52" | 97 3.82" | 138 5.43" | 350 13.78" |

FPR Double Flange Dimensional Drawing [Model 4001]

All pump dimensions are in millimeters (inches). Dimensions are based on clamp fittings. Motor dimensions may vary by manufacturer.

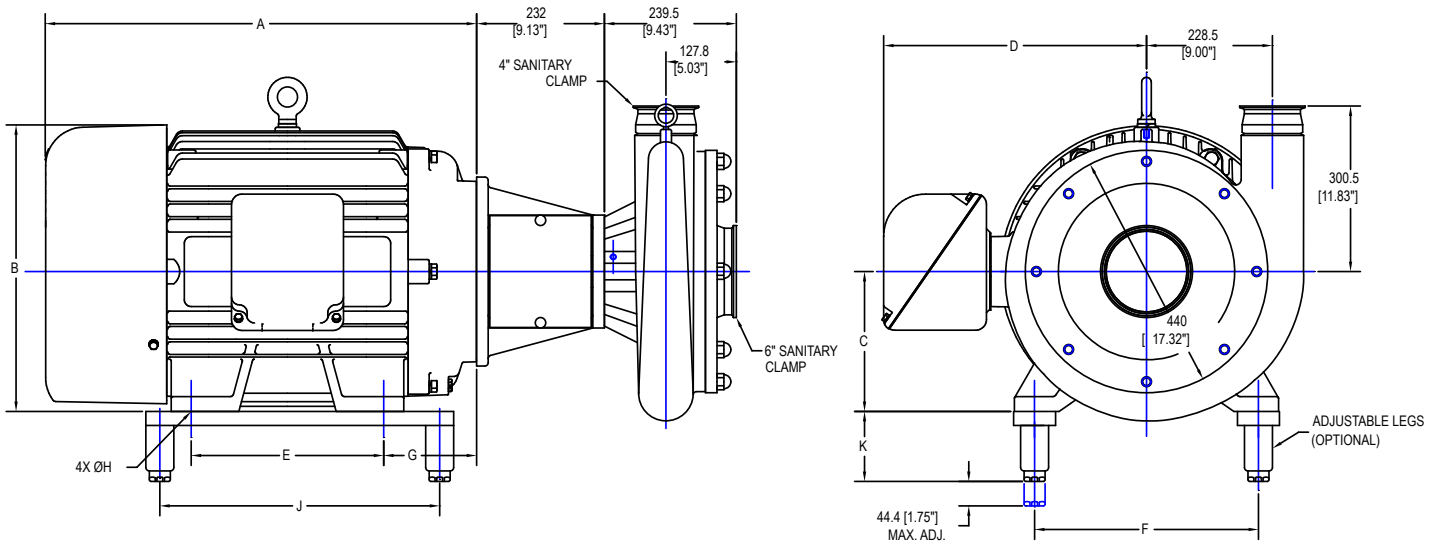

126500053
8/19/02

| MOTOR HP | MOTOR FRAME | A | B | C | D | E | F | G | ØH | J | K |
|----------|-------------|--------------|--------------|------------|--------------|--------------|--------------|-------------|--------------|--------------|-------------|
| 40 HP | 324TC | 636 25" | 418 16.5" | 203 8" | 371 14.6" | 267 10.5" | 317 12.5" | 133 5.2" | 16.7 0.7" | 470 18.5" | 117 4.6" |
| 50 HP | 326TC | 636 25" | 418 16.5" | 203 8" | 371 14.6" | 305 12" | 317 12.5" | 133 5.2" | 16.7 0.7" | 470 18.5" | 117 4.6" |
| 60 HP | 364TC | 684 26.9" | 470 18.5" | 229 9" | 380 15" | 286 11.3" | 355 14" | 149 5.9" | 16.7 0.7" | 508 20" | 127 5" |
| 75 HP | 365TC | 684 26.9" | 470 18.5" | 229 9" | 380 15" | 311 12.2" | 355 14" | 149 5.9" | 16.7 0.7" | 508 20" | 127 5" |
| 100 HP | 405TC | 782 30.8" | 520 20.5" | 254 10" | 477 18.8" | 349 13.7" | 406 16" | 168 6.6" | 20.6 0.8" | 508 20" | 127 5" |

126500054
1/28/2008



CENTRIFUGAL



POSITIVE DISPLACEMENT



MIXING & BLENDING