



Engineered For Lasting Performance®

INSTRUCTION AND MAINTENANCE MANUAL:

FS Shear Blender (FPX-style seal, before 8/2005)

(for pumps with motors frame sizes 140TC thru 320TC)



SANITARY MIXING AND BLENDING EQUIPMENT

DESCRIPTION

This manual contains installation, operation, assembly, disassembly and repair instructions for the Fristam FS style pump.

The FS style pump is flange mounted on a heavy duty cast flange support. This flange support provides an extremely sturdy method of coupling the pump head and the motor. It absorbs vibrations and noise. The flange support also fastens the pump to the floor (or adjustable base).

The motors used on FS style pumps are standard NEMA totally enclosed fan cooled (TEFC) motors. They are C-face and have a locked front bearing. These motors do not require feet. Replacement motors are readily available from local motor distributors.

Motor size determines the type of shaft collar used.



CAUTION: Begin all pump maintenance operations by disconnecting the energy source to the pump. Observe all lock out/tag out procedures as outlined by ANSI Z244.1-1982 and OSHA 1910.147 to prevent accidental start-up and injury.

TABLE OF CONTENTS

TECHNICAL INFORMATION.....	4
RECOMMENDED PREVENTIVE MAINTENANCE.....	5
SEAL REPLACEMENT	6-13
PUMP HEAD DISASSEMBLY.....	6-7
ADDITIONAL DISASSEMBLY FOR DOUBLE MECHANICAL SEALS ONLY	7
PUMP HEAD ASSEMBLY	7-9
SHEAR SINGLE SEAL ASSEMBLY DRAWING.....	10
SHEAR SINGLE SILICON CARBIDE STATIONARY SEAL ASSEMBLY.....	11
SHEAR DOUBLE SEAL ASSEMBLY DRAWING.....	12
SHEAR DOUBLE SILICON CARBIDE STATIONARY SEAL ASSEMBLY.....	13
PUMP SHAFT AND/OR MOTOR REPLACEMENT.....	14-15
PUMP DISASSEMBLY.....	14
PUMP ASSEMBLY	15
SETTING THE ROTOR GAP	15
FS SERIES EXPLODED VIEW.....	16-17
INSTALLATION	18-19
ELECTRICAL INSTALLATION.....	19
PUMP OPERATIONS	19
INSTALLATION OF WATER FLUSH FOR DOUBLE MECHANICAL SEAL.....	20
TROUBLESHOOTING	21-23
NOTICE OF TERMS, WARRANTY PROVISIONS INCLUDING DISCLAIMERS, CLAIMS AND LIMITATION OF LIABILITY.....	27

TECHNICAL INFORMATION

SPECIFICATIONS

Maximum Inlet Pressure 150 PSI
 Temperature Range -40°F - 400°F

MATERIALS OF CONSTRUCTION

Primary Product Contact Components AISI 316L
 Cover Gasket BUNA (standard)
 Also available in Viton, EPDM, Silicone, Chemraz, Kalrez
 Surface Finish for Product Contact Surfaces 32 Ra (standard)
 Also available in 25 Ra, 20 Ra, 15 Ra and electropolish

SHAFT SEALS

Mechanical Seal Type Single or Double Internal
 Seal Flush Water Pressure (double seal only) 5 Max. PSI
 Seal Water Consumption (double seal only) 1-2 gph
 Stationary Seal Ring Material Carbon (standard)
 Also available in Silicon Carbide
 Rotating Seal Ring Material Chrome Oxide coated Stainless Steel
 Also available in Silicon Carbide
 O-ring Material Viton (standard)
 Also available in contact Customer Service

RECOMMENDED TORQUE VALUES

Rotor nut	40 ft. lb.	
Housing clamping bolt	55 ft. lb.	
Motor bolts	20 ft.-lb.	(for 50C - 140TC motor frames)
Motor bolts	55 ft.-lb.	(up to 320TSC motor frames)
Seal retaining ring bolts	4.5 ft. lb.	
Shaft collar screw	6 ft.-lb.	(for 140TC - 180TC motor frames)
Shaft collar screw	15 ft.-lb.	(for 210TC - 280TC motor frames)
Shaft collar screw	40 ft.-lb.	(for 280TC - 360TC motor frames)
Acorn nuts on front cover	65 in.-lb.	

MOTOR INFORMATION

Uses standard NEMA TEFC C-face motors. Options include washdown, high efficiency, explosion proof, chemical duty and IEC. The TIR of the motor shaft should be 0.002” or less.

VOLTAGE AND FREQUENCY

3 phase, 60 Hz, 208-230/460 VAC 1750/3500 RPM
 3 phase, 60 Hz, 575 VAC 1750/3500 RPM
 3 phase, 50 Hz, 208-220/380-415 VAC 1450/2900 RPM

ROTOR TO STATOR GAPS

352, 353, 354, 355 0.5 mm (0.020”)

RECOMMENDED PREVENTIVE MAINTENANCE

RECOMMENDED SEAL MAINTENANCE

Visually inspect mechanical seal daily for leakage.
 Replace mechanical seal annually under normal duty.
 Replace mechanical seal as often as required under heavy duty.

ELASTOMER INSPECTION

Inspect all elastomers when performing pump maintenance. We recommend replacing elastomers (o-rings and gaskets) during seal, pump shaft and/or motor replacement. If the impeller nut gasket fails, the threaded hole on the impeller nut and the threads on the end of the shaft will need to be cleaned. A wire brush is recommended for cleaning these threads.

PUMP SHAFT INSPECTION

Inspect annually.

MOTOR LUBRICATION RECOMMENDATIONS

Use a high grade ball and roller bearing grease. Recommendations for standard service conditions include *Shell Dolium R* or *Chevron SRI*. (See *Tables 1-3* for more details.)

Table 1: Motor Lubrication Intervals for Standard Conditions

NEMA/(IEC) Frame Size	Rate Speed - RPM	
	3500	1750
Up to 210 incl. (132 IEC)	5,500 hrs.	12,000 hrs.
Up to 320TSC incl. (180 IEC)	3,600 hrs.	9,500 hrs.

For severe service conditions, multiply interval hours by .5
 For extreme service conditions, multiply interval hours by .1

Table 2: Service Condition Definitions

Service Conditions	Maximum Ambient Temperature	Atmospheric Contamination
Standard	104°F (40°C)	Clean, little corrosion
Severe	122°F (50°C)	Moderate dirt, corrosion
Extreme	>122°F (>50°C)	Severe, dirt abrasive dust, corrosion

Table 3: Volume of Grease to be Added per Bearing

NEMA/(IEC) Frame Size	Grease IN. ³	Volume TSP
Up to 210 incl. (132 IEC)	0.6	2.0
Up to 320TSC incl. (180 IEC)	1.2	3.9

SEAL REPLACEMENT



Begin all pump maintenance by disconnecting the energy source to the pump. Observe all lock out/tag out procedures as outlined by ANSI Z244.1-1982 and OSHA 1910.147 to prevent accidental start-up and injury.

TOOLS FOR SEAL REPLACEMENT

- 15/16" socket
- Two 3/4" wrenches
- 7/16" wrench
- 9/16" wrench
- 3/32" Allen wrench
- 3/8" diameter steel rod
- Pliers (channel locks)
- Screwdriver (flat blade)
- Soft-faced hammer (5 lb. dead-blow)
- Food grade lubricant
- Optional: One pair of impeller pullers

PUMP HEAD DISASSEMBLY

Note: the reference numbers listed in the text (#) refer to the assembly drawing on pages 16-17.



WARNING

Disconnect the suction and discharge piping from the pump. Drain all fluid from the pump prior to disassembly.

- a) Loosen the cover nuts (24) with the soft-faced hammer and remove.
- b) Remove the pump cover (23) and the cover gasket (19).
- c) Loosen the acorn nuts (41) on the front of the cover and remove.
- d) Remove the stator (39) and two o-rings (44 & 45). Discard the o-rings.
- e) Remove the seal water pipes (on pumps with a double mechanical seal only) by turning them counter-clockwise with the pliers.
- f) Loosen and remove the guard screw (34). Next remove the shaft guard (35).
- g) Place the 3/8" diameter rod in the pump shaft hole. Allow the rod to rest against the pump flange support (2) to prevent the shaft from rotating while loosening the rotor nut (22) with the 15/16" socket wrench (*Figure 7*). Remove the rotor nut and the rotor nut gasket (21).
- h) Remove the rotor (38) from the pump shaft (6) by grasping a rotor blade in each hand and pulling the rotor toward you.
- i) Compress the seal spring (18) by pushing on the front seal driver (32) and lift out the rotor key (8) (*Figure 8*). (You may find it easier to rotate the keyway to bottom of the shaft, compress the seal spring, and let the key drop out.)
- j) Next remove the front seal driver (32) and seal spring (18) by pulling them off the pump shaft and discard them.
- k) Remove the rotating seal (29), seal washer (27) and o-ring (11) by gently placing the flat ends of two rotor pullers on either side of the rotating seal and carefully pull (wiggling the seal ring side-to-side should aid removal) until the rotating seal face comes off

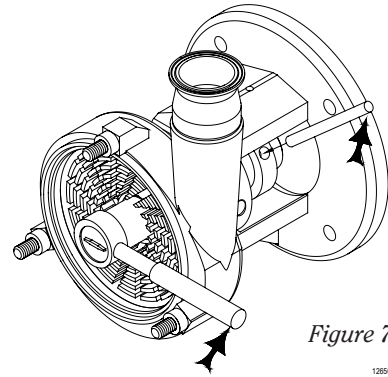

Figure 7

136500122
9/2003

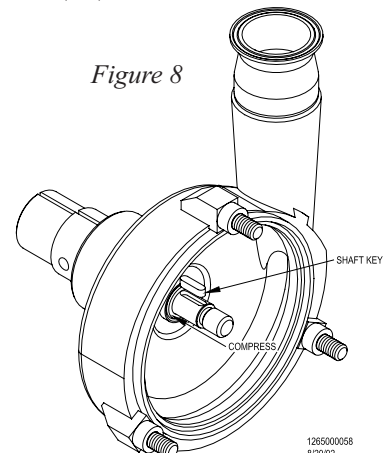
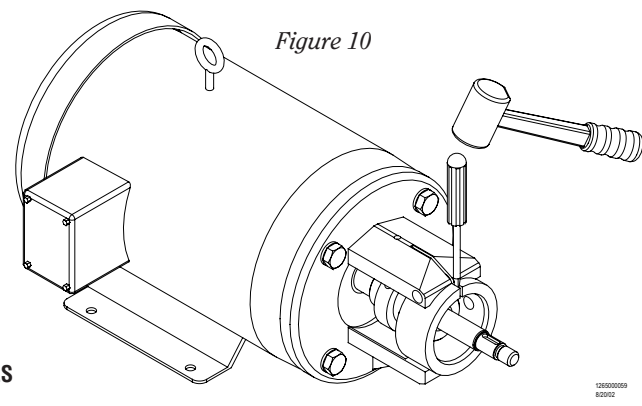
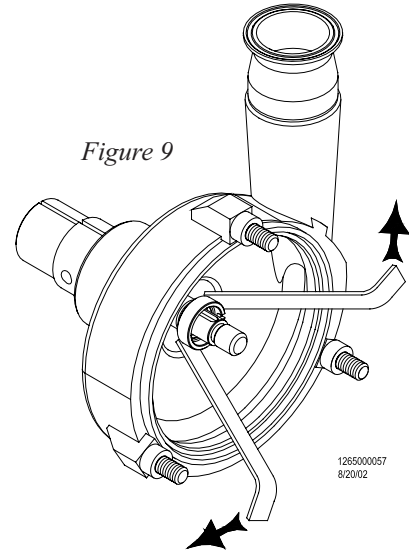

Figure 8

126500058
8/2002

the shaft (*Figure 9*). Discard the seal components after you remove them.

- l) Loosen the housing clamping bolt (4) with the two 3/4" wrenches until it is loose in the flange support (2). (Note: the clamping bolt does not have to be removed.) Now slide the housing off the end of the pump shaft (6). If the housing does not come out of the flange support easily, widen the flange support by driving a screwdriver into the slot on top (*Figure 10*).
 - m) Place the housing (17) face down on the housing studs (30).
 - n) Loosen the retaining ring bolts (12) with the 7/16" or 9/16" wrench (depending on seal size) and remove them from the hub of the stator.
 - o) Remove the retaining ring (13).
 - p) Place a finger through the stationary seal (15), pull it out of the seal cavity and discard. If the stationary seal has been in the pump for an extended period, it may be necessary to softly tap it out from the opposite end using a rubber mallet.
- If you have a Silicon Carbide Stationary Seal design - two pieces will be removed (15a and 15b)*
- q) Check for the flat gasket (16) in the bottom of the seal cavity. Remove this gasket, discard and clean the seal cavity if necessary.



ADDITIONAL DISASSEMBLY FOR DOUBLE MECHANICAL SEALS ONLY

To remove the rear seal components (only pumps with double seal), carefully slide the rear rotating seal (28), seal washer (27), the seal o-ring (11) off the pump shaft and discard. Use the 3/32" Allen wrench to remove the rear seal driver and spring (10) off the pump shaft and discard.

PUMP HEAD ASSEMBLY - (SEE SEAL ASSEMBLY DRAWINGS - FIGURE 17 - 20 - PAGES 10-13)

NOTE: when installing the new seal components make sure that you use all of the components supplied with the replacement seal kit. Using some of the old components may reduce seal life.

For double mechanical seals only, first install the rear seal components. Note: this includes the seal washer (27), the seal o-ring (11), the rear rotating seal (28) and the rear seal driver and spring (10).

You are now ready to install the stationary seal into the pump.

- a) To install the stationary seal (15) into the hub of the housing (17), place the housing on a clean surface with the hub side up. Inspect the hub area to ensure that it is clean.

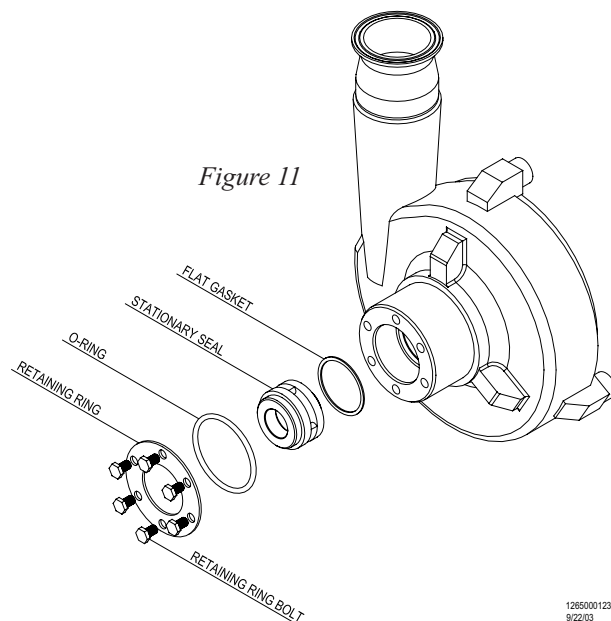

b) Place the flat gasket (16) into the hub of the housing. Make sure that it is all the way to the bottom and is seated evenly.

c) Install the stationary seal into the housing hub with the smaller face entering the hub first.

For the Silicon Carbide Stationary Seal design (Figures 18 and 20) - install the front half of the stationary seal (15a) into the housing hub with the smaller face side first. Then install the rear half of the stationary seal (15b).

d) Install the stationary seal o-ring (14) (do not lubricate this o-ring) onto the back of the stationary seal (15). Improper fit may cause leakage or seal damage.

e) Place the retaining ring (13) on the housing hub, aligning the holes in the retaining ring with the holes in the hub. Thread the retaining ring bolts (12) through the holes in the stationary seal retaining ring and into the housing hub. Alternately tighten the bolts so the retaining ring secures evenly. Uneven tightening could result in seal damage. Check for proper torque on page 5.

f) Carefully slide the pump housing over the pump shaft (6) and back against the flange support (2). *The stationary seal may be damaged if it makes hard contact with the pump shaft.* If the housing does not slide into the flange support easily, widen the flange support by driving a screwdriver into the slot on top (Figure 12). Slide the housing all the way into the flange support until the shoulder of the housing is against the flange support. Remove the screwdriver. If the pump has a double mechanical seal, make sure that the water pipe holes in the housing are aligned with the holes in the flange support.

g) While holding the housing against the flange support, tighten the clamping bolt (4) in the flange support.

h) Install the seal water pipes (for double mechanical seals only), by threading them into the housing and tighten with the pliers.

i) You are now ready to install the rotating seal assembly. First lubricate the seal o-ring (11) with a food grade lubricant (unless the o-ring material is EPDM, then only water should be used for lubrication). Place the seal o-ring inside the rotating seal (29).

j) Now place the seal washer (27) into the rotating seal.

k) Next install the one end of the seal spring (18) into the rotating seal making sure that the tab of the spring is in the slot on the rotating seal.

l) Finally, install the tab on the other end of the seal spring into the hole on the front seal driver (32) (Figure 13). The rotating seal assembly is now ready to be installed onto the pump shaft.

m) Rotate the pump shaft (6) so the keyway is on top. Now slide the rotating seal assembly which includes: the rotating seal (29), the seal o-ring (11), the seal washer (27), the seal spring (18) and the seal driver (32) onto the pump shaft.

n) Lubricate the outside o-ring (33) with a food grade lubricant, if it is not EPDM, and install it in the groove on the front of the seal spring and driver assembly.

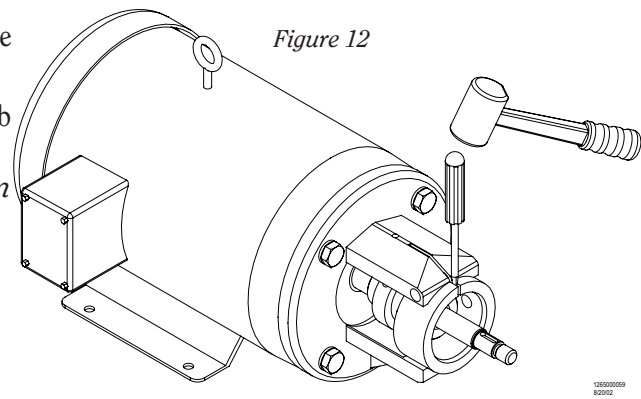
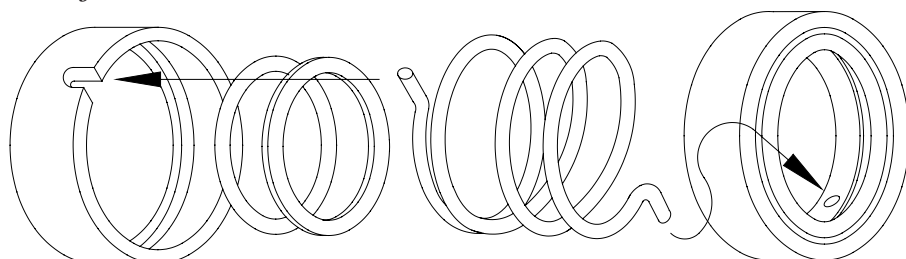
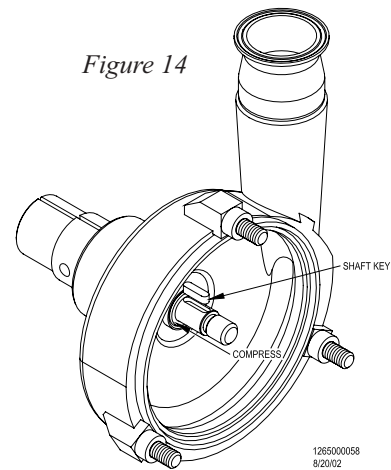

Figure 13



- o) Compress the spring assembly with two fingers and install the shaft key (8) into the keyway on the pump shaft (*Figure 14*).
- p) Slide the rotor (38) onto the pump shaft (6). The slot in the rotor hub will slide over the rotor key (8).
- q) Generously lubricate the new rotor nut gasket (21) with a food grade lubricant (if it is not EPDM) and place it onto the rotor nut (22).
- r) Thread the rotor nut with the gasket in place onto the pump shaft (6).
- s) Place the 5/16" diameter rod in the pump shaft hole. Allow the rod to rest against the pump flange support to keep the shaft from rotating while tightening the rotor nut with the 15/16" socket wrench (*Figure 15*). Tighten to the proper torque listed on page 5.



- t) Generously lubricate the two stator o-rings (44 & 45) and place onto the stator (39).
- u) Reinstall the stator (39) onto the pump cover (23). Tighten the acorn nuts (41) onto the studs (40) to the proper torque listed on page 5.
- v) Now install the new cover gasket (19) onto the pump cover (23). When placing the cover gasket into the pump cover, gently stretch the gasket into position. Do not roll the gasket into position. With the cover gasket in position, place the pump cover onto the front of the pump. (*Note: the pump serial number is embossed into the 'top' of the pump cover.*)

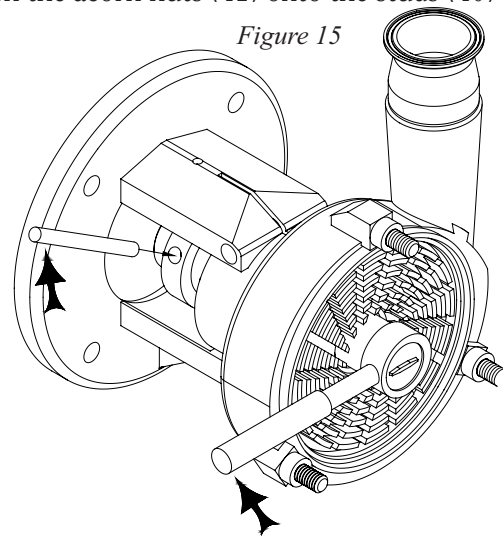

- w) Thread the cover nuts (24) onto the housing studs (30). Make sure the cover o-ring is properly seated in the cover to ensure that it will not get pinched when tightening the cover nuts. Tighten the cover nuts by tapping on them with the soft-faced hammer.
- x) Now rotate the pump shaft (6) to make sure that the rotor (38) moves freely. If it does not, recheck your assembly to make sure that gaskets are not pinched and everything is seated properly. Listen to the pump as you turn the shaft. A small amount of noise from the seals is normal, but if there is metal-to-metal contact, the sound will be noticeable. If there is metal-to-metal contact, check the rotor gap. Regap the rotor if necessary. See page 20 for directions. Replace the shaft guard and secure with the guard screws.

Reconnect the suction and discharge piping.

WARNING: Mechanical seals must never run dry, even momentarily. Seal damage will result.

Figure 16: Single Seal Assembly

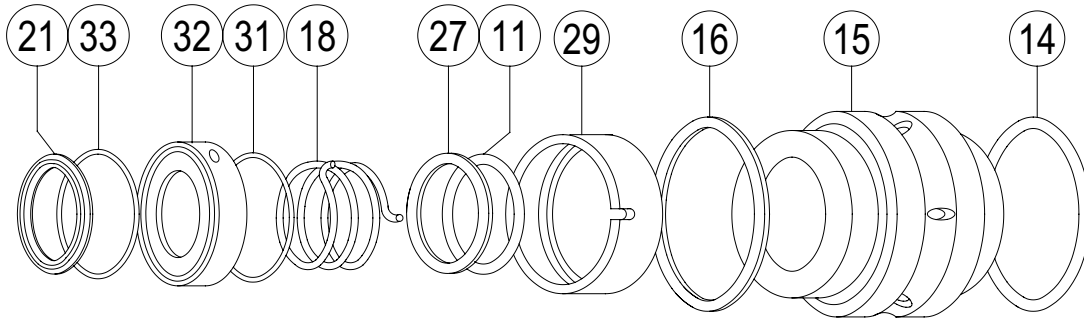

DESCRIPTION

- | | |
|-------------------------------|---------------------------|
| 21 ROTOR NUT GASKET | 11 ROTATING SEAL O-RING |
| 33 OUTSIDE SEAL DRIVER O-RING | 29 ROTATING SEAL |
| 32 FRONT SEAL DRIVER | 16 FLAT GASKET |
| 31 INSIDE SEAL DRIVER O-RING | 15 STATIONARY SEAL |
| 18 SEAL SPRING | 14 STATIONARY SEAL O-RING |
| 27 ROTATING SEAL WASHER | |

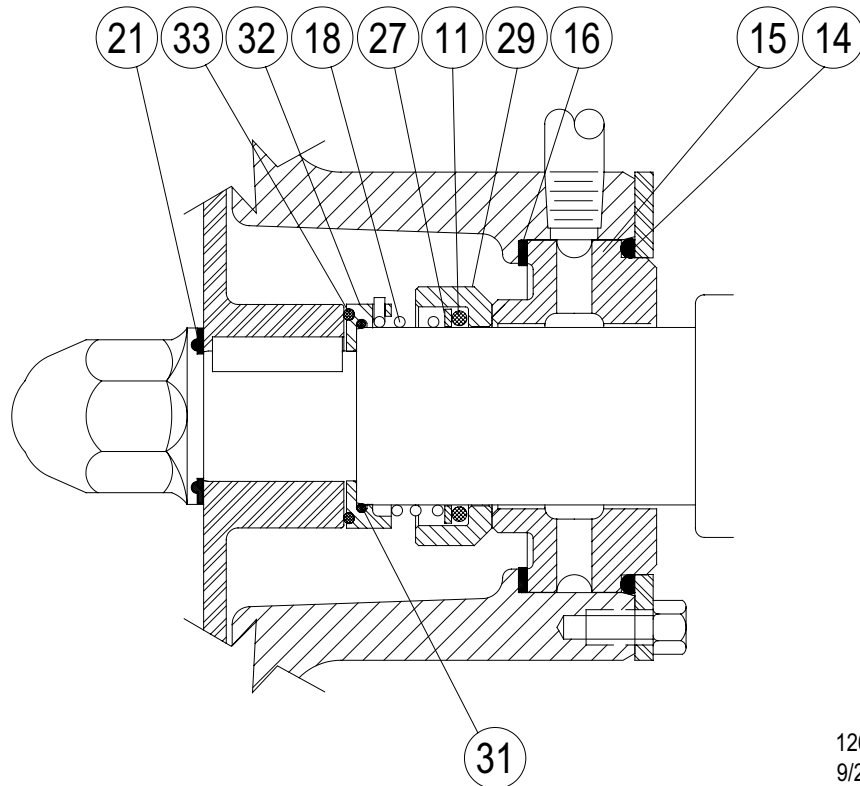

1265000125
9/22/03

Figure 17: Single Silicon Carbide Stationary Seal Assembly

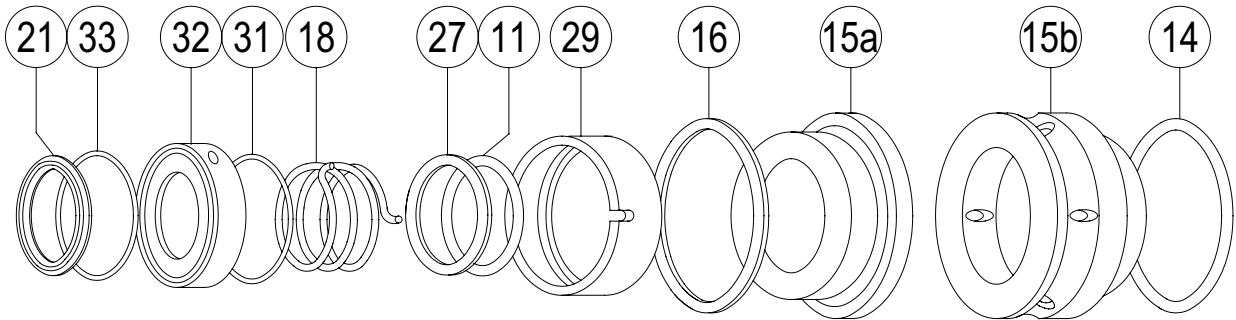

DESCRIPTION

- | | |
|---------------------------------|------------------------------------|
| (21) ROTOR NUT GASKET | (11) ROTATING SEAL O-RING |
| (33) OUTSIDE SEAL DRIVER O-RING | (29) ROTATING SEAL |
| (32) FRONT SEAL DRIVER | (16) FLAT GASKET |
| (31) INSIDE SEAL DRIVER O-RING | (15a) STATIONARY SEAL - FRONT HALF |
| (18) SEAL SPRING | (15b) STATIONARY SEAL - REAR HALF |
| (27) ROTATING SEAL WASHER | (14) STATIONARY SEAL O-RING |

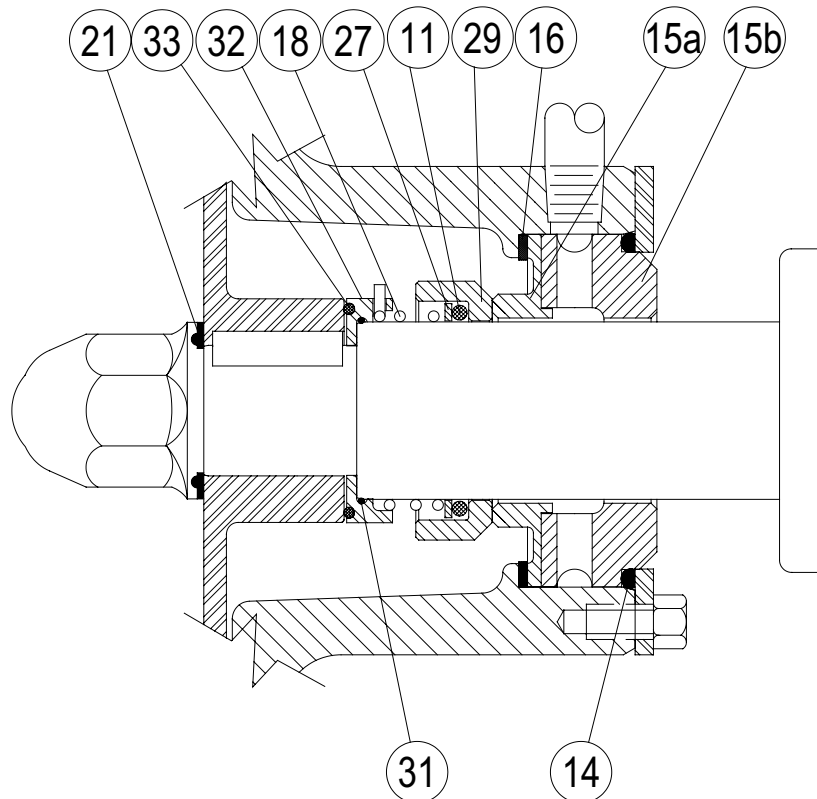

1265000126
9/22/03

Figure 18: Double Seal Assembly

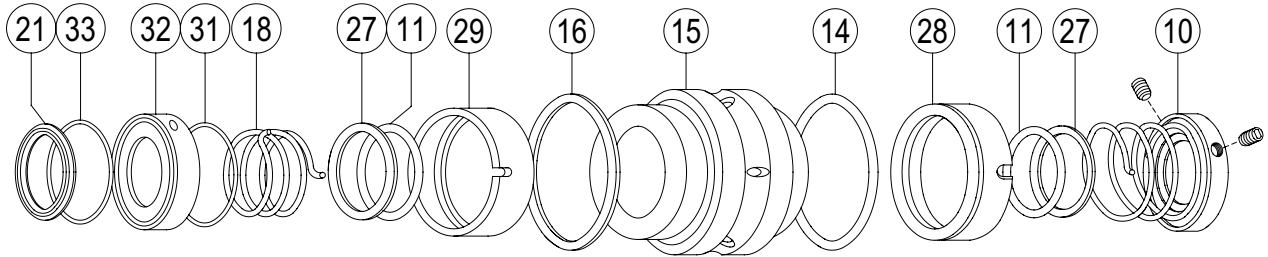

DESCRIPTION

- | | |
|-------------------------------|---|
| 21 ROTOR NUT GASKET | 29 FRONT ROTATING SEAL |
| 33 OUTSIDE SEAL DRIVER O-RING | 16 FLAT GASKET |
| 32 FRONT SEAL DRIVER | 15 STATIONARY SEAL |
| 31 INSIDE SEAL DRIVER O-RING | 14 STATIONARY SEAL O-RING |
| 18 FRONT SEAL SPRING | 28 REAR ROTATING SEAL |
| 27 ROTATING SEAL WASHER | 10 REAR SEAL DRIVER & SPRING & SET SCREWS |
| 11 ROTATING SEAL O-RING | |

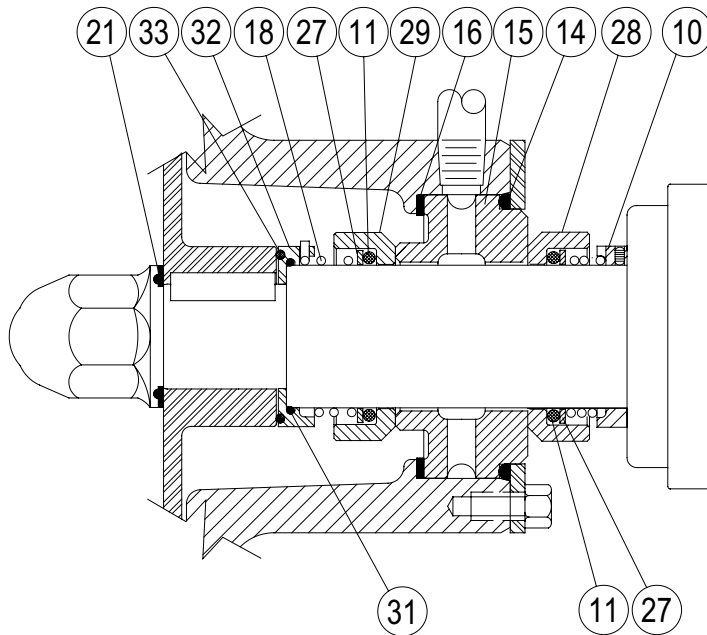

1265000127
9/22/03

Figure 19: Double Silicon Carbide Stationary Seal Assembly

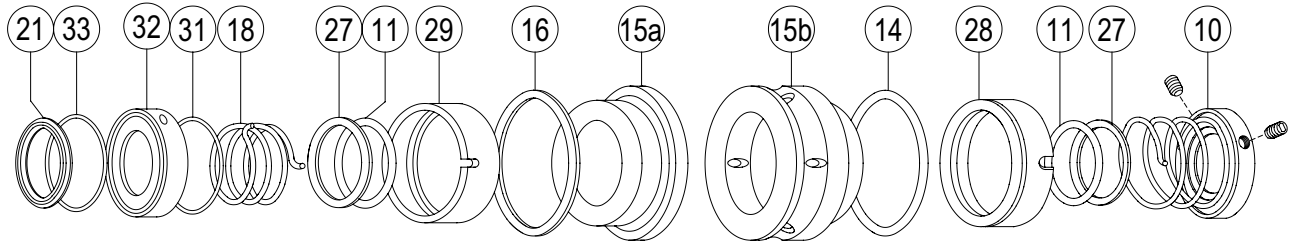

DESCRIPTION

- | | |
|-------------------------------|---|
| 21 ROTOR NUT GASKET | 29 FRONT ROTATING SEAL |
| 33 OUTSIDE SEAL DRIVER O-RING | 16 FLAT GASKET |
| 32 FRONT SEAL DRIVER | 15a STATIONARY SEAL - FRONT HALF |
| 31 INSIDE SEAL DRIVER O-RING | 15b STATIONARY SEAL - REAR HALF |
| 18 FRONT SEAL SPRING | 14 STATIONARY SEAL O-RING |
| 27 ROTATING SEAL WASHER | 28 REAR ROTATING SEAL |
| 11 ROTATING SEAL O-RING | 10 REAR SEAL DRIVER & SPRING & SET SCREWS |

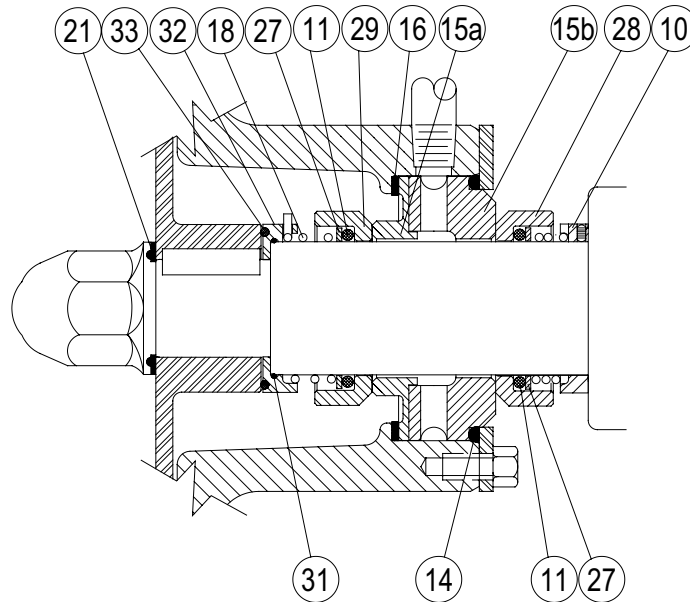

1265000128
9/22/03

PUMP SHAFT AND/OR MOTOR REPLACEMENT



Begin all pump maintenance by disconnecting the energy source to the pump. Observe all lock out/tag out procedures as outlined by ANSI Z244.1-1982 and OSHA 1910.147 to prevent accidental start-up and injury.

TOOLS FOR PUMP SHAFT AND/OR MOTOR REPLACEMENT:

- | | |
|--------------------|-----------------------------------|
| One 9/16" wrench | (for 143TC - 145TC motor frames) |
| One 3/4" wrench | (for 182TC - 320TSC motor frames) |
| Soft-faced hammer | |
| Gapping shim | |
| Dial indicator | |
| 3/16" Allen wrench | |
| 1/4" Allen wrench | |

PUMP DISASSEMBLY

Disassemble the pump as described on pages 6-7.

- Loosen the shaft collar screw (36) on the shaft collar (37) with the 3/16" or 1/4" Allen wrench (depending on the motor frame size).
- Pull the pump shaft off the motor shaft. If necessary, rotate the pump shaft and tap with the soft-faced mallet to loosen the pump shaft from the motor shaft.

If the pump shaft does not pull off the motor shaft, the housing (17) and rotor (38) can be reinstalled to aid in removal (*Figure 21*). To do this, first ensure that the stationary seal (15) is not in the housing. Next install the housing onto the flange support (2). **DO NOT TIGHTEN THE FLANGE CLAMPING BOLT (4)**. Install the rotor onto the pump shaft and place a clean cloth or brass shim between the rotor and housing to prevent the rotor from scratching the housing during the shaft removal process. Thread the rotor nut (22) and rotor nut gasket (21) onto the shaft and tighten by hand. Now pull on the stator to loosen the pump shaft from the motor shaft. Tapping on the back of the stator with the soft-faced mallet may be required.

ADDITIONAL INSTRUCTIONS FOR MOTOR REPLACEMENT -

Loosen the four motor bolts (26) and remove the motor bolts and lock washers (25). (Use the 9/16" wrench for 140TC motor frames and 3/4" wrench for 180TC - 320TSC motor frames.) Remove the flange support (2) from the motor.

Figure 20

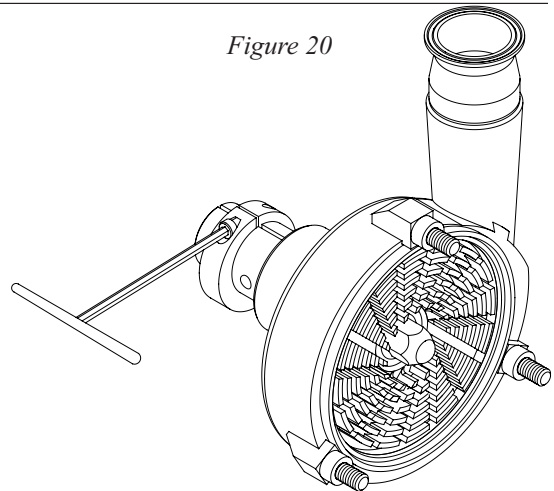

1265000129
9/22/03

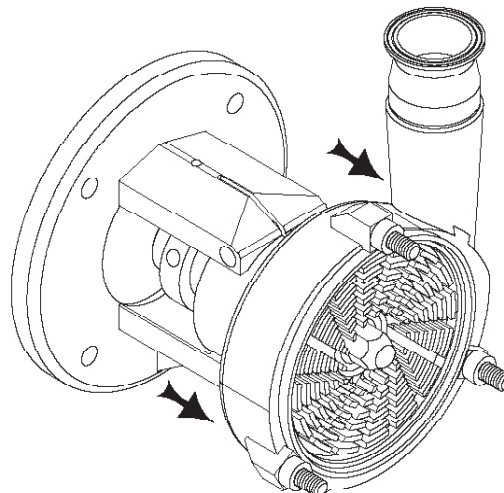

Figure 21

1265000130
9/22/03

PUMP ASSEMBLY

If you have replaced the motor, clean off the motor face of the flange support (2). Place the flange support onto the new motor and replace the motor bolts (26) and lock washers (25). Tighten the motor bolts to the torque indicated on page 5.

ASSEMBLING THE PUMP SHAFT ONTO THE MOTOR SHAFT

Note: when replacing the shaft, replace the shaft collar at the same time.

- a) Slide the new shaft collar (37) onto the pump shaft, do not tighten the shaft collar screw at this time.
- b) Slide the pump shaft and shaft collar onto the motor shaft with the hole in the pump shaft aligned with the key in the motor shaft.

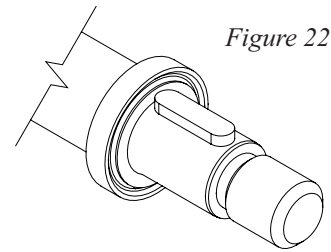

Figure 22

1265000079
12/19/02

SETTING THE ROTOR GAP

If you have removed the pump shaft (6) from the motor shaft for any reason (such as replacing the shaft or motor), you must re-set the gap.

The gap is measured between the rotor (38) and housing (17).

- a) Assemble the housing (17) (without the stationary seal) onto the flange support (2). Make sure that the shoulder of the housing bottoms out against the flange support.
- b) Tighten the clamping bolt (4) in the flange support. Note: make sure the housing is level or in line with the piping.
- c) Place the front seal driver (32) onto the pump shaft (6).
- d) Place the rotor key (8) and rotor (38) onto the shaft (6). Thread the rotor nut (22) onto the shaft and tighten.
- e) Set the gap by placing a 0.5 mm feeler gauge behind the stator (39) (Figure 24). Note: the stator o-rings shouldn't be in place at this time.
- f) *Align the slot of the shaft collar (37) directly over one of the slots on the shaft (Figure 23).*
- g) Push shaft forward so rotor is tight to stator and shim.

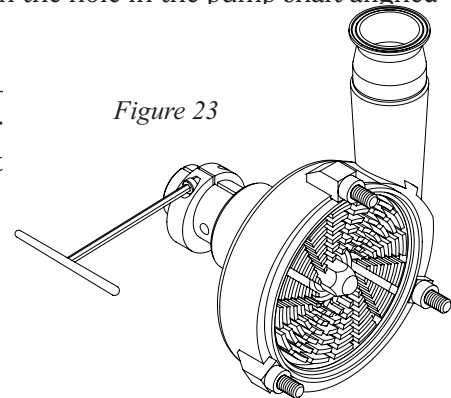

Figure 23

1265000129
8/22/03

- h) Tighten the shaft collar screw (36) in the shaft collar (37) to the proper torque, see page 5 (Figure 23).
- i) Remove the shim.

Now remove the rotor nut (22), rotor (38), rotor key (8), front seal driver (32) and stator (39).

Now you are ready to assemble the pump head as described on pages 7-9.

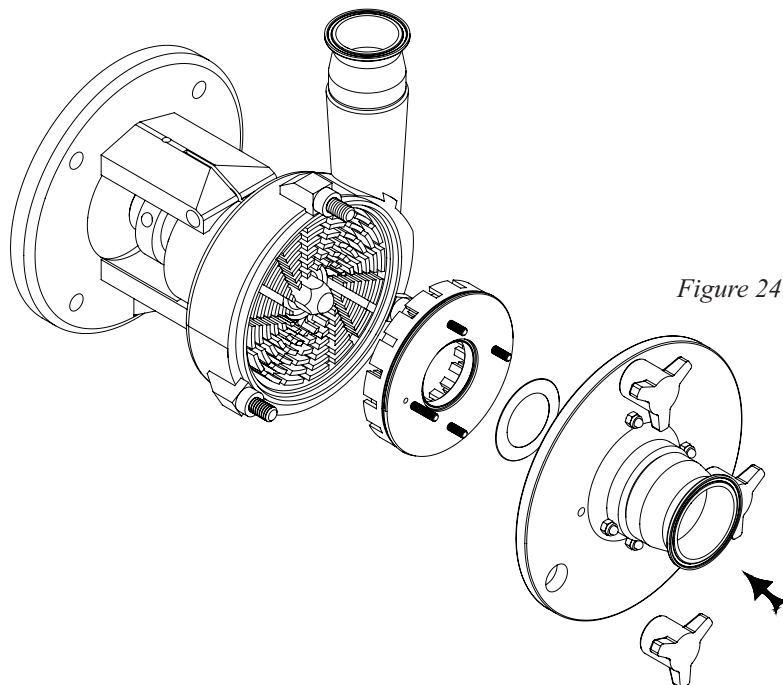

Figure 24

1265000131
10/8/03

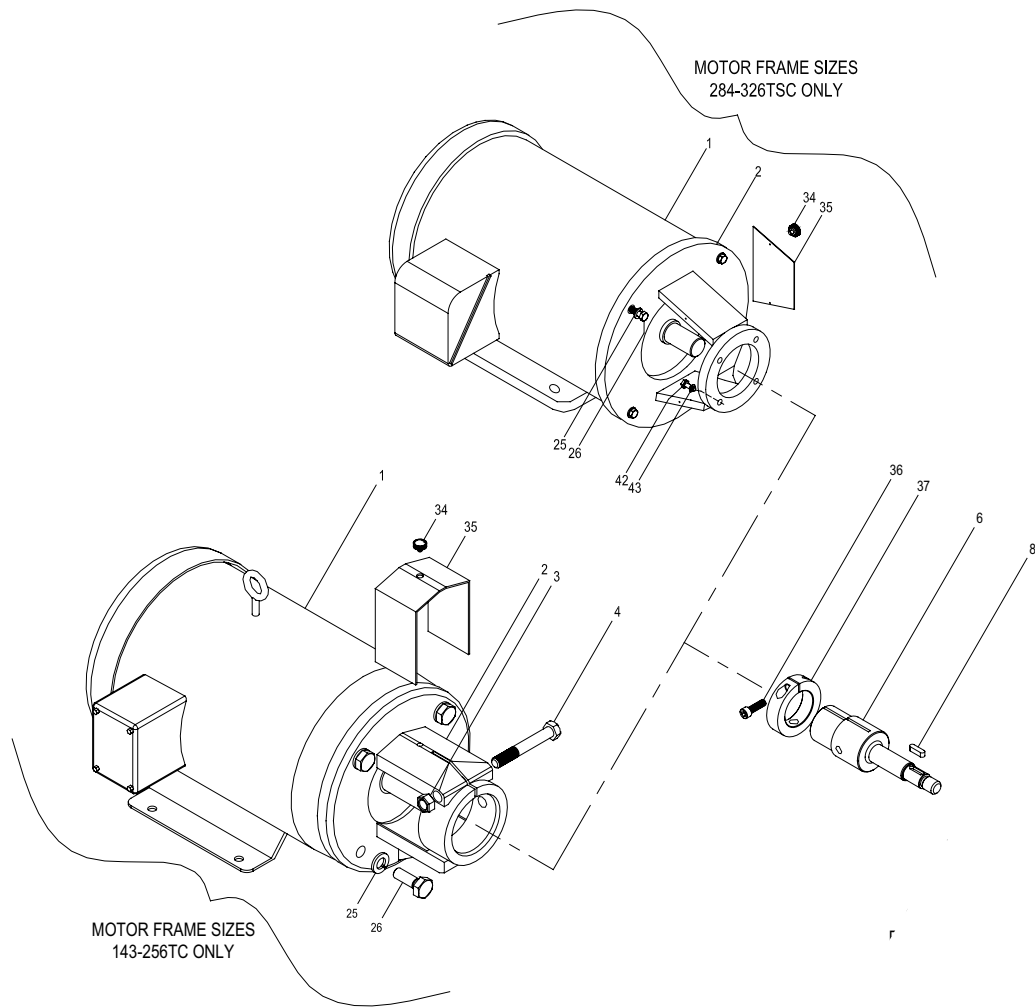
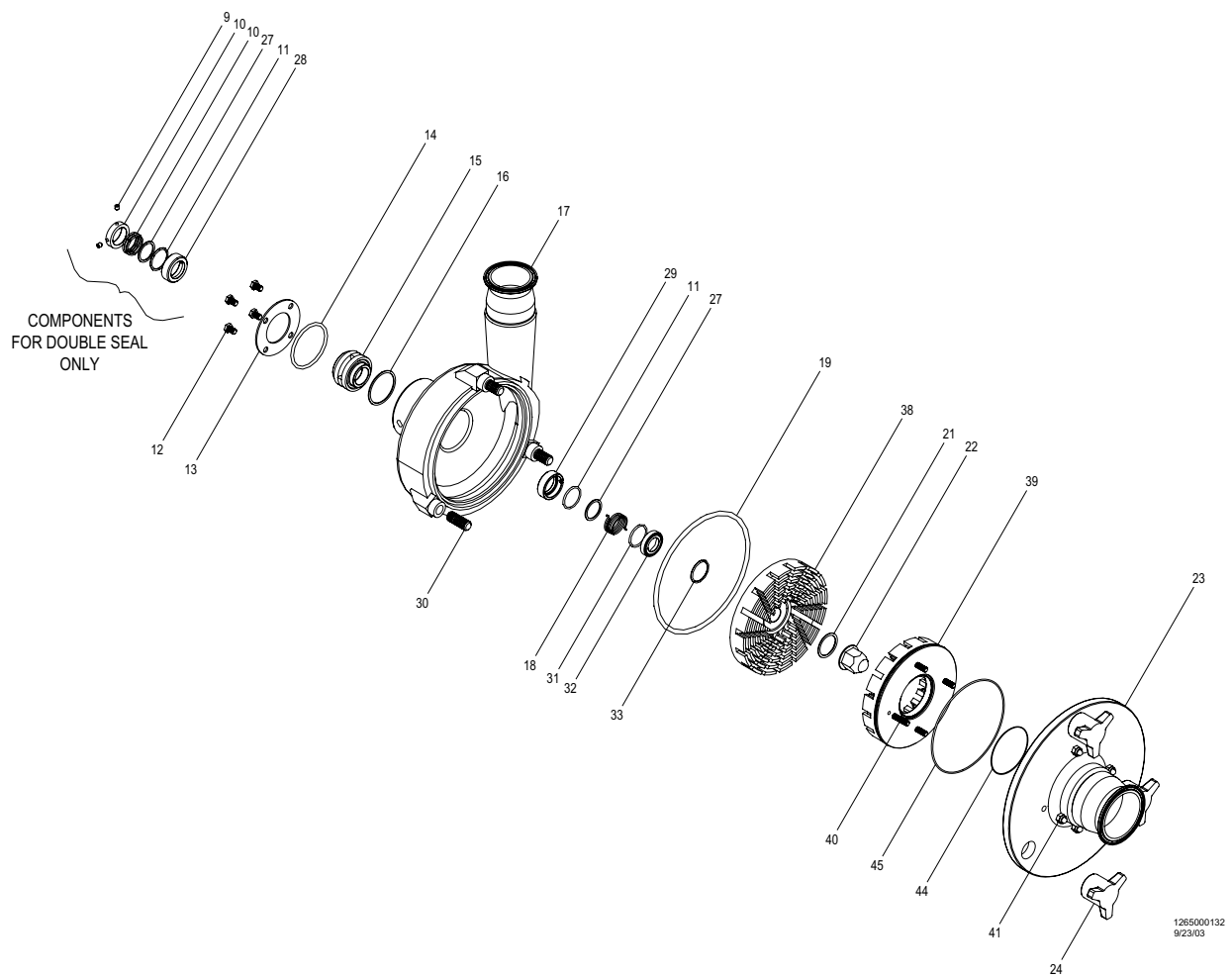

FIGURE 25: FS ASSEMBLY

- | | | | |
|-----|-----------------------------|-----|--|
| 1. | Motor | 21. | Rotor Nut Gasket |
| 2. | Flange Support | 22. | Rotor Nut |
| 3. | Clamping Bolt Nut | 23. | Pump Cover |
| 4. | Clamping Bolt | 24. | Cover Nuts |
| 6. | Pump Shaft | 25. | Lock Washer |
| 8. | Shaft Key | 26. | Motor Mounting Bolts |
| 9. | Set Screws | 27. | Rotating Seal Washer |
| 10. | Rear Seal Driver and Spring | 28. | Rear Rotating Seal |
| 11. | Rotating Seal O-ring | 29. | Rotating Seal |
| 12. | Retaining Ring Bolts | 30. | Housing Stud |
| 13. | Retaining Ring | 31. | Inside Seal Driver O-ring
(factory installed) |
| 14. | Stationary Seal O-ring | 32. | Front Seal Driver |
| 15. | Stationary Seal | 33. | Outside Seal Driver O-ring |
| 16. | Flat Gasket | 34. | Shaft Guard Screw |
| 17. | Pump Housing | 35. | Shaft Guard |
| 18. | Seal Spring | 36. | Shaft Collar Screw |
| 19. | Cover Gasket | 37. | Shaft Collar |



- 38. Rotor
- 39. Stator
- 40. Studs
- 41. Acorn nuts
- 42. Washer
- 43. Housing bolt
- 44. Inner stator o-ring
- 45. Outer stator o-ring

INSTALLATION

UNPACKING

Check the contents and all wrapping when unpacking the pump. Inspect the pump carefully for any damage that may have occurred during shipping. Immediately report any damage to the carrier. Remove the shaft guard and rotate the pump shaft by hand to make sure the rotor rotates freely. Keep the protective caps over the pump inlet and outlet in place until you are ready to install the pump.

INSTALLING

Prior to actually installing the pump, ensure that:

- the pump will be readily accessible for maintenance, inspection and cleaning.
- adequate ventilation is provided for motor cooling.
- the drive and motor type is suitable for the environment where it is to be operated. Pumps intended for use in hazardous environments e.g., explosive, corrosive, etc., must use a motor and drive with the appropriate enclosure characteristics. Failure to use an appropriate motor type may result in serious damage and/or injury.

PIPING GUIDELINES

This section describes good piping practices to obtain maximum efficiency and service life from your pump.

Maximum performance and trouble-free operation require adherence to good piping practices.

- Ensuring proper piping support and alignment at both the suction inlet and discharge outlet can help prevent serious damage to the stator (*Figure 1*).
- Avoid abrupt transitions in the piping system (*Figure 2*).
- Avoid throttling valves in the suction piping.
- Keep suction lines as short and direct as possible.
- Avoid sump areas where sediments may collect (*Figure 3*).
- Avoid the formation of air pockets in the piping (*Figure 4*).
- Avoid abrupt closure of shut-off valves, this may cause hydraulic

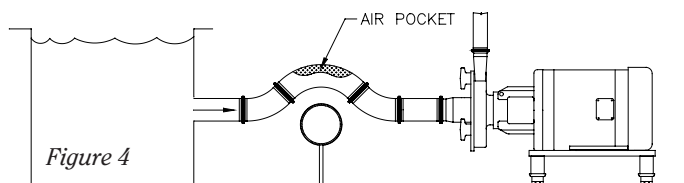
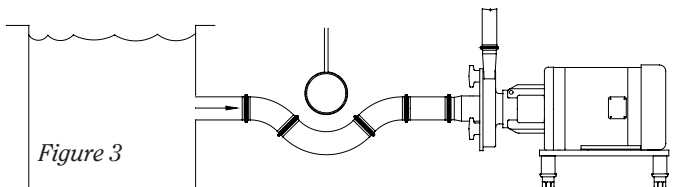
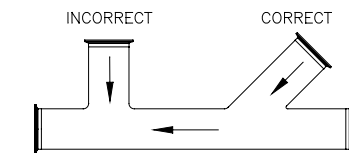
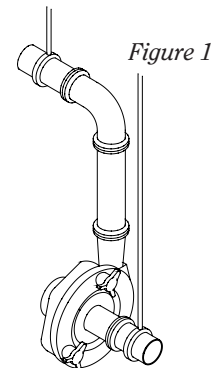

shock which can cause severe damage to the pump and system.

- Avoid elbows in the suction line if possible. When necessary they should be located 5 pipe diameters away from the pump inlet, and have a bend radius greater than 2 pipe diameters (*Figure 5*).
- Check valves in discharge line should be a minimum of 5 ft. away from the pump outlet (*Figure 5*).

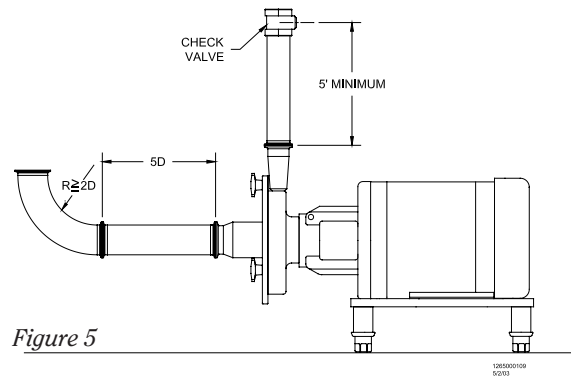

Figure 5

ELECTRICAL INSTALLATION

We use standard duty TEFC motors unless otherwise specified. Many motor options are available: wash-down, flameproof, explosion proof, hostile duty or chemical duty.

The motor selected should meet the requirements of the specified operating conditions. A change in conditions (for example, higher viscosity, higher specific gravity, lower head losses) can overload the motor. When changing operating conditions or whenever there is any doubt, please contact Fristam Pumps, Inc., for technical assistance.

Have an electrician connect the motor using sound electrical practices. Provide adequate protection. Pumps fitted with mechanical seals must not run dry, not even momentarily. *Determine the direction of rotation by watching the motor fan, which must turn clockwise.*

PUMP OPERATIONS

START-UP INSTRUCTIONS

- Remove any foreign matter that may have entered the pump.
- Do not use the pump to flush the system!

Check pump for proper rotation as indicated on the pump. *Proper motor direction is clockwise when looking at the fan end of the motor.* (NOTE: When checking the direction of rotation, the pump must be full of liquid.)

- Never run the pump dry, even momentarily. Seal damage can result.

SHUT-DOWN INSTRUCTIONS

- Shut off the power supply to the pump.
- Close the shut-off valves in the suction and discharge piping.
- Drain and clean the pump.
- Protect the pump against dust, heat, moisture and impact damage.

INSTALLATION OF WATER FLUSH FOR DOUBLE MECHANICAL SEAL

Set up the water flush for the double mechanical seal as shown (*Figure 6*). Use only between 1-2 gallons per hour of water at a maximum pressure of 5 PSI. Excessive flow of water through the seal increases the pressure inside the seal. *Note:* maximum pressure inside the seal is 5 PSI. Excessive flow/pressure through the seal flush will cause excessive wear and shorten seal life.

Pipe the exit side of the water flush with 2-5 feet physical height of tubing. This ensures that some water is always in the center seal and the seal never runs dry.

It is possible to inject steam through the center seal (within the pressure requirements). We do not recommend using steam alone for the cooling/lubricating of the seal.

It is desirable to have the flush water on the outlet side visible. This allows an easy check to see that the flush water is on and also if the seal is functioning properly. In a malfunctioning seal the flush water will disappear, become discolored, or show an unusual increase in flow. If these conditions exist, check the seal and replace if necessary.

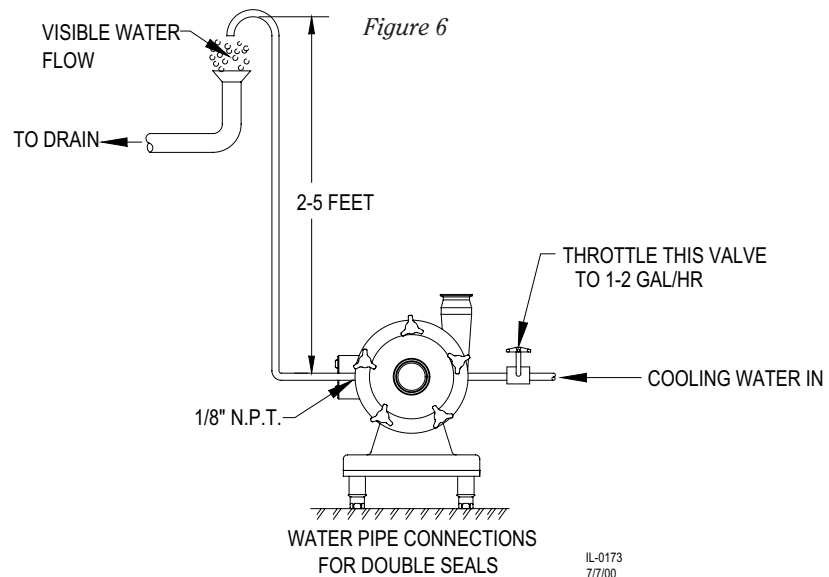

TROUBLESHOOTING

Fristam pumps are relatively maintenance free, however, in the event that a problem does arise, the troubleshooting chart below should help you with most of your pump related problems. If a motor problem arises please contact your local motor repair representative.

This troubleshooting chart has been prepared assuming that the pump installed is suitable for the application. Symptoms of cavitation can result when a pump is not properly applied. Examples of these symptoms are noisy operation, insufficient discharge, and vibration. If these conditions are present,

PROBLEM	POSSIBLE CAUSE OF TROUBLE
	(each number is defined on pages 25-26)
Pump does not deliver liquid	1, 2, 3, 4, 6, 14, 16, 17, 22, 23, 40
Not enough capacity delivered	2, 3, 4, 5, 6, 7, 8, 9, 10, 14, 16, 17, 20, 22, 23, 27, 28, 40
Not enough pressure developed	5, 6, 7, 8, 14, 16, 17, 20, 22, 27, 28, 40
Pump loses prime after starting	2, 3, 5, 6, 7, 8
Pump requires too much power	15, 17, 18, 19, 20, 23, 24, 25, 26, 27, 30, 31, 34 13, 25, 30, 31, 32, 36
Seal leaks	11, 12, 13, 25, 27, 30, 31, 32, 33, 34, 35, 36
Seal has short life	2, 3, 4, 9, 10, 21, 23, 24, 25, 26, 27, 28, 33, 34, 35, 37, 38, 39, 40
Pump vibrates or is noisy	25, 26, 27, 33, 34, 35, 37, 38, 39
Motor bearings have short life	1, 4, 21, 22, 26, 27, 33, 34, 35, 37, 38, 39, 40
Pump overheats and seizes	29
Pump leaks from cover	

SUCTION PROBLEMS

1. Pump not primed
2. Pump or suction pipe not completely filled with liquid
3. Suction lift too high
4. Insufficient difference between suction pressure and vapor pressure (cavitation)
5. Too much air or gas in liquid
6. Air pocket in suction line
7. Air leaks into suction line
8. Air leaks into pump through seal
9. Foot valve too small
10. Foot valve partially clogged
11. Seal flush water not on
12. Water seal pipe plugged
13. Seal water flush pressure too high

MECHANICAL PROBLEMS

14. Speed too low
15. Speed too high
16. Direction of rotation incorrect
17. Total head of system higher than design head of pump
18. Total head of system lower than pump design head
19. Specific gravity of liquid greater than expected
20. Viscosity of liquid greater than expected
21. Operation at very low capacity
22. Parallel operation of pumps unsuitable for

POSSIBLE SOLUTIONS

- 1a) Adjust piping so that pump is flooded
- 1b) Install a foot valve to keep liquid in the pump
2. Adjust piping so that suction pipe is filled with liquid
3. Raise the level of the liquid, lower the level of the pump
4. Use larger pipe on the inlet side of the pump, raise the level of liquid above the pump center line, lower the temperature of the liquid, eliminate fittings in suction line if possible, check inlet pipe for obstructions
5. Install air relief valve, turn pump head so discharge is at 45 degree angle
6. Adjust pipe to eliminate pocket
7. Find and fix air leak
8. Check seal for proper installation, replace seal if defective
9. Replace with larger foot valve
10. Clear obstruction from foot valve
11. Turn on water to seal flush
12. Clear obstruction from seal water pipe
13. Adjust water flow to seal flush to 1-2 gph at a maximum of 5 psi.
14. Check electrical connections, consult motor manufacturer
15. Check electrical connections, consult motor manufacturer
16. On a three-phase motor, switch any two of the three leads
17. Check for restrictions in the pipe, use larger diameter pipe, use larger diameter rotor, check application with Fristam Pumps.
18. Install throttling valve in line, use smaller diameter pipe, use smaller diameter rotor, check with Fristam Pumps.
19. Use larger motor, check application with Fristam Pumps.
20. Use larger motor, use larger diameter pipe, check application with Fristam Pumps.
21. Install throttling valve
22. Replace parallel pumps with a single larger pump

- such operation
23. Foreign matter in rotor
 24. Foundations not rigid
 25. Shaft bent
 26. Rotor rubbing on stator
 27. Motor bearings worn
 28. Rotor damage
 29. Cover gasket defective permitting leakage
 30. Shaft or shaft collar worn or scored
 31. Seal improperly installed
 32. Type of seal incorrect for operating conditions
 33. Pump shaft running off center because of worn bearings or misalignment
 34. Rotor out of balance causing vibration
 35. Motor front bearing not locked
 36. Dirt or grit in sealing liquid, leading to scoring of shaft or seal surface
 37. Lack of lubrication in motor bearing
 38. Improper installation of antifriction bearings (damage during assembly, incorrect assembly of stacked bearings, use of unmatched bearings as a pair, etc.)
 39. Dirt in bearings
 40. Piping is obstructed
 23. Remove pump cover and clear foreign matter
 24. Provide firmer foundation for the pump
 25. Replace shaft
 26. Re-establish gap of the rotor, replace rotor if defective, make sure rotor nut is tightened properly, check TIR of pump shaft
 27. Replace motor bearings
 28. Replace rotor
 29. Replace cover gasket
 30. Replace pump shaft and/or collar
 31. Install seal correctly, replace seal if defective
 32. Replace seal with correct type of seal, check with your local representative
 33. Check motor bearings and replace if defective, indicate the pump shaft to .002" TIR
 34. Balance the rotor
 35. Contact motor manufacturer for locking shim or to replace motor with a motor with locked front bearing
 36. Use clean source of water for seal flush
 37. Lubricate motor bearings
 38. Reinstall bearings correctly
 39. Clean bearings, replace if defective
 40. Remove obstruction in pipe, check for closed valve

PUMP MAINTENANCE RECORD

Date	Service Performed	By

PUMP MAINTENANCE RECORD

Date	Service Performed	By

NOTES

NOTICE OF TERMS, WARRANTY PROVISIONS INCLUDING DISCLAIMERS, CLAIMS AND LIMITATION OF LIABILITY

Prices and all terms and conditions of sale are established in current price sheets and are subject to change without notice. All orders are subject to acceptance by Fristam Pumps USA Limited Partnership.

Each Fristam Pumps item is warranted to be free from manufacturing defects for a period of one (1) year from the date of shipment, providing it has been used as recommended and in accordance with recognized piping practice, and providing it has not been worn out due to severe service, such as encountered under extremely corrosive or abrasive conditions.

This warranty is expressly in lieu of any other warranties expressed or implied, including but not limited to, any implied warranty of merchantability or fitness for particular purpose. All other warranties whatsoever, expressed or implied by law or otherwise, are hereby excluded.

All claims must be in writing and must be mailed or delivered by purchaser within thirty (30) days after purchaser learns of the facts upon which such claim is based. Any claim not made in writing and within the time period specified above shall be deemed waived.

Purchaser's sole and exclusive remedy and Fristam Pumps's maximum liability for claims arising hereunder or for negligence for any and all losses and damages resulting from any cause shall be either the repair or replacement of defective items or, at Fristam Pumps' option, the refund of the purchase price for such items. In no event, including in the case of a claim for negligence, shall Fristam Pumps be liable for incidental or consequential damages, including loss of profits.

No person, including any representative employee or agent of Fristam Pumps is authorized to assume on behalf of Fristam Pumps any liability or responsibility in addition to or different from that described in this provision. Any and all representations, promises, warranties or statements that are in addition to or different from the terms of this provision are of no force or effect.

If any provision of this Notice is held to be invalid, such provision shall be severed and the remaining provisions shall continue to be in force.



© Copyright 2011 - Fristam Pumps USA Limited Partnership
Drawing # 125000014 Rev - Updated 6/3/2011
Part # 105000039
Visit www.fristam.com for a current list of literature.

2410 Parview Road • Middleton, WI 53562-2524
1-800-841-5001 • 608-831-5001
www.fristam.com
Email: fristam@fristampumps.com