



INSTRUCTION AND MAINTENANCE MANUAL: FS SERIES SHEAR BLENDER



SANITARY MIXING AND BLENDING EQUIPMENT

DESCRIPTION

This manual contains installation, operation, assembly, disassembly and repair instructions for the Fristam FS Shear Blender.

The motors are standard NEMA totally enclosed fan cooled (TEFC) motors. They are C-face and have a locked front bearing. These motors do not require feet. Replacement motors are easily available from local motor distributors.

SAFETY

This instruction and maintenance manual shall be read and completely understood prior to operation of the pump. The manual should be kept available at the pump installation location.

All applicable local/national regulation and laws shall be followed.

All work described herein may only be performed by qualified personnel.

Personal protective equipment (PPE) such as hearing protection may be required.

Despite inherent safe design measures some amount residual risk will remain. Throughout the manual these risks will be pointed out.

CAUTION

Begin all pump maintenance operations by disconnecting the energy source to the pump. Observe all lock out/tag out procedures as outlined by ANSI Z244.1-1982 and OSHA 1910.147 to prevent accidental start-up and injury.

TABLE OF CONTENTS

Technical Information.....	4
Preventative Maintenance.....	6
Installation.....	7
Assembly Drawings: 757/758 Seal.....	10
Assembly Drawings: 857/858 Seal.....	12
Exploded Pump Assembly Drawings.....	14
Seal Replacement	16
Pump Shaft Replacement.....	23
Setting Rotor-to-Stator Gap.....	25
Setting Shaft Alignment.....	27
Motor Replacement	28
Maintenance Record.....	29
Warranty	31

TECHNICAL INFORMATION

SPECIFICATIONS

Maximum Inlet Pressure.....	80 PSI - Close Coupled
.....	150 PSI - Bearing Block
Temperature Range	-40oF – 400oF
Noise Level.....	60 – 85 dB (A)

STANDARD MATERIALS OF CONSTRUCTION (NOTE: OTHER OPTIONS AVAILABLE)

STANDARD MATERIALS OF CONSTRUCTION (NOTE: OTHER OPTIONS AVAILABLE)

Product Contact Components.....	AISI 316L Stainless Steel
Seal Components	
Rotating Seal	Chrome Oxide coated 316L Stainless Steel
Stationary Seal	Silicon Carbide
Flush Seal (if installed)	Ceramic
Product Contact Surface Finish.....	32 in Ra
Flange Support	Cast Iron
Gaskets / O-rings	Viton
Cover and Stator O-rings	Buna
Motor	NEMA TEFC C-face (Painted Rolled Steel or Painted Cast Iron)
.....	3 Phase, 60 Hz, 208-230/460 VAC, 1750/3500 RPM

FRONT PULL-OUT SEAL OPTIONS

Single Internal Mechanical	
Single Internal Mechanical with Cascade	
Single Internal Mechanical with Double External Mechanical	
Recommended Seal Flush Pressure.....	5 PSI Maximum
Recommended Seal Flush Flow.....	1 –2 Gallons per Hour

SEAL SIZES

757/857	Used on Models: 710, 720, 3520, 3530, & 3540
.....	Motor Frame Range: 140TC – 320TC, Single Flange
758/858	Used on Model: 3550 & 3540
.....	Motor Frame Range: 180TC—360TC, Double Flange

RECOMMENDED TORQUE VALUES

Rotor Nut	40 ft-lbs
Stator Nut	65 in-lbs
Cover Hex Nut	45 ft-lbs
757 Housing Clamp Bolt	55 ft-lbs
758 Housing Bolts	50 ft-lbs
Motor Bolts	
56C – 140TC	20 ft-lbs
180TC – 280TSC	55 ft-lbs
320TC – 360TC	110 ft-lbs
Shaft Collar Screw(s)	
56C – 140TC	12 ft-lbs
180TC – 280TSC	24 ft-lbs
280TC – 360TSC	43 ft-lbs

ROTOR-TO-STATOR GAPS

All models	0.5 mm (0.020")
------------------	-----------------

SHAFT RUN-OUT TOLERANCE

All models	0.05 mm (0.002")
------------------	------------------

TOOLS FOR ASSEMBLY & DISASSEMBLY

10 mm socket	stator nuts
9/16" socket	56C – 140TC motor bolts
3/4" socket	180TC – 280TC motor bolts, double flange housing bolts
.....	Single flange housing clamp bolt
15/16" socket	Rotor nut, 320TC – 360TC motor bolts
3/16" Allen wrench socket.....	56C – 180TC shaft collars
1/4" Allen wrench socket.....	210TC – 250TC shaft collars
5/16" Allen wrench socket.....	280TC – 360TSC shaft collars
3/4" wrench.....	Single flange clamp bolt
1/2" wrench.....	For forcing screw (if hex bolt type)
Ratchet	For loosening bolts
Torque wrench.....	For proper tightening
Adjustable pliers	For removing water pipes
Soft-faced hammer	For removing cover star nuts
1" socket.....	For cover hex nuts
3/8" diameter rod.....	For holding the shaft when tightening & loosening the rotor
Food grade lubricant.....	For lubricating O-rings and gaskets
Gapping Shims .5mm/.020"	Model 710 (part# 1373000089)
.....	Model 3520-3530 (part# 1373000062)
.....	Model 3540-3550 (part# 1373000063)

RECOMMENDED PREVENTIVE MAINTENANCE

RECOMMENDED SEAL MAINTENANCE

Visually inspect mechanical seal daily for leakage. Replace mechanical seal annually under normal duty. Replace mechanical seal as often as required under heavy duty.

ELASTOMER INSPECTION

Inspect all elastomers when performing pump maintenance. We recommend replacing elastomers (O-rings and gaskets) during seal, pump shaft and/or motor replacement.

PUMP SHAFT INSPECTION

Inspect the pump shaft and collar annually for wear. Inspect the shaft collar bolt(s) annually or more often in corrosive environments.

CLEANING RECOMMENDATIONS

The FS Shear Blender is designed for CIP (clean-in place) cleaning. It is not necessary to disassemble the blender for cleaning in most applications. For sticky products the blender should be rinsed after the process is complete to prevent the blender components from sticking together and causing damage.

The blender should be run at a minimum of 1,000 rpm for cleaning. The blender can be run at reduced speed during CIP. If the blender is run too fast, flow will be restricted through the blender and it will cavitate. Excessive cavitation will cause component damage. For proper cleaning the flow must go forward through the blender. Do not clean the blender with reverse flow.

MOTOR LUBRICATION RECOMMENDATIONS

Use a high grade ball and roller bearing grease. (See Tables 1-3 for more details.) Please consult the motor manufacturers' recommendations for lubrication.

*Table 1: Motor Lubrication Intervals for Standard Conditions**

Frame Size: NEMA (IEC)	3500 RPM	1750 RPM
Up to 210 incl. (132 IEC)	5,500 hrs.	12,000 hrs.
Over 210 to 280 incl. (180 IEC)	3,600 hrs.	9,500 hrs.
Over 280 to 360 incl. (225 IEC)	2,200 hrs.	7,400 hrs.

*For severe conditions, multiply interval hours by 0.5; for extreme conditions, multiply interval hours by 0.1

Table 2: Service Conditions Definitions

Service Conditions	Max. Ambient Temperature	Atmospheric Contamination
Standard	104°F (40°C)	Clean, little corrosion
Severe	122°F (50°C)	Moderate dirt, corrosion
Extreme	>122°F (50°C)	Severe dirt, abrasive dust, corrosion

Table 3: Volume of Grease to be Added per Bearing

Frame Size NEMA (IEC)	Grease IN ³	Volume TSP
Up to 210 incl. (132 IEC)	0.6	2.0
Over 210 to 280 incl. (180 IEC)	1.2	3.9
Over 280 to 360 incl. (225 IEC)	1.5	5.2

INSTALLATION

UNPACKING

Check the contents and all wrapping when unpacking the pump. Inspect the pump carefully for any damage that may have occurred during shipping. Immediately report any damage to the carrier. Remove the shaft guard and rotate the pump shaft by hand to make sure the rotor rotates freely. Keep the protective caps over the pump inlet and outlet in place until you are ready to install the pump.

INSTALLING

Prior to actually installing the pump, ensure that:

- The pump will be readily accessible for maintenance, inspection and cleaning.
- Adequate ventilation is provided for motor cooling.
- The drive and motor type is suitable for the environment where it is to be operated. Pumps intended for use in hazardous environments (i.e. explosive, corrosive, etc.) must use a motor and drive with the appropriate enclosure characteristics. Failure to use an appropriate motor type may result in serious damage and/or injury.

PIPING GUIDELINES

This section describes good piping practices to obtain maximum efficiency and service life from your pump.

Maximum performance and trouble-free operation require adherence to good piping practices.

- Ensuring proper piping support and alignment at both the suction inlet and discharge outlet can help prevent serious damage to the pump housing (Figure 23).
- Avoid abrupt transitions in the piping system (Figure 24).
- Avoid throttling valves in the suction piping.
- Keep suction lines as short and direct as possible.
- Ensure that the NPSH available in the system is greater than NPSH required by the pump.
- Avoid sump areas where sediments may collect (Figure 25).

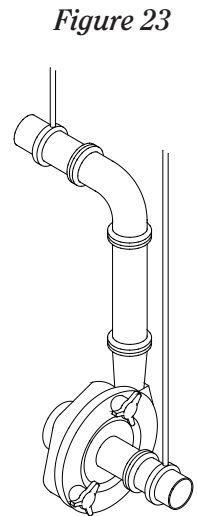

Figure 23

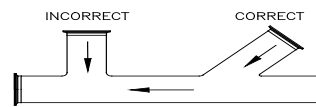

Figure 24

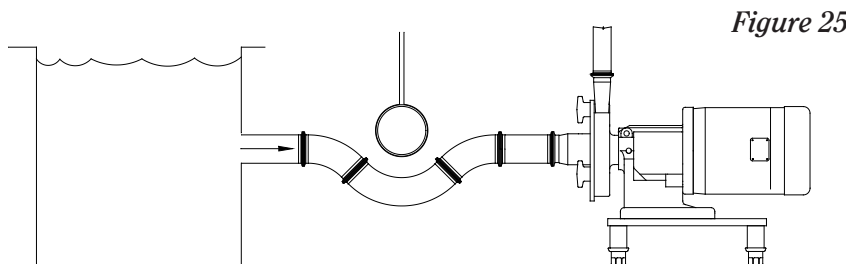
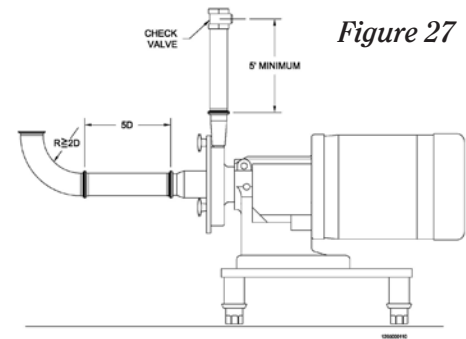
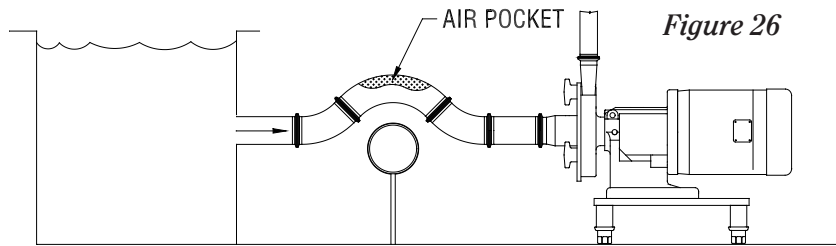

Figure 25

- Avoid the formation of air pockets in the piping (Figure 26).
- Avoid abrupt closure of shut-off valves, this may cause hydraulic shock which can cause severe damage to the pump and system.
- Avoid elbows in the suction line if possible. When necessary they should be located 5 pipe diameters away from the pump inlet, and have a bend radius greater than 2 pipe diameters (Figure 27).
- Check valves in discharge line should be a minimum of 5 ft. away from the pump outlet (Figure 27).



ELECTRICAL INSTALLATION

We use standard duty TEFC motors unless otherwise specified. Many motor options are available: washdown, flameproof, explosion proof, hostile duty or chemical duty.

The motor selected should meet the requirements of the specified operating conditions. A change in conditions (for example, higher viscosity, higher specific gravity, lower head losses) can overload the motor. When changing operating conditions or whenever there is any doubt, please contact Fristam Pumps, Inc., for technical assistance.

Have an electrician connect the motor using sound electrical practices. Provide adequate protection. Pumps fitted with mechanical seals must not run dry, not even momentarily. Determine the direction of rotation by watching the motor fan, which must turn clockwise.

PUMP OPERATIONS

START-UP INSTRUCTIONS

- Remove any foreign matter that may have entered the pump.
- Do not use the pump to flush the system!
- Check pump for proper rotation as indicated on the pump. **Proper motor direction is clockwise when looking at the fan end of the motor.** (NOTE: When checking the direction of rotation, the pump must be full of liquid.)
- Never run the pump dry, even momentarily. Seal damage can result.

SHUT-DOWN INSTRUCTIONS

- Shut off the power supply to the pump.
- Close the shut-off valves in the suction and discharge piping.
- Drain and clean the pump.
- Protect the pump against dust, heat, moisture and impact damage.

INSTALLATION OF WATER FLUSH FOR DOUBLE MECHANICAL SEAL

Set up the water flush for the double mechanical seal as shown (Figure 28). Use only between 1-2 gallons per hour of water at a maximum pressure of 5 PSI. Excessive flow of water through the seal increases the pressure inside the seal. Note: maximum pressure inside the seal is 5 PSI. Excessive flow/pressure through the seal flush will cause excessive wear and shorten seal life.

Pipe the exit side of the water flush with 2-5 feet physical height of tubing. This ensures that some water is always in the center seal and the seal never runs dry.

It is possible to inject steam through the center seal (within the pressure requirements). We do not recommend using steam alone for the cooling/lubricating of the seal.

It is desirable to have the flush water on the outlet side visible. This allows an easy check to see that the flush water is on and also if the seal is functioning properly. In a malfunctioning seal the flush water will disappear, become discolored, or show an unusual increase in flow. If these conditions exist, check the seal and replace if necessary.

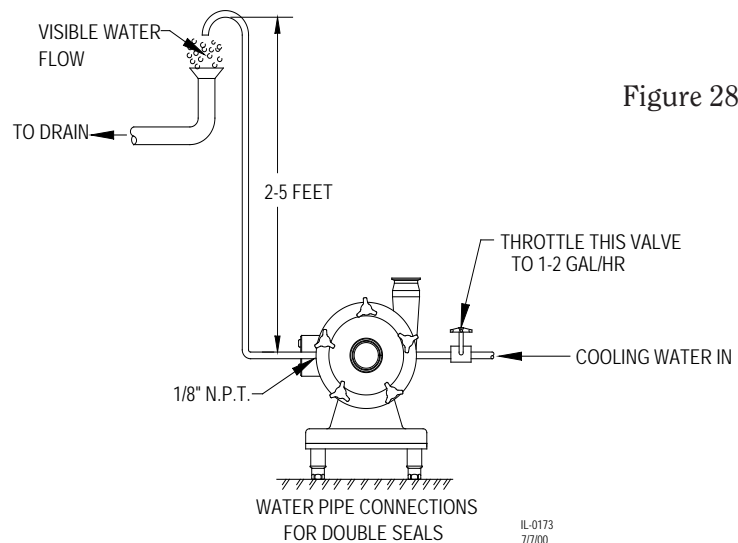

Figure 28

INSTALLATION OF WATER CASCADE

The water cascade (if supplied) is piped through the hub of the pump housing and into the stationary seal. Since there is no rear seal, the flush water will exit through the rear of the seal area (Figure 29).

Not all FPR pumps require a water cascade on the seal.

Use about 1-2 gallons per hour of water at a maximum pressure inside the seal of 5 psi.

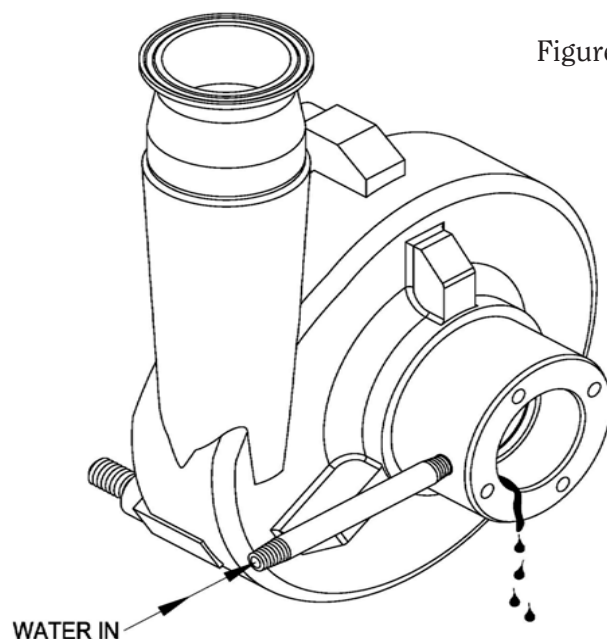
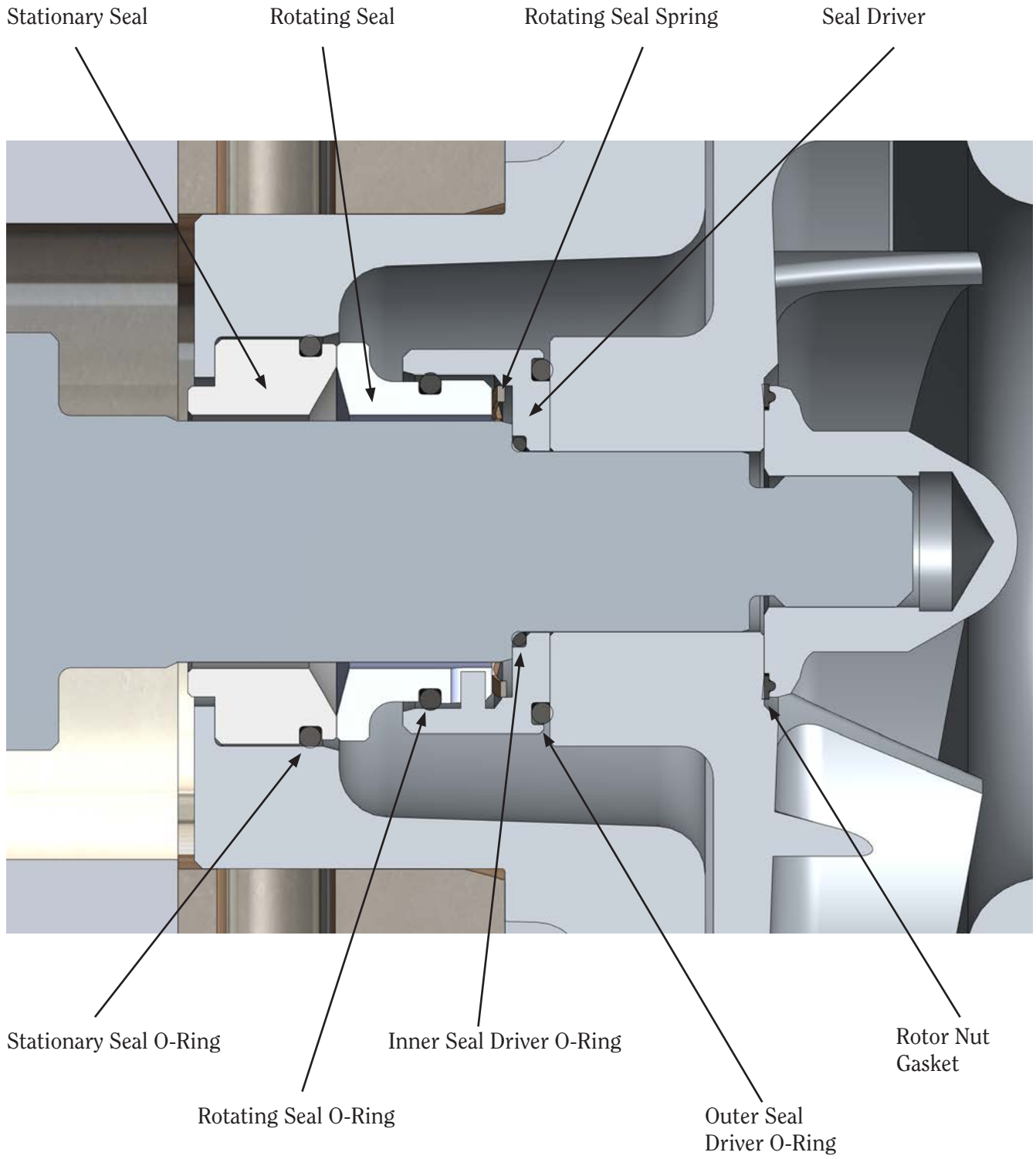
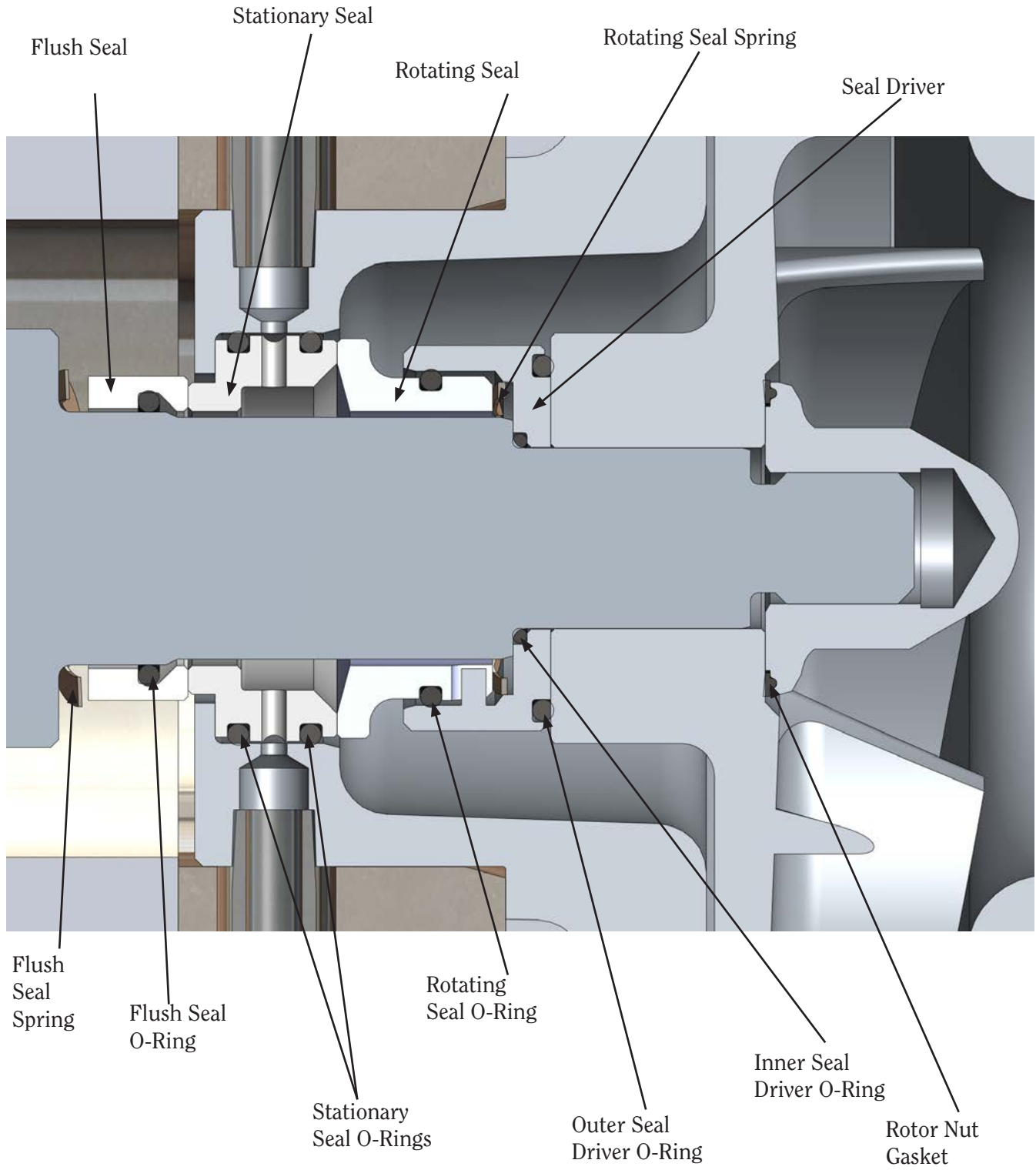

Figure 29

SINGLE SEAL ASSEMBLY (757/758)



DOUBLE SEAL ASSEMBLY (757/758)



SINGLE SEAL ASSEMBLY (SIZES 857/858, COIL SPRING)

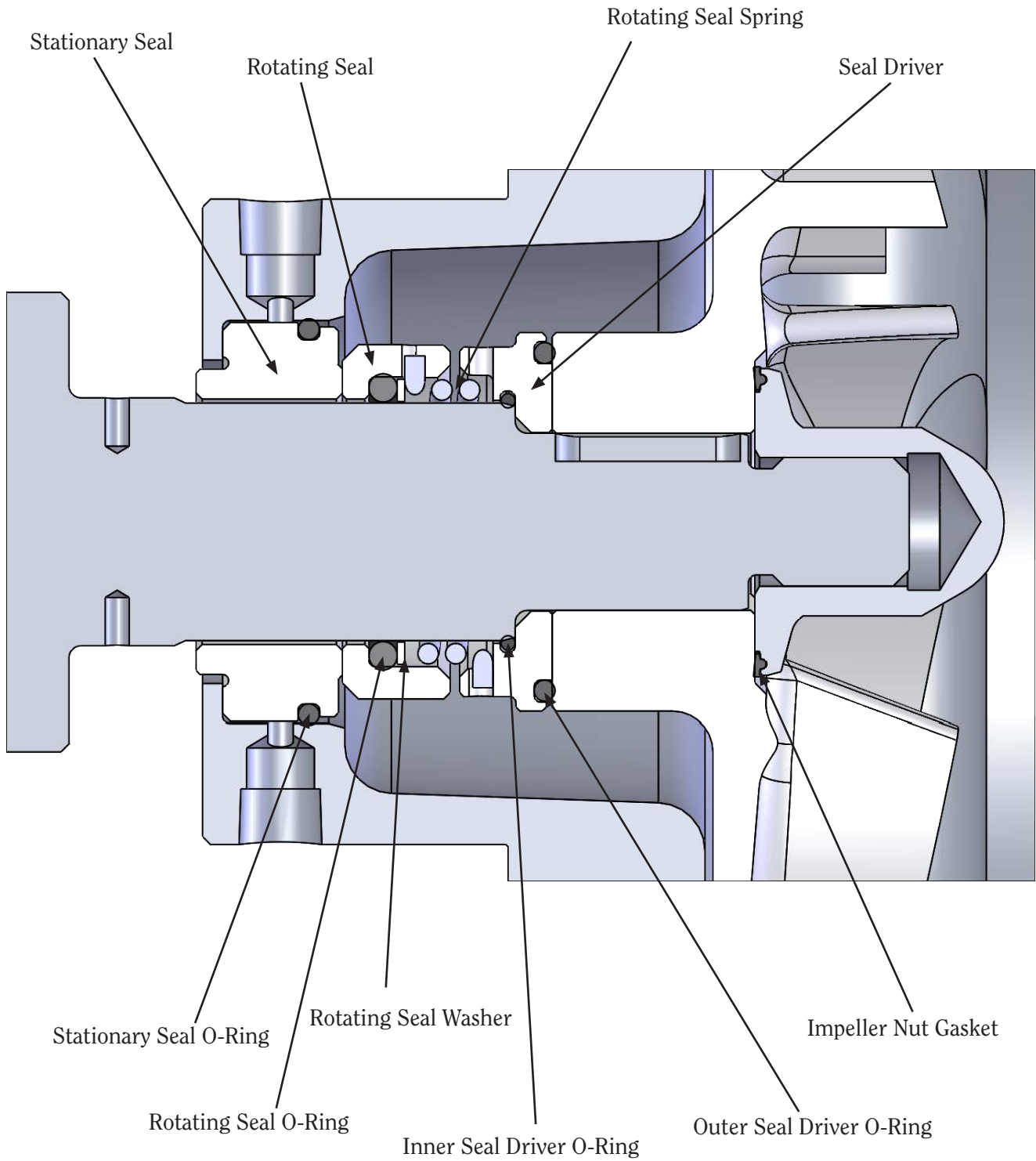

DOUBLE SEAL ASSEMBLY (SIZES 857/858, COIL SPRING)

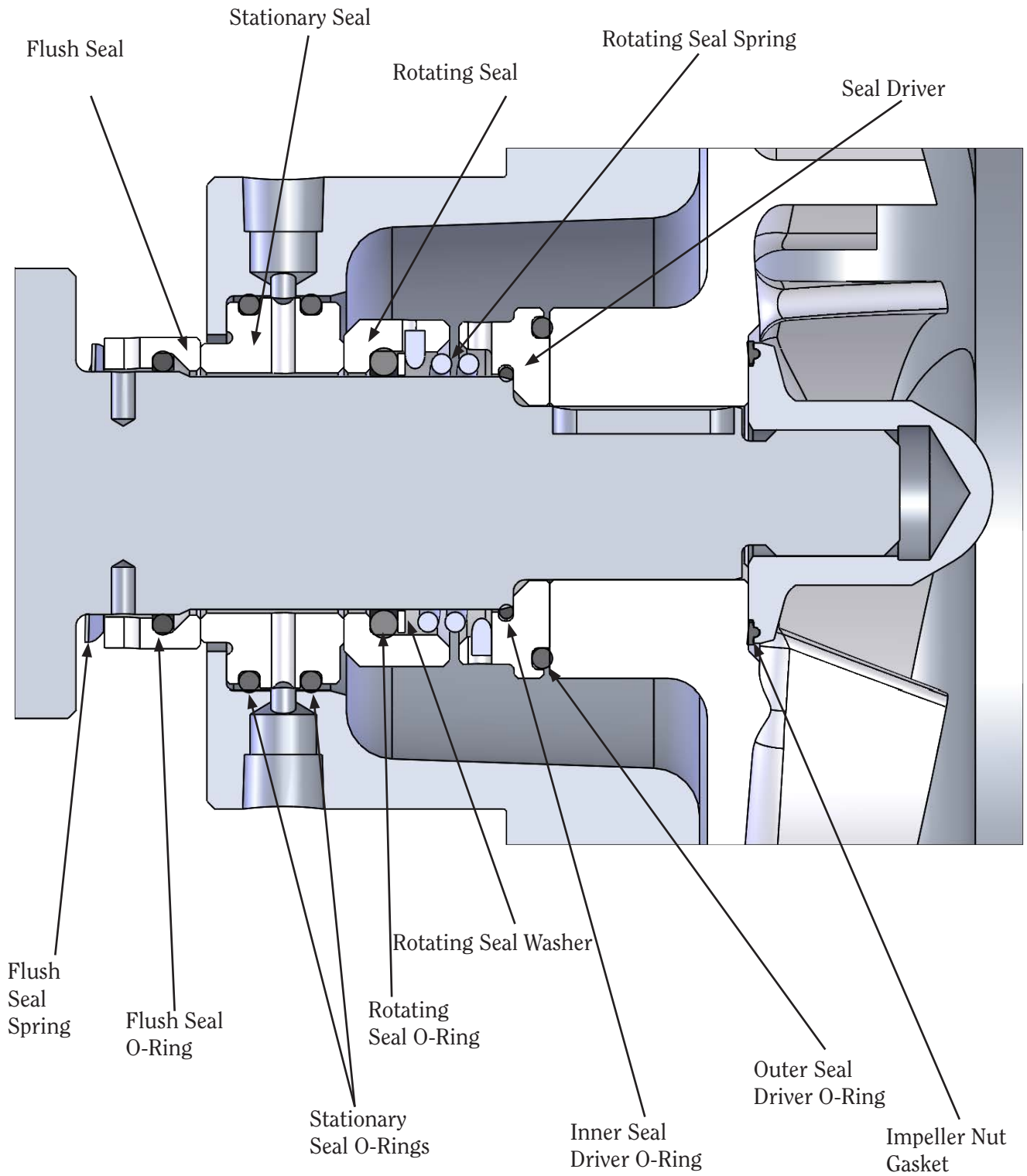

EXPLODED ASSEMBLY
SINGLE FLANGE

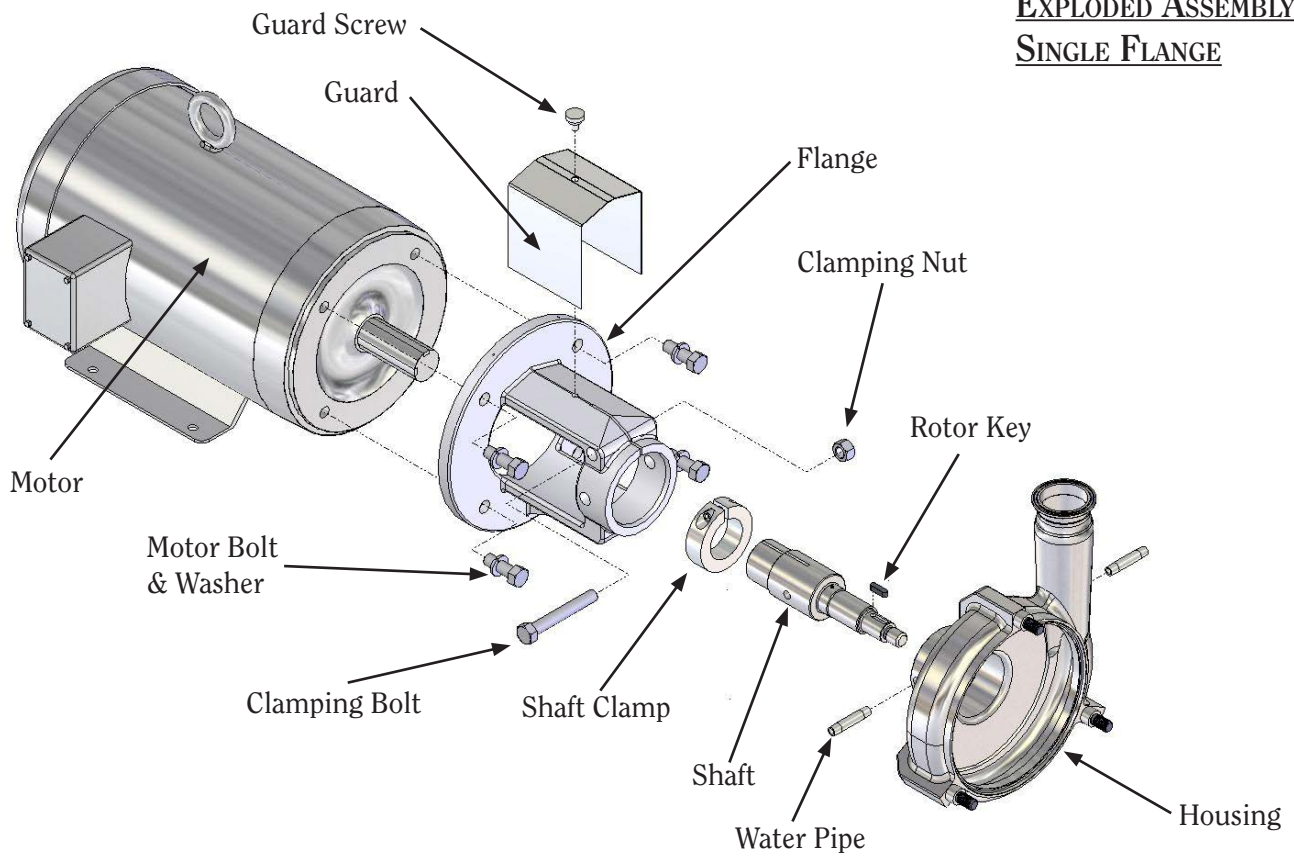

EXPLODED ASSEMBLY
DOUBLE FLANGE

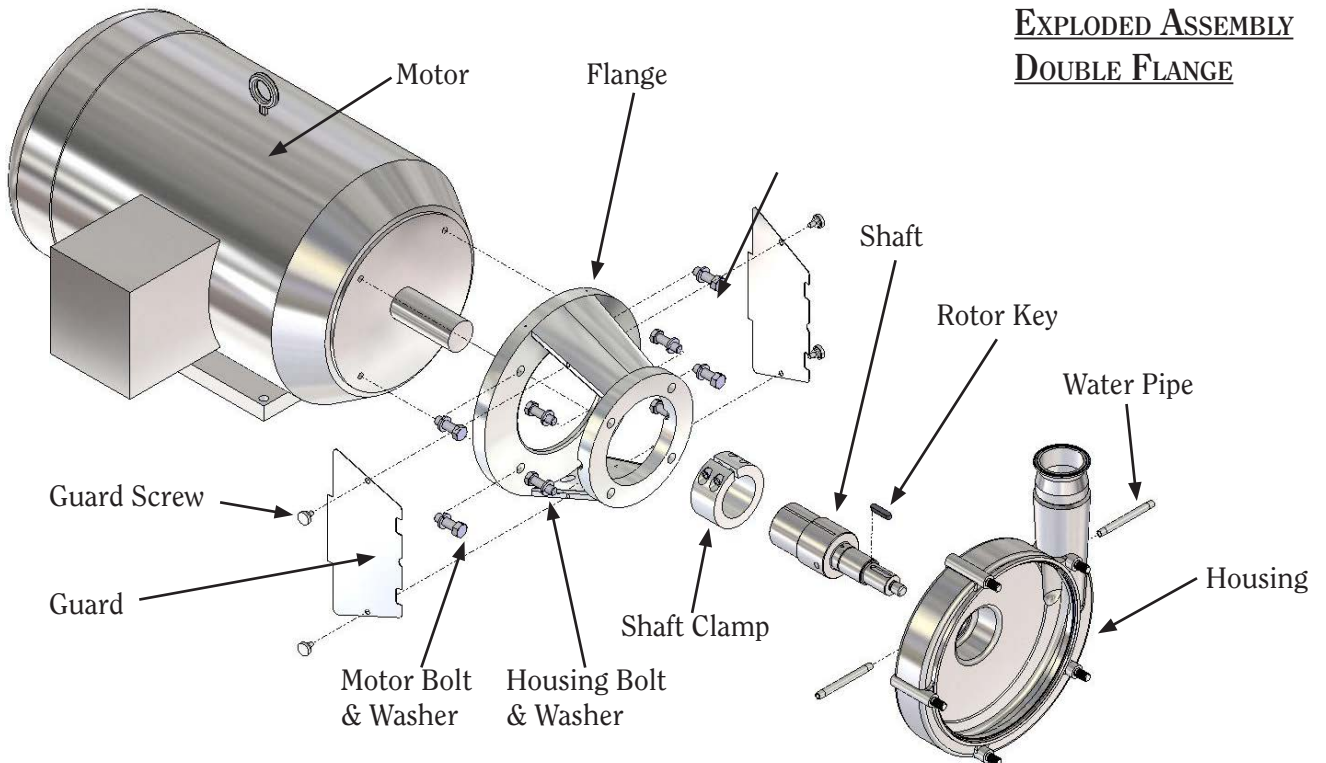

Coil spring option 857

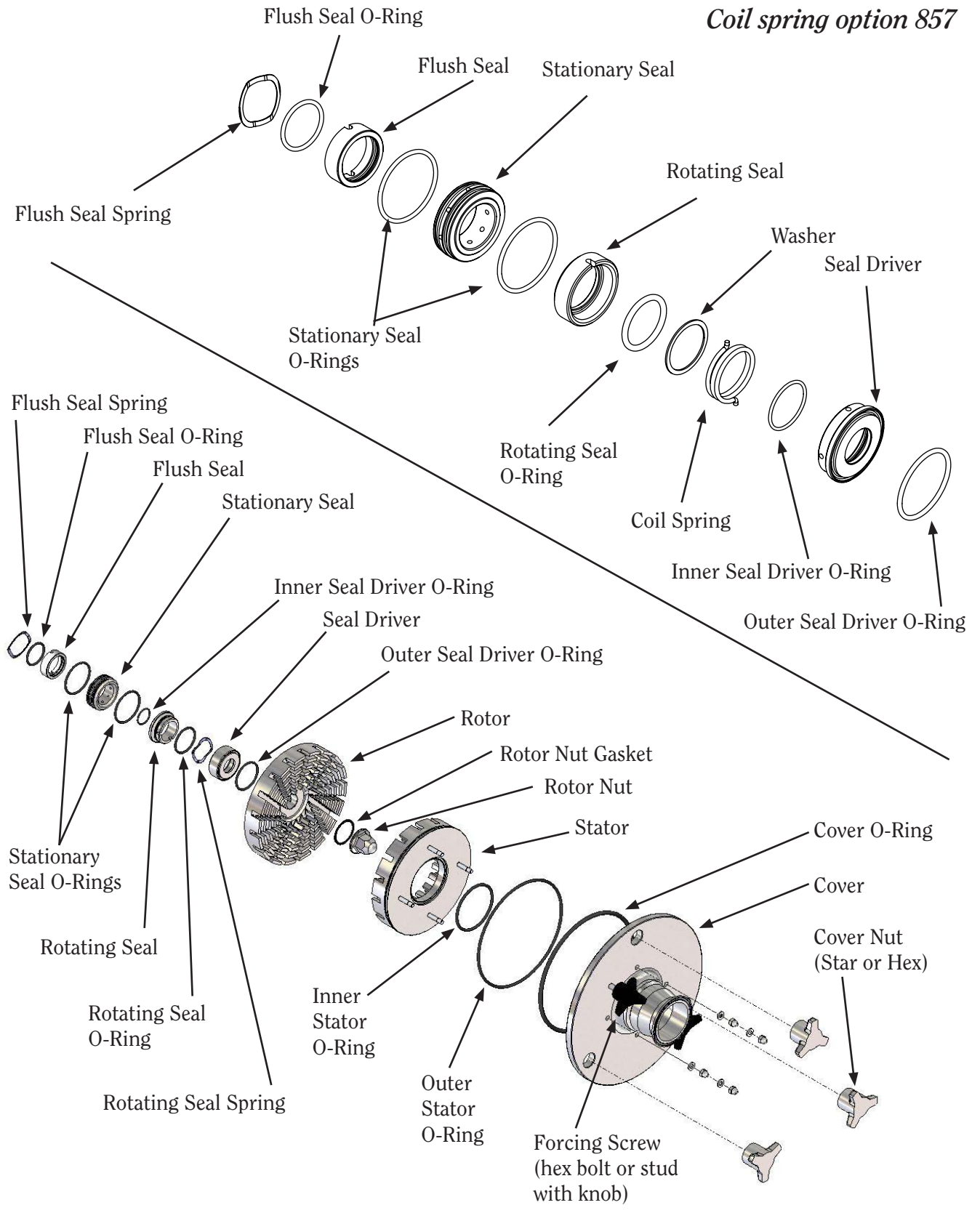

SEAL REPLACEMENT

DISASSEMBLY

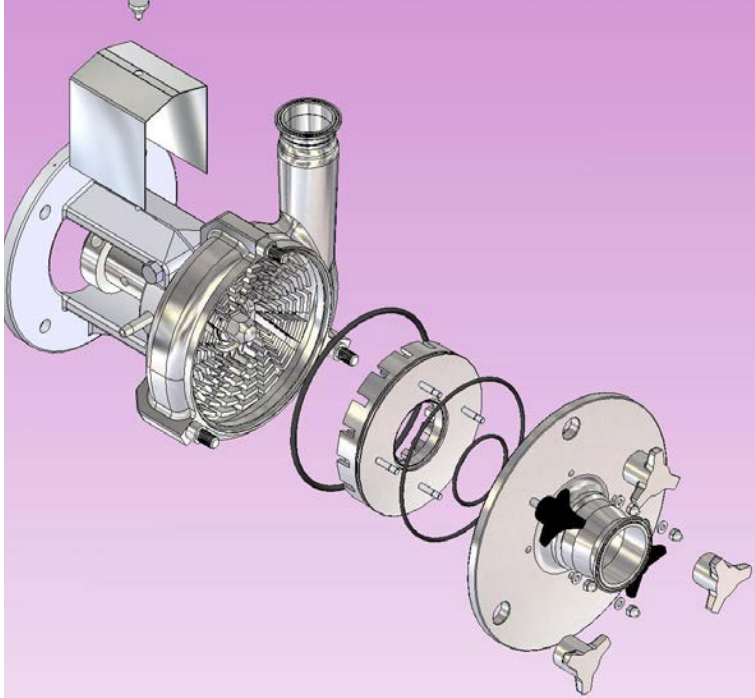

Note: When replacing ANY seal part, it is important that ALL seal wear parts are replaced to ensure seal integrity.

Figure 1

Remove flange guard.

Remove cover nuts.

Remove cover and discard cover O-ring.

Remove the stator from the cover by turning the forcing screws clockwise to free the stator from the cover. Remove and discard the stator O-rings.

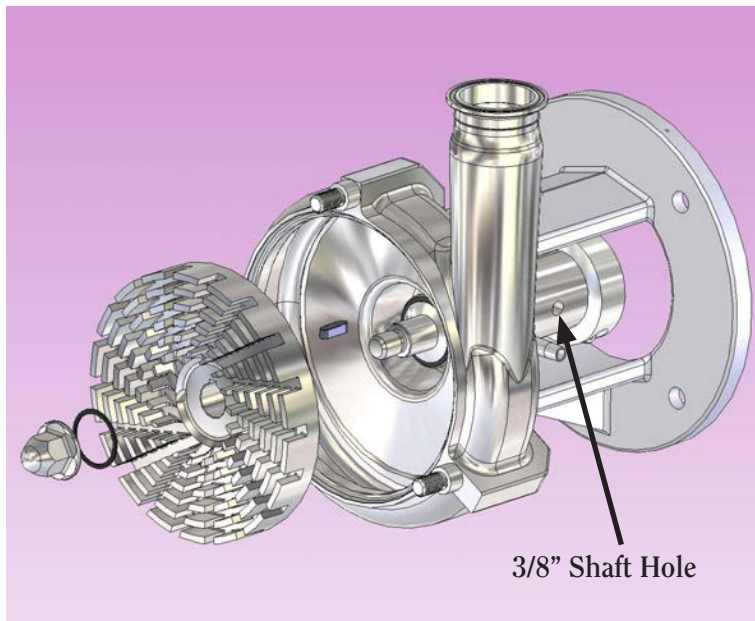

Figure 2

Place 3/8" rod or Phillips screwdriver in shaft hole. Remove rotor nut. Discard rotor nut gasket.

Remove rotor and discard rotor O-ring.

You may need to insert two long rods or screwdrivers into the holes in the rotor to remove it.

Remove the rotor key.

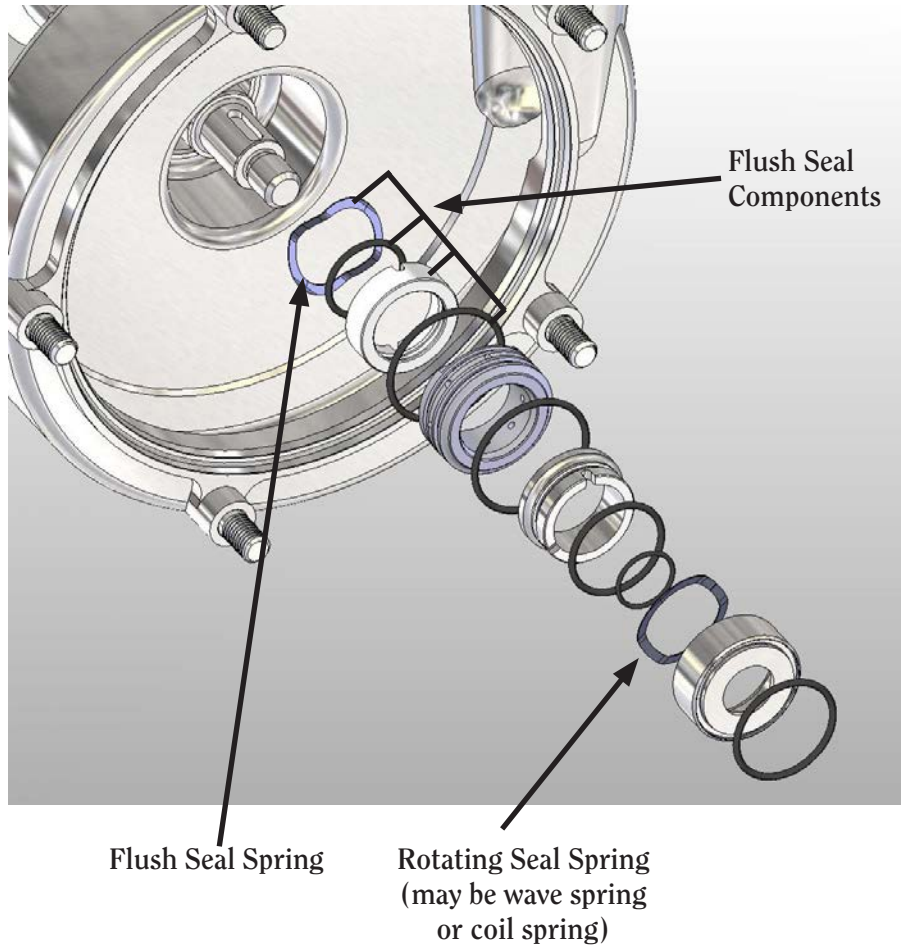

Figure 3

Remove seal driver/rotating seal assembly.

Discard rotating seal, O-rings and spring. Do not discard the seal driver.

Remove and discard the stationary seal and its O-rings.

Double Seal Only: Remove flush seal and flush seal spring and discard.

(Note: to distinguish between the seal springs: FLUSH SEAL SPRING HAS A WHITE STRIPE ON THE OUTSIDE EDGE; ROTATING SEAL SPRING DOES NOT.)

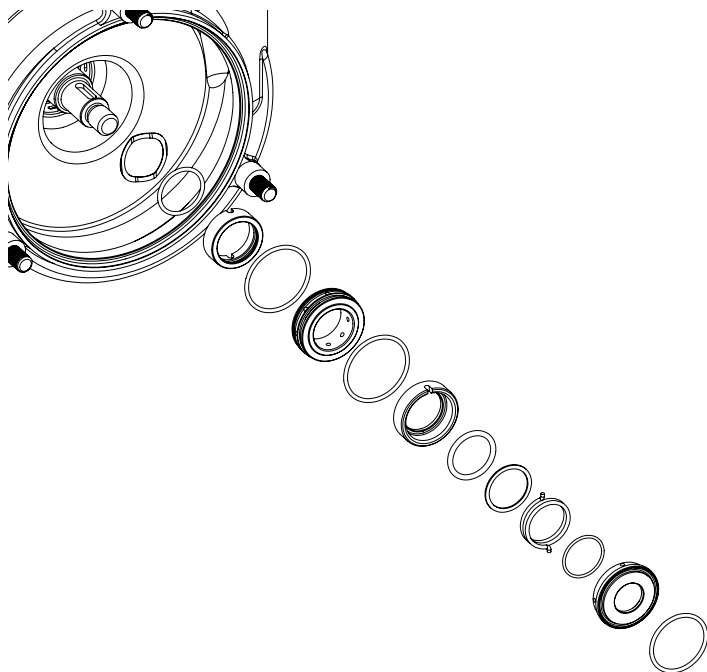

ASSEMBLY (ALL MODELS EXCEPT 4001)

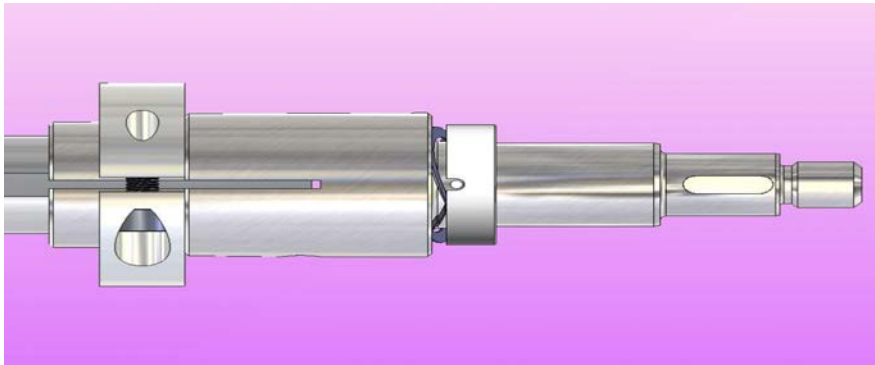

FLUSH SEAL
(if pump has double seal)

Figure 4

Install spring behind shaft pins. Place o-ring into double rotating seal and lubricate. Push seal onto shaft making sure slots align with pins.

(Note: housing and flange removed from picture for clarity)

Stationary Seal O-ring
(single seal)

Stationary Seal O-rings
(double seal)

Figure 5

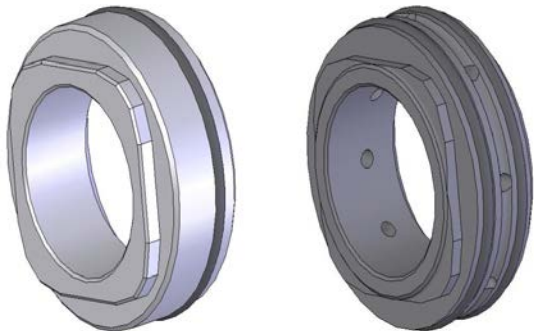

Single Seal:
Install single stationary seal O-ring and lubricate.

Double Seal:
Install single and double stationary seal O-rings and lubricate.

Align flats on
housing & seal

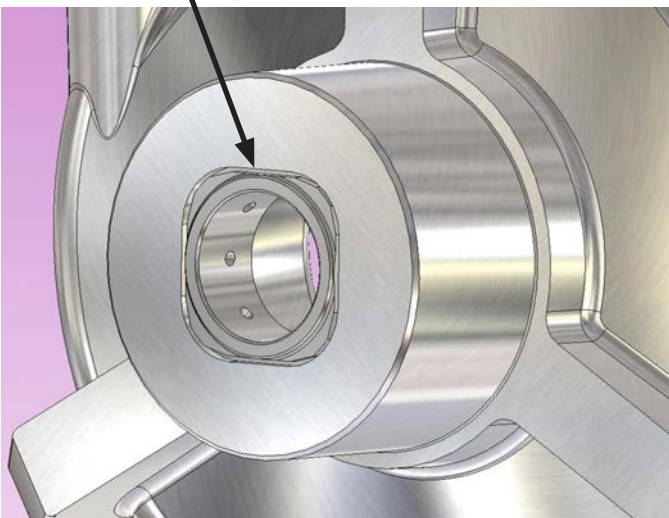

Figure 6

Install the stationary seal into housing making sure to align flats on the seal with the flats on the housing.



Figure 7

Install spring behind seal pins inside the seal driver.



Figure 8

Install single rotating seal O-ring and lubricate. Slide seal driver onto rotating seal making sure to align pins inside the driver with the slots on the seal.

Inner Seal Driver O-ring

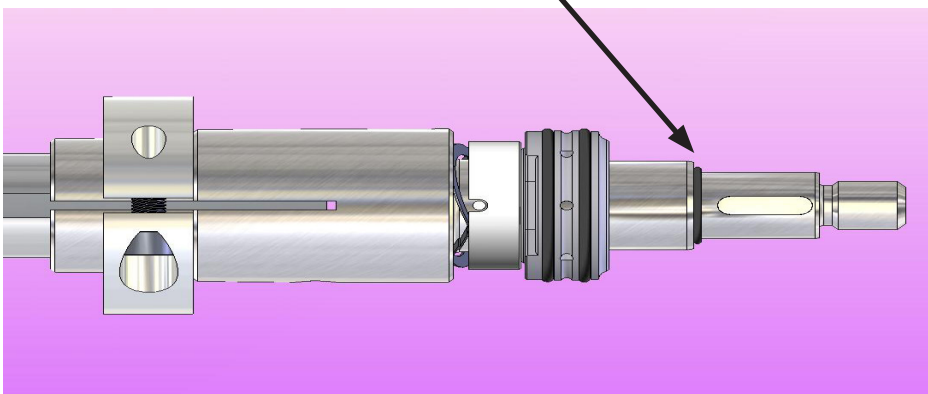

Figure 9

Slide inner seal driver O-ring onto the shaft and lubricate.

(Note: housing and flange removed from picture for clarity)

ROTATING SEAL - COIL SPRING STYLE ONLY

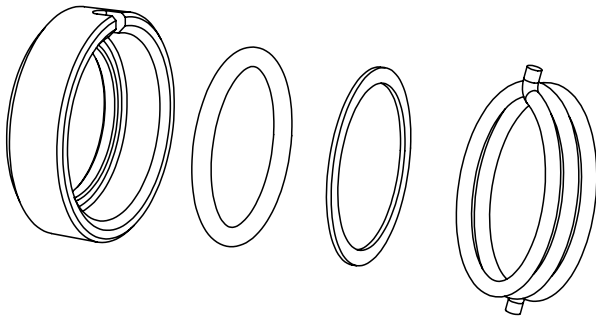

Figure 7C

Lubricate and place the seal o-ring inside the rotating seal.

Place the seal washer into the rotating seal.

Install one end of the seal spring into the rotating seal making sure that the tab of the spring is in the slot on the rotating seal.

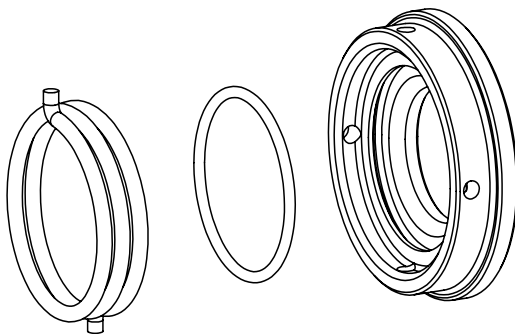
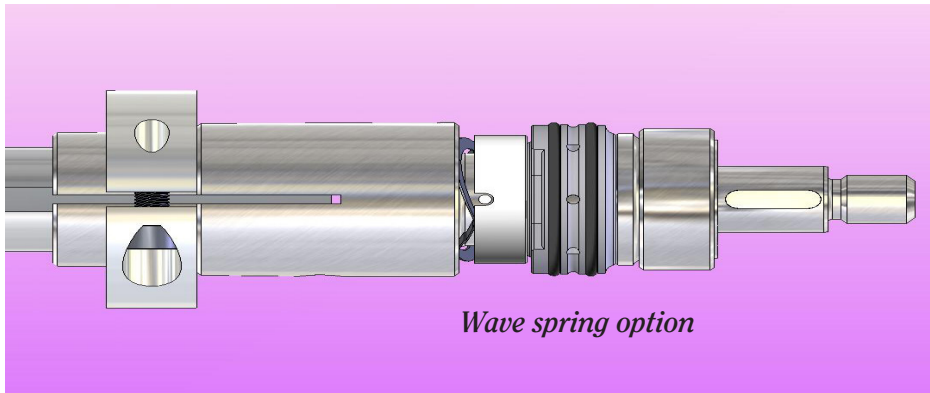

Figure 8C

Lubricate and place the inner seal driver o-ring inside the seal driver.

With one end of the spring already in the slot of the rotating seal, install the tab on the other end of the spring into the one of the holes on the front seal driver.



**PUMP ASSEMBLY,
CONTINUED**

Figure 10

Slide seal driver assembly onto the shaft.

(Note: housing and flange removed from picture for clarity)

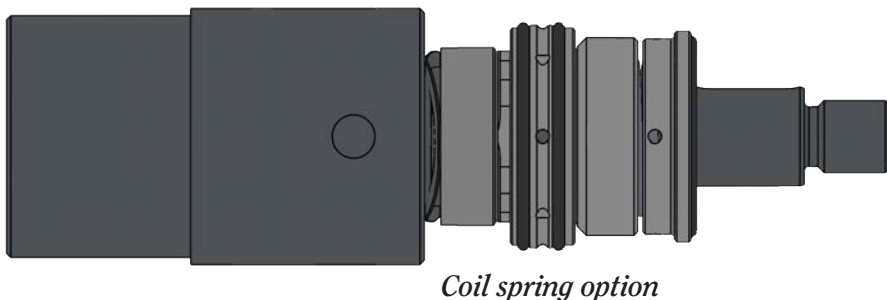



Figure 11

Install rotor key and outer seal driver O-ring. Lubricate O-ring.

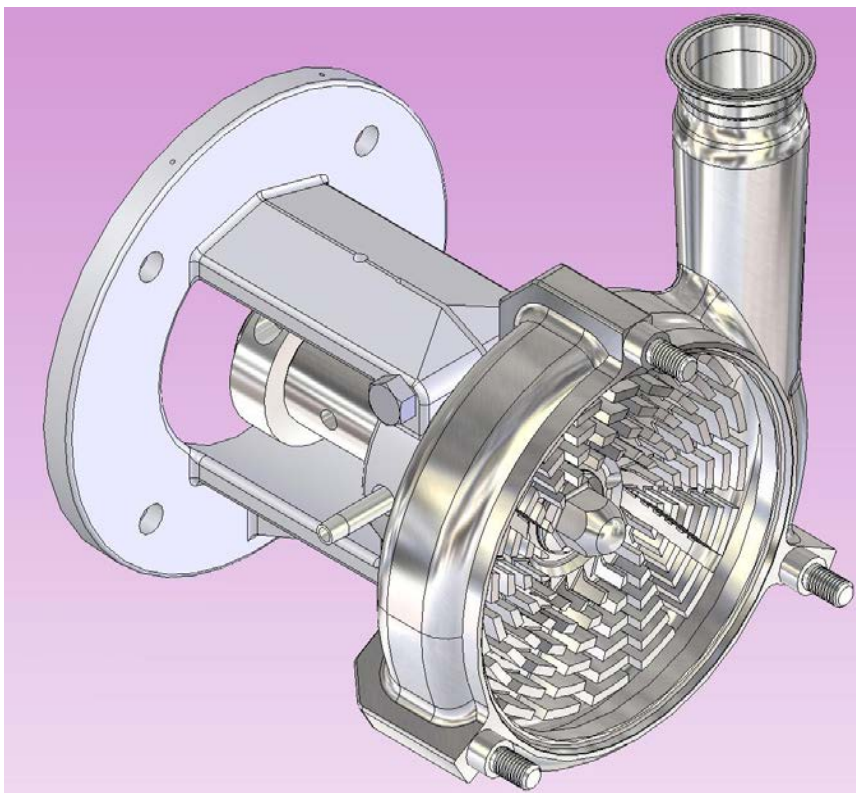

Figure 12

Slide rotor onto shaft making sure to align keyway in rotor with key in the shaft.

Lubricate rotor nut gasket and place it onto the rotor nut.

Thread rotor nut onto shaft. Place 3/8" rod or Phillips screwdriver in shaft hole to prevent it from turning. Use a torque wrench to tighten the rotor nut.

Figure 13

Install the inner and outer stator O-rings.

Install the stator onto the cover.

Tighten the stator nuts with a torque wrench.



Figure 14

Install cover O-ring.

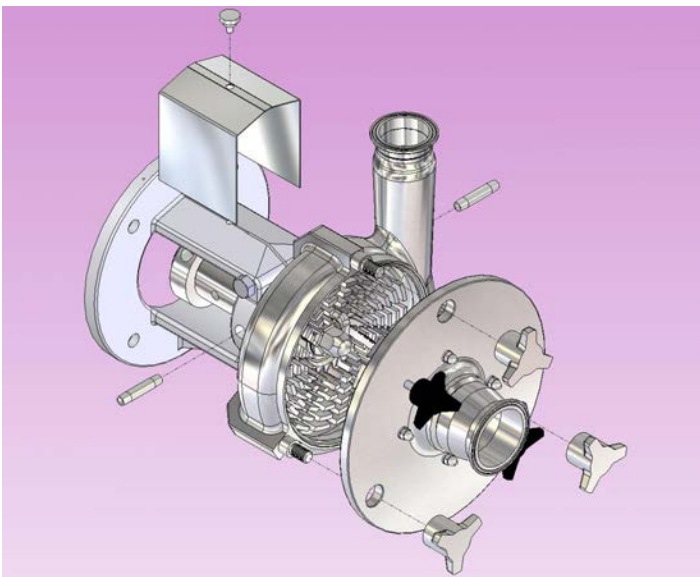
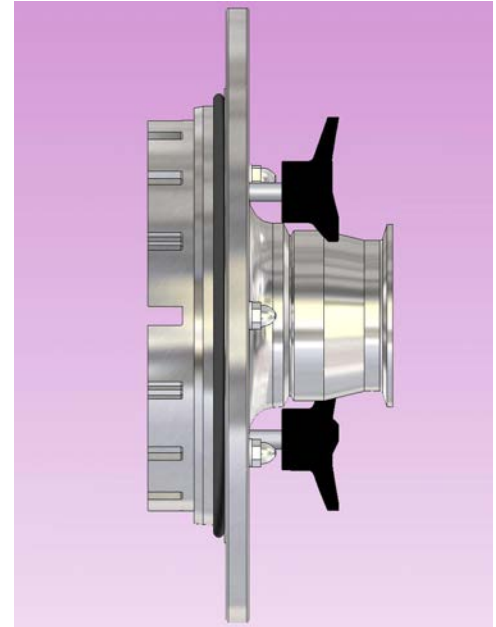

Figure 15

Install cover/stator assembly.

Install cover nuts and tighten.

Rotate the shaft to verify that the rotor turns freely.

Install the guard.

Install the water pipe(s) if necessary.

PUMP SHAFT REPLACEMENT

DISASSEMBLY

Disassemble pump as described in Figures 1-3

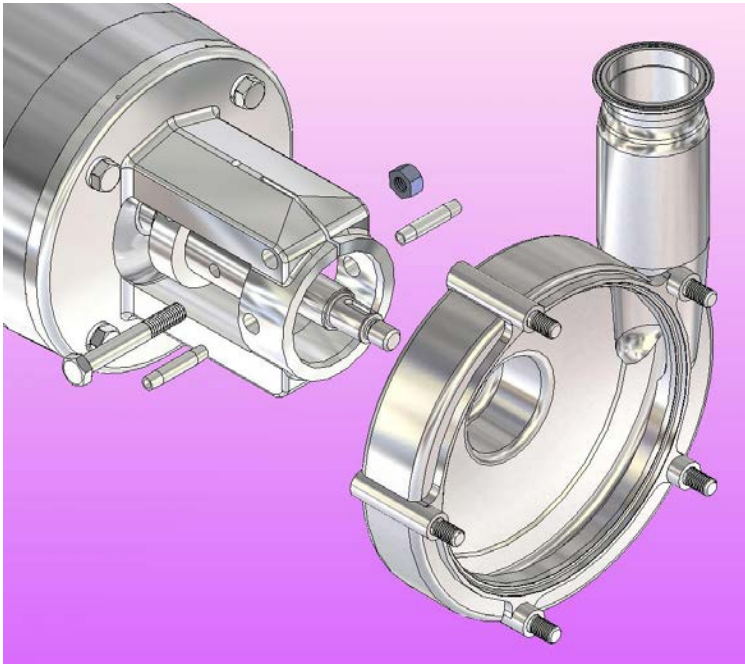

Figure 16a (single flange only)

Double Seal and Water Cascade Only:
Remove the water pipe(s).

Loosen the clamping bolt and nut. Remove the housing.



Figure 16b (double flange only)

Double Seal and Water Cascade Only: Remove the water pipe(s).

Remove the housing bolts and washers. Remove the housing.

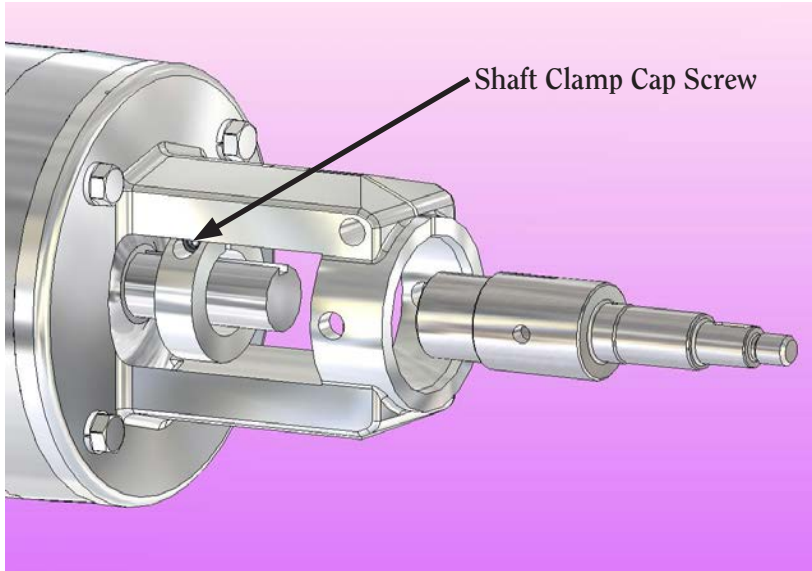
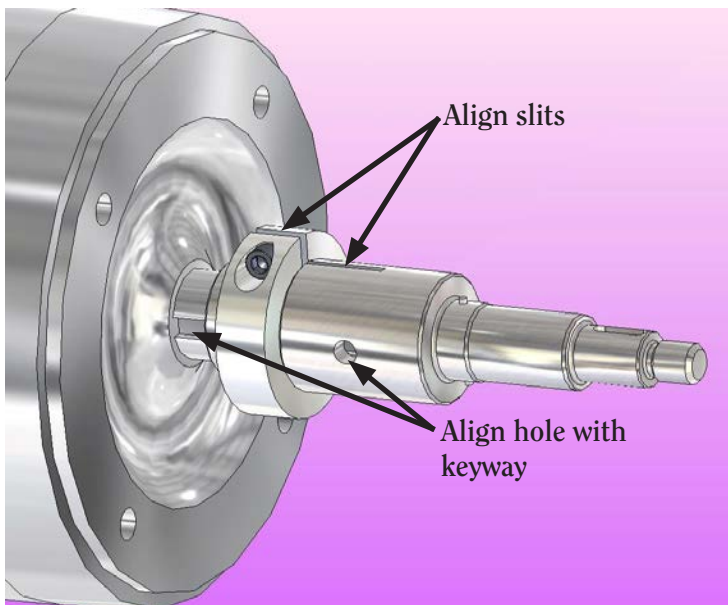

Figure 17

Use an Allen wrench to loosen the shaft clamp cap screw(s). Remove pump shaft.



ASSEMBLY

Figure 18

Install new shaft making sure to align the slit in the shaft with the slit in the shaft clamp. Also align the keyway in the motor shaft with the hole in the pump shaft.

Do not tighten the shaft clamp yet.

(Note: flange removed for clarity)

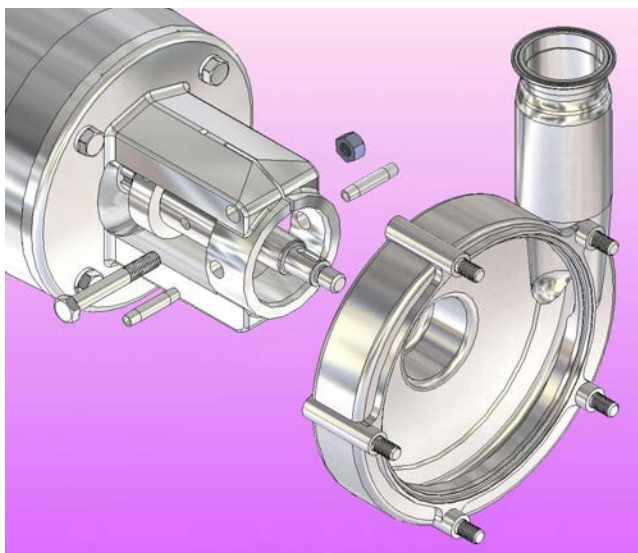

Figure 19a (single flange only)

Install housing hub into the flange. Rotate the inlet to align it with the piping.

Double Seal and Water Cascade Only: Install the water pipe(s).

Use a 3/4" wrench and a 3/4" torque wrench to torque the clamping bolt.

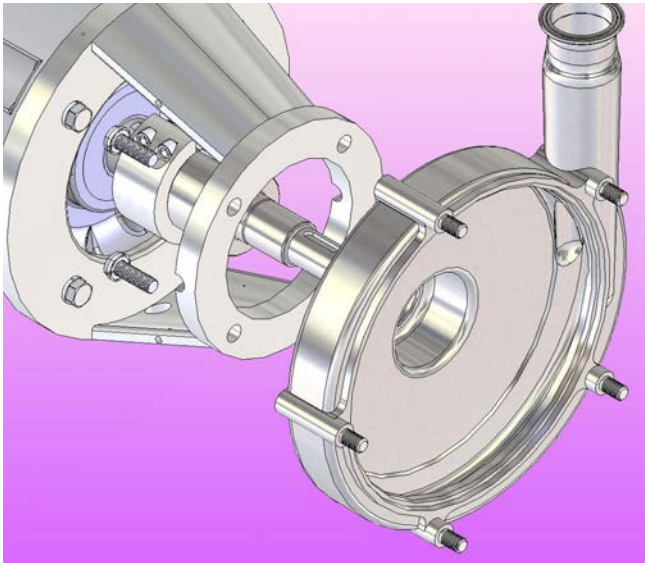

Figure 19b (double flange only)

Install housing hub into the flange. Rotate the inlet to align it with the piping and align bolt holes.

Double Seal and Water Cascade Only: Install the water pipe(s).

Install the lockwashers and bolts. Use a 3/4" torque wrench to torque the bolts.

SETTING ROTOR-TO-STATOR GAP

If you have removed the pump shaft from the motor shaft for any reason (such as replacing the shaft or motor), you must re-set the gap. Assemble the blender as described in Figures 4-12.



Figure 20

Place a 0.5mm gapping shim in between the stator and cover and install the stator lockwashers and nuts. The o-rings do not need to be installed on the stator.

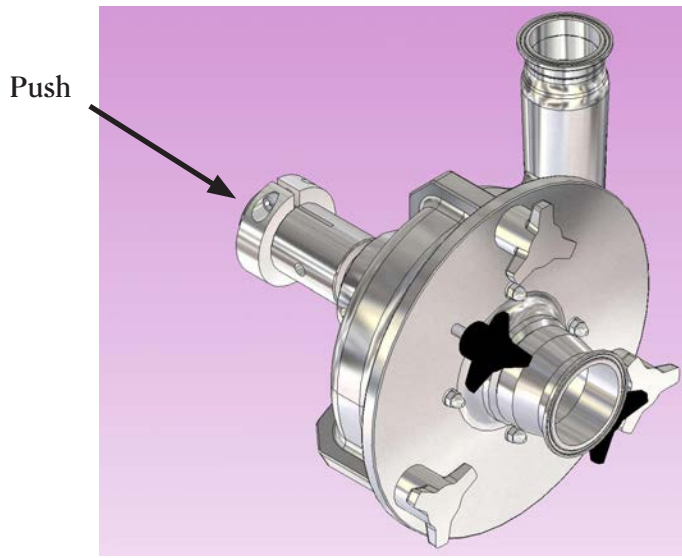

Figure 21

Install the seal driver. (It is not necessary to install the individual seal components to set the gap.)

Install the cover/stator assembly onto the housing.

Install the cover nuts and tighten.

Push the shaft forward until the rotor contacts the stator.

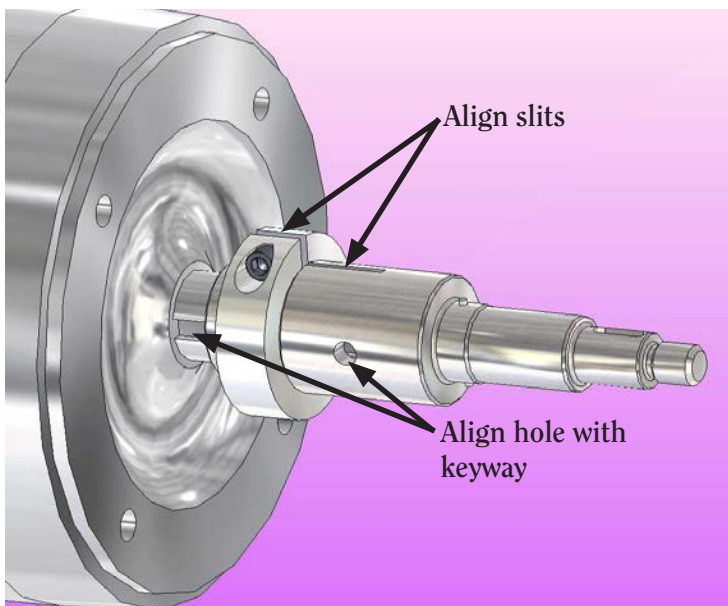

Figure 22

Make sure to align the slot in the shaft with the slot in the shaft clamp. Also align the keyway in the motor shaft with the hole in the blender shaft.

Tighten the shaft clamp bolt with a torque wrench.

Remove the cover and disassemble the stator.

Remove the gapping shim.

SETTING THE SHAFT ALIGNMENT

If you have removed the pump shaft from the motor shaft for any reason (such as replacing the shaft or motor), you must check the shaft alignment.

Figure 23

Remove the rotor, as described in Figure 2.

Remove the housing, as described in Figure 16.

Using a dial indicator or similar device, measure the shaft alignment. The TIR (Total Indicated Run-out) of the shaft must be within .05mm (.002in).

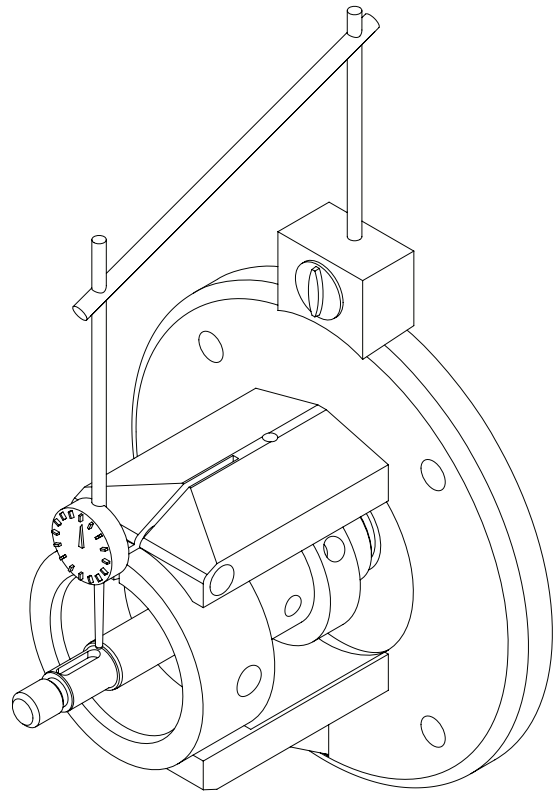

126500082
12/10/02

Figure 24

To adjust run-out, tap the end of the shaft at its high point with a soft-faced hammer until it is within the tolerance.

Re-check the shaft collar torque.

Re-install the housing.

Continue the installation process as described in Figures 12-15.

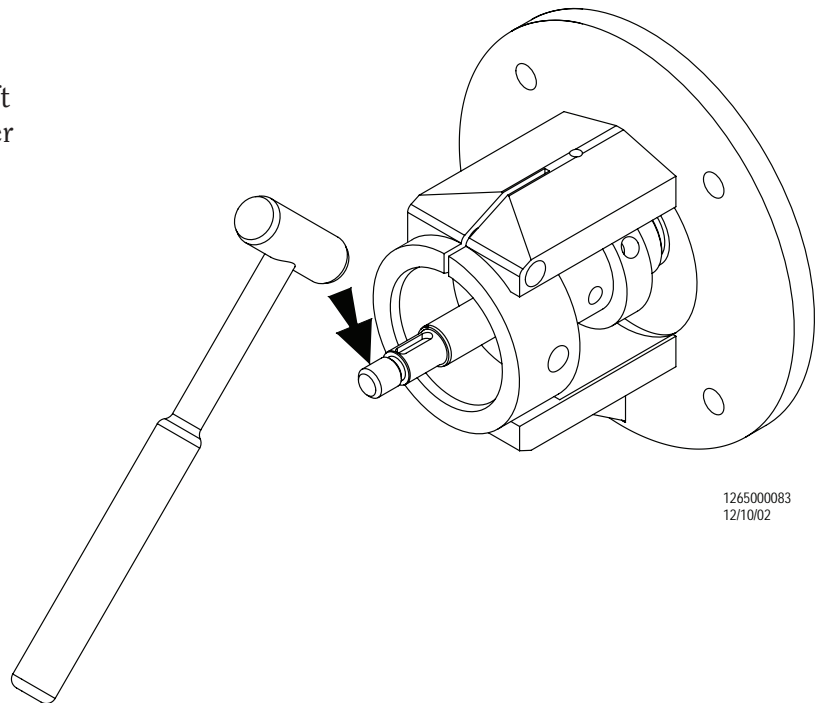

126500083
12/10/02

MOTOR REPLACEMENT

DISASSEMBLY

Disassemble pump as described in figures 1-3.

Remove housing and shaft as described in figures 15-17.

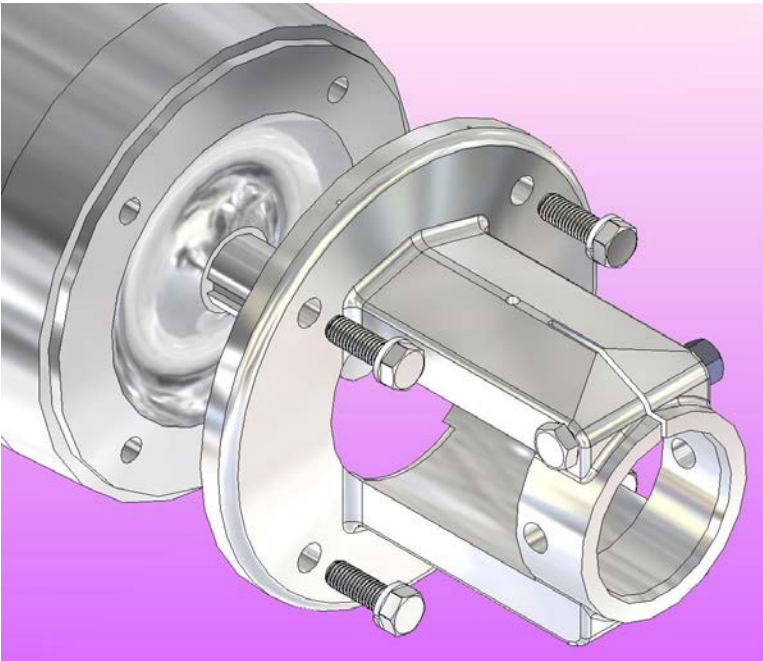

Figure 25

Use a socket to remove the motor bolts and washers. Remove the flange.

ASSEMBLY

Replace motor. Install flange onto motor. Replace bolts and washers. Use a torque wrench to tighten the bolts to the correct torque (see page 4 for torque values).

Install shaft and housing as described in figures 18-19.

Assemble seal as described in figures 4-11.

Set rotor-to-stator gap as described in figure 20-22.

Install cover O-ring, cover/stator assembly, and cover nuts as described in figures 13-15.

Replace guard(s) and water pipe(s) if necessary.

NOTICE OF TERMS, WARRANTY PROVISIONS INCLUDING DISCLAIMERS, CLAIMS AND LIMITATION OF LIABILITY

Prices and all terms and conditions of sale are established in current price sheets and are subject to change without notice. All orders are subject to acceptance by Fristam Pumps USA, Limited Partnership.

Each Fristam Pumps item is warranted to be free from manufacturing defects for a period of one (1) year from the date of shipment, providing it has been used as recommended and in accordance with recognized piping practice, and providing it has not been worn out due to severe service, such as encountered under extremely corrosive or abrasive conditions.

This warranty is expressly in lieu of any other warranties expressed or implied, including but not limited to, any implied warranty of merchantability or fitness for particular purpose. All other warranties whatsoever, expressed or implied by law or otherwise, are hereby excluded.

All claims must be in writing and must be mailed or delivered by purchaser within thirty (30) days after purchaser learns of the facts upon which such claim is based. Any claim not made in writing and within the time period specified above shall be deemed waived.

Purchaser's sole and exclusive remedy and Fristam Pumps maximum liability for claims arising hereunder or for negligence for any and all losses and damages resulting from any cause shall be either the repair or replacement of defective items or, at Fristam Pumps' option, the refund of the purchase price for such items. In no event, including in the case of a claim for negligence, shall Fristam Pumps be liable for incidental or consequential damages, including loss of profits.

No person, including any representative employee or agent of Fristam Pumps is authorized to assume on behalf of Fristam Pumps any liability or responsibility in addition to or different from that described in this provision. Any and all representations, promises, warranties or statements that are in addition to or different from the terms of this provision are of no force or effect.

If any provision of this Notice is held to be invalid, such provision shall be severed and the remaining provisions shall continue to be in force.



© 2024 - Fristam Pumps USA
Drawing # 1250000022 Updated 6/5/24
Part # 1050000216
Visit www.fristam.com/usa for a current list of literature.

2410 Parview Road • Middleton, WI 53562-2524
1-800-841-5001 • 608-831-5001
Website: www.fristam.com/usa
Email: fristam@fristampumps.com